

YOKE®

8-2018A

Safety is our first priority™



Type Approved By:

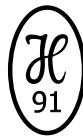

General Catalog No. 8-2018A

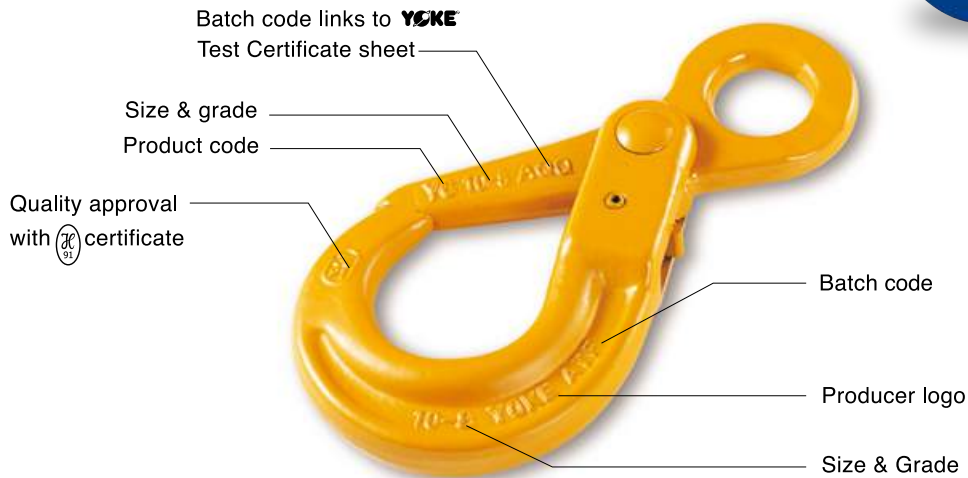
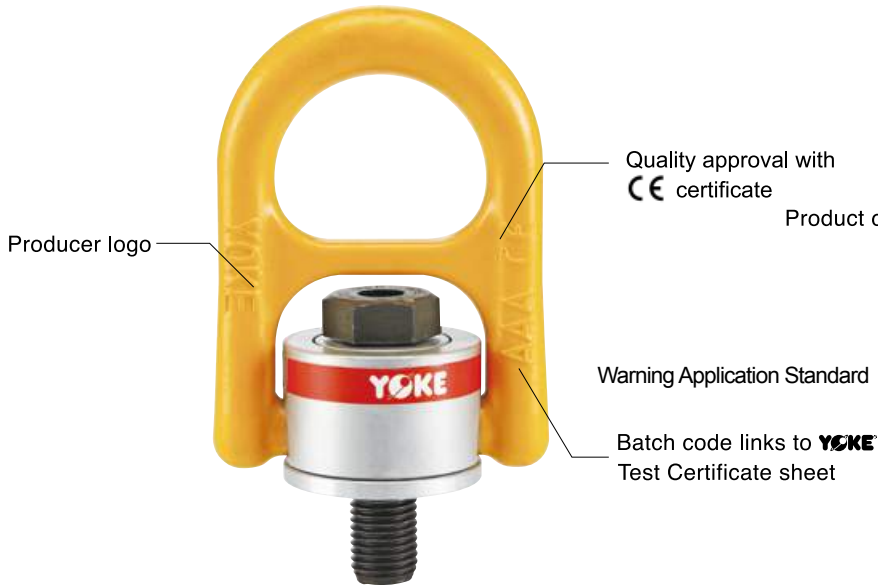
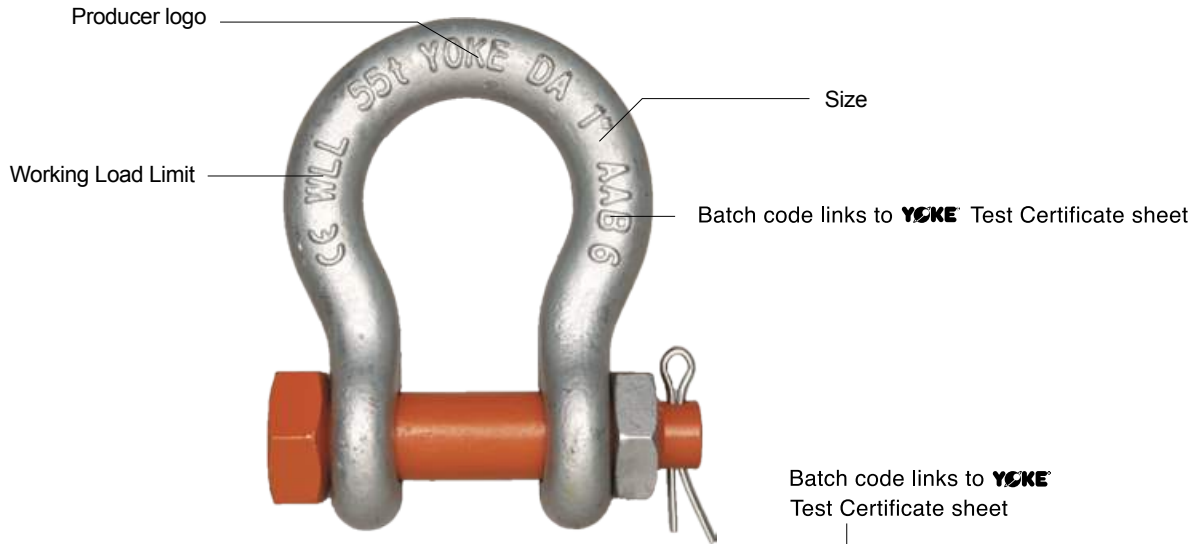

Worldwide Quality Type Approval And Certificate:



<http://www.yoke.net/thirdpartycertificate>



Quality Control, Testing, and Detecting during manufacturing

YOKE runs a constant and strict production facility with quality control in every manufacturing stage from raw materials to the completed product. YOKE is an ISO 9001 certified company and has Type Approval by the major international authorities from SABS, ZU, ABS, API, and DNV. YOKE has achieved CNLA certification - Chinese National Laboratory Accreditation which ensures a quality research and development (R&D) department and unsurpassed product engineering.

■ Magnaflux Crack Detection:

All forged components, each individually magnaflux detected after heat treatment.

■ Proof Load Testing:

Chain and components are proof load tested at 2.5 times the Working Load Limits with resultant permanent deformation within 1%.

■ Dynamic Fatigue Testing:

Batch samples of chain and components are Dynamic Fatigue Tested at 1.5 times Working Load Limit for 20,000 cycles.

■ Ultimate Breaking Load Testing:

Batch samples are Break Load Tested in a static tensile testing machine to ultimate failure. The minimum ultimate force is equal to the Working Load Limit times the safety factor.

■ Spectrographic Analysis:

To assure of the proper metallurgy content of all raw materials.

■ Eddy Current Detection:

All load pins are 100% individually inspected after heat treatment.



Test certificate



YOKE

YOKE[®]
Safety is our first priority[™]

Safety is our first priority TM

- Quality, Reliability, Innovation -

P.8
Yellow Point



P.72
Grade 100 Lifting
Chain Fittings



P.123
Grade 80 Lifting
Chain Fittings



P.157
DA Series



P.179
ROV
Hooks, Shackles



P.183
Snatch Blocks
Hay Fork Pulleys
Trawl & Blocks



P.212
Wire Rope Socket
&
Sleeves



P.224
Shackle
Turnbuckle
Wire Rope Clip



P.244
Angular Contact
Bearing Swivels



P.252
Hoist Hooks



P.262
RFFTM RingForged-FabricatedTM
Heavy Duty Oilfield Sheaves





Yellow Point

A total solution product for complex lifting,
turning, rotating and tilting.







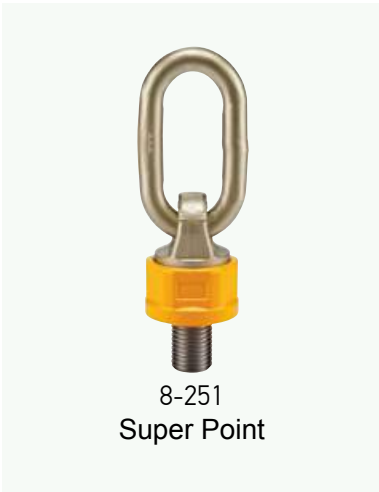

YOKE YP Size & WLL Chart



	8-211	8-231	8-241	8-203	8-251	8-271	8-2511	8-291	8-S291
Thread	WLL(t)								
M 8	0.3	0.5	0.5	0.5		0.4		0.3	
M10	0.63	0.7	0.7	0.55	0.5	0.6		0.4	
M12	1	1	1	1.3	0.7	0.7		0.75	0.5
M14	1.2	1.5			1				
M16	1.5	2	2	2.4	1.4	1.5	1.4	1.5	1
M18	2	2.5							
M20				2.7	1.7				
	2.5	3	3	3.75	2.5	2.5	2.5	2.3	2
M24					1.7				
	4	5	5	5.25	4	4	4	3.2	2.5
M27	4	5.6	5.6						
M30					4				
					6.7				
	5	7.8	7.8	8.75	8	7.5	6.7	4.5	
M36	7								
	8	12.5	12.5	13.75	10	10	10	7	
M42	10				12.5				
	15	15.6	15.6	15.6	13	13	13	9	
M45					12.5				
					17				
M48					12.5				
	20	20	20	16.9	17	14	16	12	
M56		22	22	19.4	18	20		12	
M64					20				
		22.5	22.5	27.9	28	20		12	
M72					28				
M80					28				
					35				
					40				
M90					35				
					40				
M100					40				

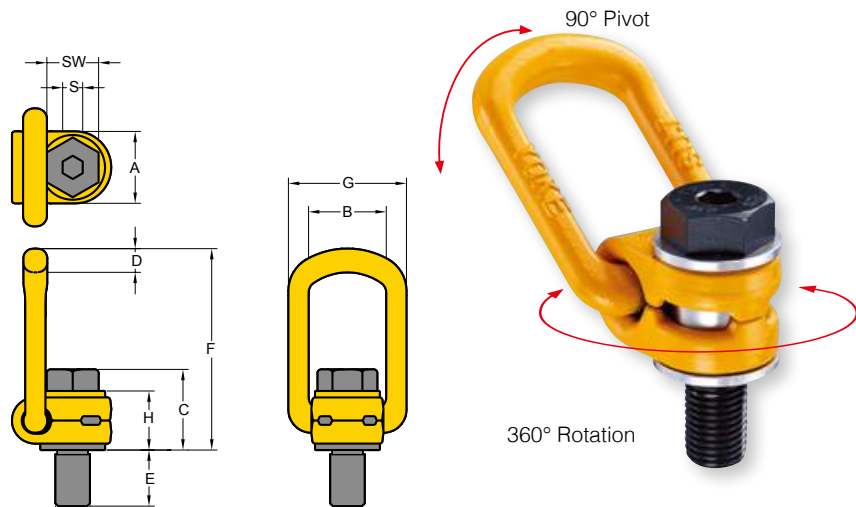

» Taiwan Patent
» China Patent

- Rotates through 360° and pivot 90°.
- Manufactured from alloy steel, quenched and tempered.
- Manufactured and tested in accordance with EN1677-1.
- Load rated parts are 100% magnaflux crack detected.
- Individual forged parts and cap screw are traceable to Test Certification.
- Bolts are Metric thread (ASME / ANSI B18.3.1M)
- Individually proof tested to 2.5 times the WLL.
- Fatigue rated to 1.5 times the WLL.
- All YOKE Lifting points meet or exceed all the requirements of ASME B30.26.
- Quick and simple assembly, just a tapped hole is required.

Lifting Point

Metric Thread (8-211)



Item No.	Working Load Limit tonnes	Thread version			Dimensions									Torque in		N.W. kg
		M	E	Pitch DIN13	A	B	C	D	F	G	H	S	SW	Nm		
8-211-003	0.3	M 8	11	1.25	30	35	35	10	85	55	29	6	13	30	0.2	
8-211-006	0.63	M 10	16	1.5	30	35	36	10	85	55	29	6	17	60	0.3	
8-211-010	1	M 12	18	1.75	33	37	44	14	98	57	36	8	19	100	0.5	
8-211-012	1.2	M 14	21	2	33	37	45	14	98	57	36	10	22	120	0.5	
8-211-015	1.5	M 16	24	2	33	37	46	14	98	57	36	10	24	150	0.5	
8-211-020	2	M 18	26	2	50	54	57	17	140	82	44	12	30	200	1.3	
8-211-025	2.5	M 20	30	2.5	50	54	57	17	140	82	44	12	30	250	1.3	
8-211-040	4	M 24	36	3	50	54	59	17	140	82	44	14	36	400	1.4	
8-211-042	4	M 27	38	3	60	65	79	23	170	99	62	17	41	400	2.8	
8-211-050	5	M 30	48	3.5	60	65	81	23	170	99	62	17	46	500	3.1	
8-211-070	7	M 36	54	4	60	65	88	23	178	99	65	22	55	700	3.3	
8-211-080	8	M 36	62	4	77	85	101	27	225	124	78	22	55	800	5.8	
8-211-100	10	M 42	72	4.5	77	85	104	27	225	124	78	24	65	1000	6.3	
8-211-150	15	M 42	63	4.5	95	104	112	36	256	158	86	24	65	1500	10.8	
8-211-200	20	M 48	72	5	95	104	120	36	259	158	90	27	75	2000	11.6	

* Design Factor 4:1

* Bolt in GEOMET® finished on request



Kind of attachment

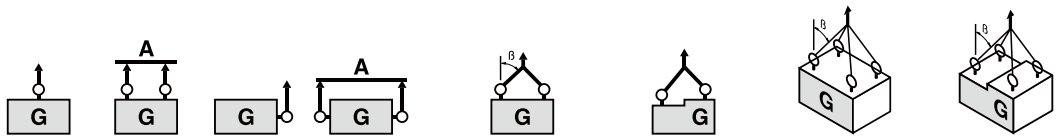

Item No.	Thread	WLL(t)										
		1	2	1	2	2	2	2	3-4	3-4	3-4	
8-211-003	M 8	0.3	0.6	0.3	0.6	0.42	0.3	0.3	0.63	0.45	0.3	
8-211-006	M 10	0.63	1.26	0.63	1.26	0.88	0.63	0.63	1.32	0.95	0.63	
8-211-010	M 12	1	2	1	2	1.4	1	1	2.1	1.5	1	
8-211-012	M 14	1.2	2.4	1.2	2.4	1.7	1.2	1.2	2.5	1.8	1.2	
8-211-015	M 16	1.5	3	1.5	3	2.1	1.5	1.5	3.1	2.2	1.5	
8-211-020	M 18	2	4	2	4	2.8	2	2	4.2	3	2	
8-211-025	M 20	2.5	5	2.5	5	3.5	2.5	2.5	5.2	3.7	2.5	
8-211-040	M 24	4	8	4	8	5.6	4	4	8.4	6	4	
8-211-042	M 27	4	8	4	8	5.6	4	4	8.4	6	4	
8-211-050	M 30	5	10	5	10	7	5	5	10.5	7.5	5	
8-211-070	M 36	7	14	7	14	9.8	7	7	14.7	10.5	7	
8-211-080	M 36	8	16	8	16	11.2	8	8	16.8	12	8	
8-211-100	M 42	10	20	10	20	14	10	10	21	15	10	
8-211-150	M 42	15	30	15	30	21	15	15	31.5	22.5	15	
8-211-200	M 48	20	40	20	40	28	20	20	42	30	20	

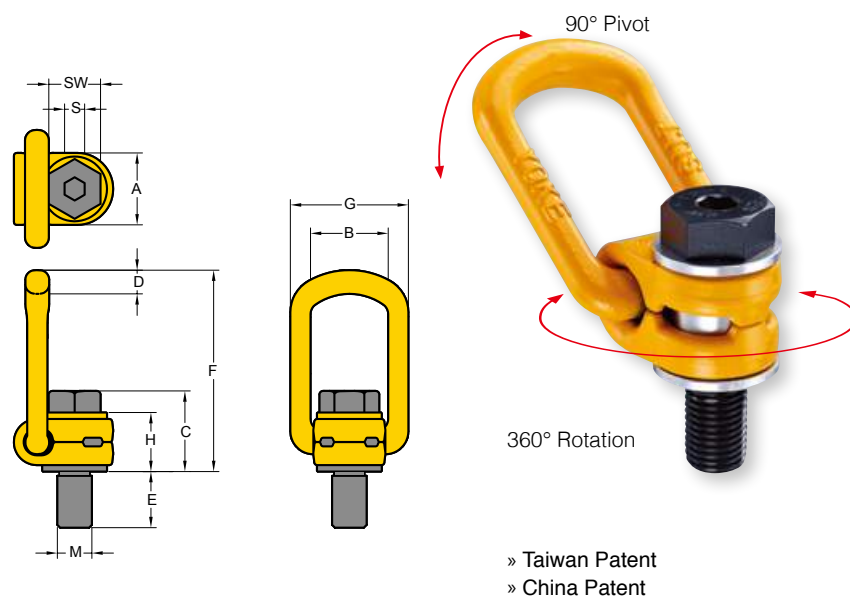

- Rotates through 360° and pivot 90°.
- Manufactured from alloy steel, quenched and tempered.
- Manufactured and tested in accordance with EN1677-1.
- Load rated parts are 100% magnaflux crack detected.
- Individual forged parts and cap screw are traceable to Test Certification.
- Bolts are UNC thread (ASME / ANSI B18.3.1M)
- Individually proof tested to 2.5 times the WLL.
- Fatigue rated to 1.5 times the WLL.
- All YOKE Lifting points meet or exceed all the requirements of ASME B30.26.
- Quick and simple assembly, just a tapped hole is required.

Lifting Point

UNC Thread (8-212)



Item No.	Working Load Limit tonnes	Thread version			Dimensions										Torque		N.W. lbs
		M inch	E inch	TPI	A	B	C	D	F	G	H	S	SW	Nm			
8-212-010	1	1/2	0.75	13UNC	1.30	1.46	1.73	0.53	3.86	2.24	1.42	5/16	3/4	100	1.1		
8-212-015	1.5	5/8	0.94	11UNC	1.30	1.46	1.81	0.53	3.86	2.24	1.42	3/8	15/16	150	1.1		
8-212-020	2.5	3/4	1.10	10UNC	1.97	2.13	2.20	0.65	5.51	3.23	1.73	1/2	1 1/8	250	2.9		
8-212-025	2.5	7/8	1.10	9UNC	1.97	2.13	2.28	0.65	5.51	3.23	1.73	5/8	1 5/16	300	2.9		
8-212-040	4	1	1.61	8UNC	1.97	2.13	2.34	0.65	5.51	3.23	1.73	5/8	1 1/2	400	3.1		
8-212-050	5	1 1/4	1.61	7UNC	2.36	2.56	3.23	0.89	6.69	3.90	2.44	7/8	1 7/8	500	6.8		
8-212-080	8	1 1/2	2.25	6UNC	3.03	3.35	4.01	1.04	8.86	4.88	3.07	1	2 1/4	800	12.8		
8-212-150	15	1 3/4	2.63	5UNC	3.74	4.09	4.48	1.42	10.08	6.22	3.39	1	2 5/8	1500	24.0		
8-212-200	20	2	3.00	4.5UNC	3.74	4.09	4.76	1.42	10.20	6.22	3.54	1 1/4	3	2000	25.5		

* Design Factor 4:1

* Bolt in GEOMET® finished on request



Kind of attachment											
	Number of legs	1	2	1	2	2	2	2	3-4	3-4	3-4
Load direction	0°	0°	90°	90°	0-45°	45°- 60°	unsymm.	0 - 45°	45°- 60°	unsymm.	
Item No.	Thread	WLL(t)									
8-212-010	1/2	1	2	1	2	1.4	1	1	2.1	1.5	1
8-212-015	5/8	1.5	3	1.5	3	2.1	1.5	1.5	3.1	2.2	1.5
8-212-020	3/4	2.5	5	2.5	5	3.5	2.5	2.5	5.2	3.7	2.5
8-212-025	7/8	2.5	5	2.5	5	3.5	2.5	2.5	5.2	3.7	2.5
8-212-040	1	4	8	4	8	5.6	4	4	8.4	6	4
8-212-050	1 1/4	5	10	5	10	7	5	5	10.5	7.5	5
8-212-080	1 1/2	8	16	8	16	11.2	8	8	16.8	12	8
8-212-150	1 3/4	15	30	15	30	21	15	15	31.5	22.5	15
8-212-200	2	20	40	20	40	28	20	20	42	30	20

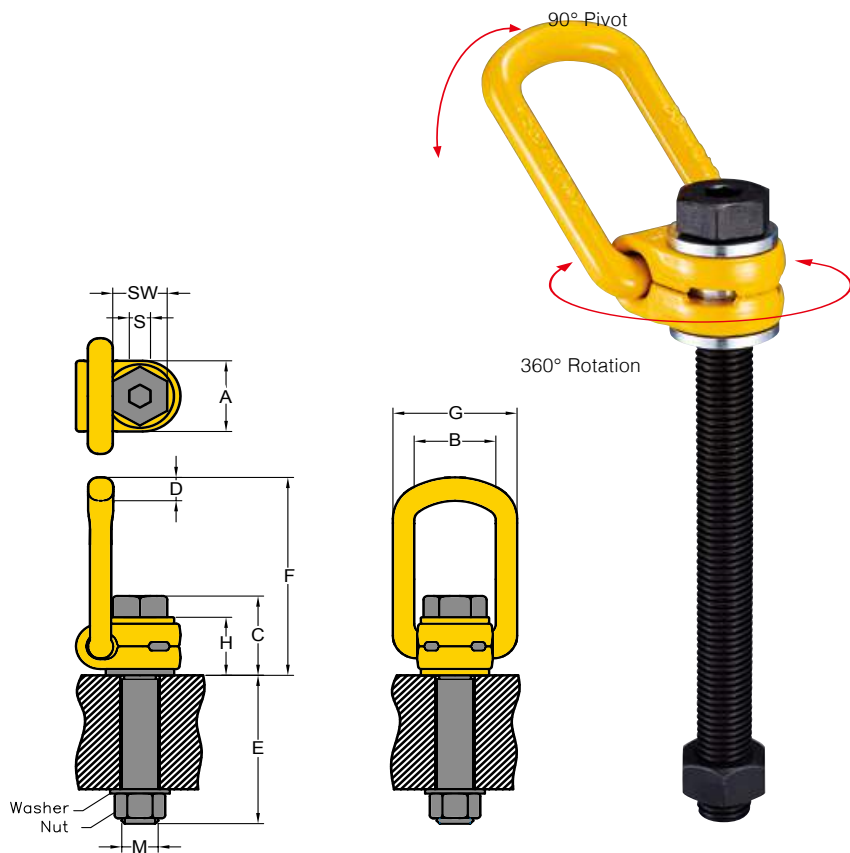

- Rotates through 360° and pivot 90°.
- Manufactured from alloy steel, quenched and tempered.
- Manufactured and tested in accordance with EN1677-1.
- Load rated parts are 100% magnaflux crack detected.
- Individual forged parts and cap screw are traceable to Test Certification.
- Bolts are Metric thread (ASME / ANSI B18.3.1M)
- Individually proof tested to 2.5 times the WLL.
- Fatigue rated to 1.5 times the WLL.
- All YOKE Lifting points meet or exceed all the requirements of ASME B30.26.
- Quick and simple assembly, just a tapped hole is required.

» Taiwan Patent
» China Patent

Lifting Point Long Bolt

Metric Thread (8-211)



Item No.	Working Load Limit tonnes	Thread version			Dimensions									Torque in		N.W. kg
		M	E	Pitch DIN13	A	B	C	D	F	G	H	S	SW	Nm		
8-211-003/105L	0.3	M 8	76	1.25	30	35	35	10	85	55	29	6	13	30	0.3	
8-211-006/125L	0.63	M 10	96	1.5	30	35	36	10	85	55	29	6	17	60	0.4	
8-211-010/150L	1	M 12	114	1.75	33	37	44	14	98	57	36	8	19	100	0.6	
8-211-015/185L	1.5	M 16	149	2	33	37	46	14	98	57	36	10	24	150	0.7	
8-211-025/230L	2.5	M 20	186	2.5	50	54	57	17	140	82	44	12	30	250	1.7	
8-211-040/265L	4	M 24	221	3	50	54	59	17	140	82	44	14	36	400	2.1	
8-211-050/340L	5	M 30	278	3.5	60	65	81	23	170	99	62	17	46	500	4.3	
8-211-080/300L	8	M 36	222	4	77	85	101	27	225	124	78	22	55	800	7.3	
8-211-100/350L	10	M 42	272	4.5	77	85	104	27	225	124	78	24	65	1000	8.7	
8-211-150/350L	15	M 42	264	4.5	95	104	112	36	256	158	86	24	65	1500	13.1	
8-211-200/385L	20	M 48	295	5	95	104	120	36	259	158	90	27	75	2000	15.2	

* Design Factor 4:1

* Bolt in GEOMET® finished on request



Kind of attachment

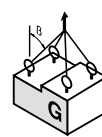
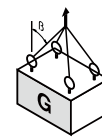
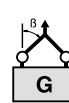
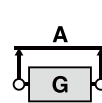
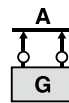
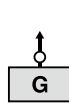

Number of legs	Load direction	WLL(t)										
		1	2	1	2	2	2	2	3-4	3-4	3-4	
Item No.	Thread	0°	0°	90°	90°	0-45°	45°-60°	unsymm.	0-45°	45°-60°	unsymm.	
8-211-003/105L	M 8	0.3	0.6	0.3	0.6	0.42	0.3	0.3	0.63	0.45	0.3	
8-211-006/125L	M10	0.63	1.26	0.63	1.26	0.88	0.63	0.63	1.32	0.95	0.63	
8-211-010/150L	M12	1	2	1	2	1.4	1	1	2.1	1.5	1	
8-211-015/185L	M16	1.5	3	1.5	3	2.1	1.5	1.5	3.1	2.2	1.5	
8-211-025/230L	M20	2.5	5	2.5	5	3.5	2.5	2.5	5.2	3.7	2.5	
8-211-040/265L	M24	4	8	4	8	5.6	4	4	8.4	6	4	
8-211-050/340L	M30	5	10	5	10	7	5	5	10.5	7.5	5	
8-211-080/300L	M36	8	16	8	16	11.2	8	8	16.8	12	8	
8-211-100/350L	M42	10	20	10	20	14	10	10	21	15	10	
8-211-150/350L	M42	15	30	15	30	21	15	15	31.5	22.5	15	
8-211-200/385L	M48	20	40	20	40	28	20	20	42	30	20	

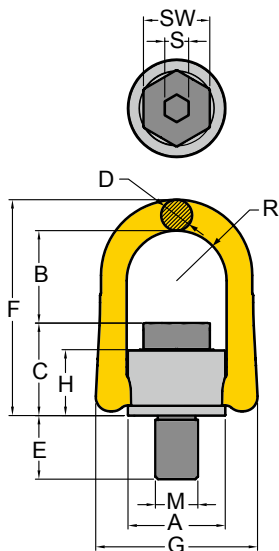

360° Rotation
 » Taiwan Patent
 » China Patent

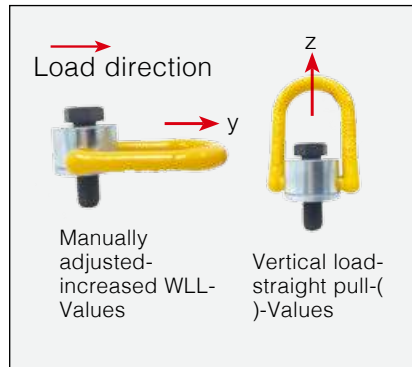

- Rotates through 360° and pivot 180°, and simultaneously allows lifting from any direction.
- Manufactured from forged alloy steel, quenched and tempered.
- Manufactured and tested in accordance with EN1677-1.
- Load rated parts are 100% magnaflux crack detected.
- Individual forged parts and cap screw are traceable to Test Certification.
- Bolt are Metric thread (ASME / ANSI B18.3.1M).
- Proof tested to 2.5 times the WLL.
- Fatigue rated to 1.5 times the WLL.
- All YOKE Lifting points meet or exceed all the requirements of ASME B30.26.
- Quick and simple assembly, just a tapped hole is required.

Anchor Point

Metric Thread (8-231)



Item No.	Working Load Limit		Thread version			Dimensions										Torque	N.W.
	y	(z)	M	E	Pitch	A	B	C	D	F	G	H	R	S	SW	in	kg
	tonnes		mm	mm	DIN13				mm							Nm	
8-231-005	0.5	0.8	M 8	12	1.25	33	42	28	11	80	58	23	17	6	13	30	0.3
8-231-007	0.7	1.2	M 10	15	1.5	33	41	29	11	80	58	23	17	6	17	60	0.3
8-231-010	1.0	2.0	M 12	20	1.75	33	40	31	11	80	58	23	17	8	19	100	0.3
8-231-015	1.5	2.4	M 14	21	2	50	56	45	17	117	90	36	27	10	22	120	0.9
8-231-020	2.0	3.2	M 16	24	2	50	54	46	17	117	90	36	27	10	24	150	0.9
8-231-025	2.5	5.0	M 18	26	2.5	65	78	57	20	153	108	44	34	12	30	200	1.9
8-231-030	3.0	5.6	M 20	30	2.5	50	52	49	17	117	90	36	27	12	30	250	1.0
8-231-050	5.0	9.2	M 24	36	3	72	81	59	25	163	125	44	37	14	36	400	2.6
8-231-056	5.6	9.2	M 27	38	3	87	86	79	30	204	148	62	46	17	41	400	4.9
8-231-078	7.8	12.0	M 30	48	3.5	87	94	81	30	204	148	62	46	17	46	500	5.0
8-231-125	12.5	14.0	M 36	54	4	110	112	98	36	247	188	75	57	22	55	1000	9.6
8-231-156	15.6	16.0	M 42	63	4.5	110	101	108	36	247	188	83	57	24	65	1500	10.9
8-231-200	20.0	20.0	M 48	72	5	110	97	113	36	248	188	83	57	27	75	2000	11.6
8-231-220	22.0	22.0	M 56	84	5.5	123	116	121	36	274	202	91	64	27	85	2100	15.0
8-231-225	22.5	22.5	M 64	100	6	123	111	126	36	274	202	91	64	32	95	2200	16.3

* Proof Load is 2.5 times the Working Load Limit on the 4:1 design factor.

* Bolt in GEOMET™ finished on request



Kind of attachment											
Number of legs	Load direction	1	2	1	2	2	2	2	3-4	3-4	3-4
Item No.	Thread	0°	0°	90°	90°	0-45°	45°- 60°	unsymm.	0 - 45°	45°- 60°	unsymm.
		WLL(t)									
8-231-005	M 8	0.8	1.6	0.5	1	0.7	0.5	0.5	1.1	0.8	0.5
8-231-007	M10	1.2	2.4	0.7	1.4	1	0.7	0.7	1.5	1.1	0.7
8-231-010	M12	2	4	1	2	1.4	1	1	2.1	1.5	1
8-231-015	M14	2.4	4.8	1.5	3	2.1	1.5	1.5	3.2	2.3	1.5
8-231-020	M16	3.2	6.4	2	4	2.8	2	2	4.2	3	2
8-231-025	M18	5	10	2.5	5	3.5	2.5	2.5	5.3	3.8	2.5
8-231-030	M20	5.6	11.2	3	6	4.2	3	3	6.3	4.5	3
8-231-050	M24	9.2	18.4	5	10	7	5	5	10.5	7.5	5
8-231-056	M27	10	20	5.6	11.2	7.8	5.6	5.6	11.8	8.4	5.6
8-231-078	M30	12	24	7.8	15.6	10.9	7.8	7.8	16.4	11.7	7.8
8-231-125	M36	14	28	12.5	25	17.5	12.5	12.5	26.3	18.8	12.5
8-231-156	M42	16	32	15.6	31.2	21.8	15.6	15.6	32.8	23.4	15.6
8-231-200	M48	20	40	20	40	28	20	20	42	30	20
8-231-220	M56	22	44	22	44	30.8	22	22	46.2	33	22
8-231-225	M64	22.5	45	22.5	40	28	20	20	42	30	20

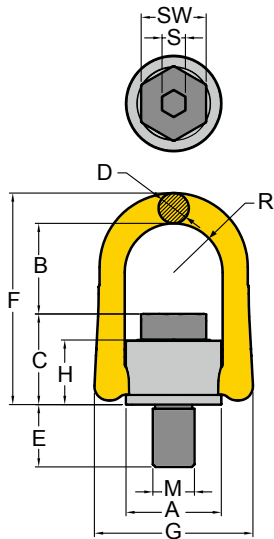

» Taiwan Patent
» China Patent

- Rotates through 360° and pivot 180°, and simultaneously allows lifting from any direction.
- Manufactured from forged alloy steel, quenched and tempered.
- Manufactured and tested in accordance with EN1677-1.
- Load rated parts are 100% magnaflux crack detected.
- Individual forged parts and cap screw are traceable to Test Certification.
- Bolt are Metric thread (ASME / ANSI B18.3.1M).
- Proof tested to 2.5 times the WLL.
- Fatigue rated to 1.5 times the WLL.
- All YOKE Lifting points meet or exceed all the requirements of ASME B30.26.
- Quick and simple assembly, just a tapped hole is required.

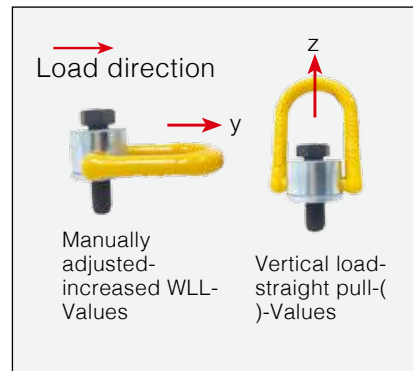

Anchor Point

UNC Thread (8-232)



Item No.	Working Load Limit		Thread version			Dimensions										Torque	
	y	(z)	M	E	TPI	A	B	C	D	F	G	H	R	S	SW	in	N.W.
	tonnes		inch	inch					inch							Nm	lbs
8-232-010	0.8	1.6	1/2	0.81	13 UNC	1.3	1.57	1.20	0.41	3.17	2.28	0.90	0.67	5/16	3/4	100	1.8
8-232-020	1.6	2.6	5/8	1.13	11 UNC	1.97	2.13	1.81	0.65	4.61	3.54	1.42	1.06	3/8	15/16	150	2.0
8-232-030	2.4	4.0	3/4	1.54	10 UNC	1.97	2.07	1.89	0.65	4.61	3.54	1.42	1.06	1/2	1 1/8	250	2.2
8-232-038	3.0	4.5	7/8	1.42	9 UNC	2.56	2.99	2.28	0.79	6.02	4.25	1.73	1.34	5/8	1 5/16	300	4.3
8-232-050	4.5	7.4	1	1.61	8 UNC	2.81	3.17	2.34	0.98	6.38	4.92	1.73	1.46	5/8	1 1/2	400	5.7
8-232-078	6.25	9.6	1 1/4	2.09	7 UNC	3.43	3.66	2.23	1.18	8.07	5.83	2.44	1.79	7/8	1 7/8	500	11.0
8-232-125	10.0	11.0	1 1/2	2.40	6 UNC	4.29	4.38	3.87	1.42	9.92	7.40	3.07	2.22	1	2 1/4	800	21.2
8-232-200	16.0	16.0	2	3.00	4.5 UNC	4.61	3.80	4.46	1.42	9.93	7.71	3.35	2.38	1 1/4	3	2000	25.6

* Proof Load is 2.5 times the Working Load Limit on the 5:1 design factor.
* Bolt in GEOMET™ finished on request



Kind of attachment

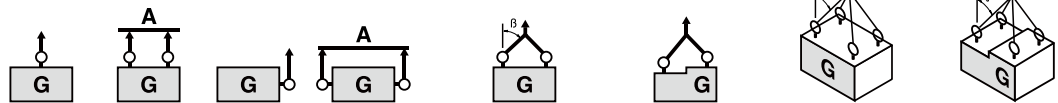

Number of legs	Thread	WLL(t)									
		1	2	1	2	2	2	2	3-4	3-4	3-4
Load direction		0°	0°	90°	90°	0-45°	45°-60°	unsymm.	0-45°	45°-60°	unsymm.
Item No.	Thread										
8-232-010	1/2	1.6	3.2	0.8	1.6	1.12	0.8	0.8	1.68	1.2	0.8
8-232-020	5/8	2.6	5.2	1.6	3.2	2.24	1.6	1.6	3.36	2.4	1.6
8-232-030	3/4	4	8	2.4	4.8	3.36	2.4	2.4	5.04	3.6	2.4
8-232-038	7/8	4.5	9	3	6	4.2	3	3	6.3	4.5	3
8-232-050	1	7.4	14.8	4	8	5.6	4	4	8.4	6	4
8-232-078	1 1/4	9.6	19.2	6.25	12.5	8.75	6.25	6.25	13.13	9.38	6.25
8-232-125	1 1/2	11	22	10	20	14	10	10	21	15	10
8-232-200	2	16	32	16	32	22.4	16	16	33.6	24	16

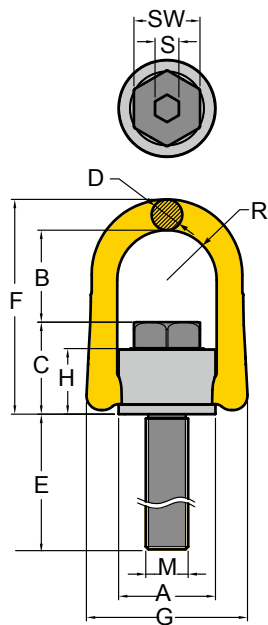

- Rotates through 360° and pivot 180°, and simultaneously allows lifting from any direction.
- Manufactured from forged alloy steel, quenched and tempered.
- Manufactured and tested in accordance with EN1677-1.
- Load rated parts are 100% magnaflux crack detected.
- Individual forged parts and cap screw are traceable to Test Certification.
- Bolt are Metric thread (ASME / ANSI B18.3.1M).
- Proof tested to 2.5 times the WLL.
- Fatigue rated to 1.5 times the WLL.
- All YOKE Lifting points meet or exceed all the requirements of ASME B30.26.
- Quick and simple assembly, just a tapped hole is required.

» Taiwan Patent
» China Patent

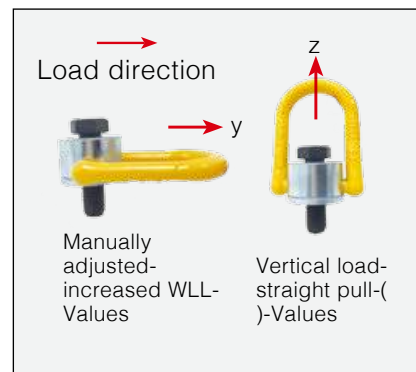

Anchor Point Long Bolt

Metric Thread (8-231)



Item No.	Working Load Limit		Thread version			Dimensions										Torque in		N.W.
	y	(z)	M	E	Pitch	A	B	C	D	F	G	H	R	S	SW	Nm	kg	
	tonnes		mm	mm	DIN13	mm												
8-231-005/105L	0.5	0.8	M 8	83	1.25	33	42	28	11	80	58	23	17	6	13	30	0.3	
8-231-007/125L	0.7	1.2	M 10	103	1.5	33	41	29	11	80	58	23	17	6	17	60	0.4	
8-231-010/150L	1.0	2.0	M 12	128	1.75	33	40	31	11	80	58	23	17	8	19	100	0.4	
8-231-020/185L	2.0	3.2	M 16	149	2	50	54	46	17	117	90	36	27	10	24	150	1.1	
8-231-030/230L	3.0	5.6	M 20	194	2.5	50	52	49	17	117	90	36	27	12	30	250	1.4	
8-231-050/265L	5.0	9.2	M 24	221	3	72	81	59	25	163	125	44	37	14	36	400	3.2	
8-231-078/340L	7.8	12.0	M 30	278	3.5	87	94	81	30	204	148	62	46	17	46	500	6.3	
8-231-125/300L	12.5	14.0	M 36	225	4	110	112	98	36	247	188	75	57	22	55	1000	10.9	
8-231-156/350L	15.6	16.0	M 42	268	4.5	110	101	108	36	247	188	83	57	24	65	1500	13.9	
8-231-200/385L	20.0	20.0	M 48	303	5	110	97	113	36	248	188	83	57	27	75	2000	14.7	

* Proof Load is 2.5 times the Working Load Limit on the 4:1 design factor.
* Bolt in GEOMET® finished on request



Kind of attachment

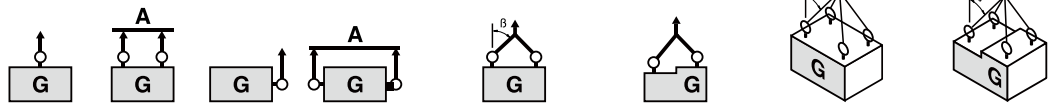

Number of legs	1		2		2		2		3-4		3-4	
	0°	90°	0°	90°	0-45°	45°-60°	unsymm.	0-45°	45°-60°	unsymm.	0-45°	45°-60°
Item No.	Thread	WLL(t)										
8-231-005/105L	M 8	0.8	1.6	0.5	1	0.7	0.5	0.5	1.1	0.8	0.5	
8-231-007/125L	M10	1.2	2.4	0.7	1.4	1	0.7	0.7	1.5	1.1	0.7	
8-231-010/150L	M12	2	4	1	2	1.4	1	1	2.1	1.5	1	
8-231-020/185L	M16	3.2	6.4	2	4	2.8	2	2	4.2	3	2	
8-231-030/230L	M20	5.6	11.2	3	6	4.2	3	3	6.3	4.5	3	
8-231-050/265L	M24	9.2	18.4	5	10	7	5	5	10.5	7.5	5	
8-231-078/340L	M30	12	24	7.8	15.6	10.9	7.8	7.8	16.4	11.7	7.8	
8-231-125/300L	M36	14	28	12.5	25	17.5	12.5	12.5	26.3	18.8	12.5	
8-231-156/350L	M42	16	32	15.6	31.2	21.8	15.6	15.6	32.8	23.4	15.6	
8-231-200/385L	M48	20	40	20	40	28	20	20	42	30	20	

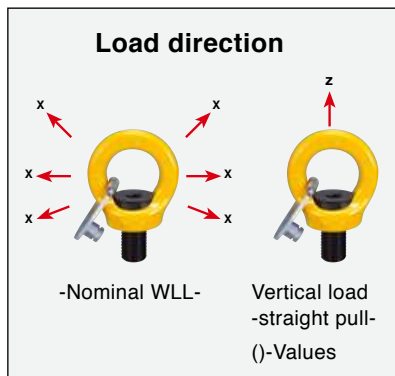
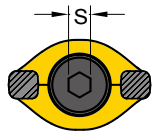
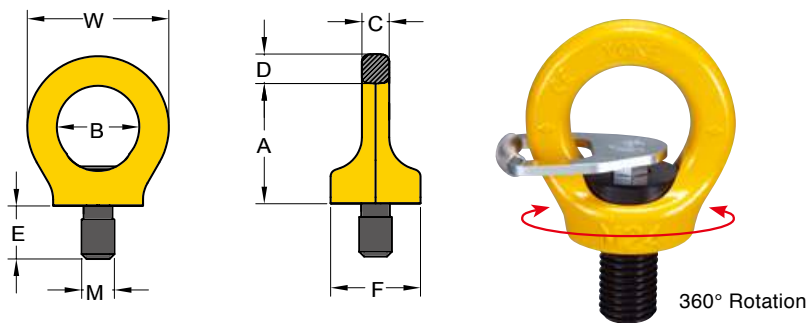

- Rotates through 360° adjustable in the direction of the load.
- Manufactured from alloy steel, quenched and tempered. Captive bolt with high WLL.
- Manufactured and tested in accordance with EN1677-1.
- Load rated parts are 100% magnaflux crack detected.
- Individual forged parts and cap screw are traceable to Test Certification.
- Bolts are Metric thread (ASME / ANSI B18.3.1M)
- Proof tested to 2.5 times the WLL.
- Fatigue rated to 1.5 times the WLL.
- All YOKE Lifting points meet or exceed all the requirements of ASME B30.26.
- Quick and simple assembly, just a tapped hole is required.

- » China Patent
- » French Patent
- » Australian Patent
- » Japanese Patent

Key Eye Point

Metric Thread (8-291K)



Item No.	Working Load Limit		Thread version			Dimensions						Torque in	N.W.	
	tonnes		M	E	Pitch	A	B	C	D	F	S	W		
	X	(Z)	mm	mm	DIN13				mm				Nm	kg
8-291K-003	0.3	(1)	M 8	12	1.25	36	25	8	9	25	6	44	10	0.1
8-291K-004	0.4	(1)	M 10	15	1.5	36	25	8	9	25	6	44	10	0.1
8-291K-007	0.75	(2)	M 12	18	1.75	45	30	10	11	33	8	52	10	0.2
8-291K-015	1.5	(4)	M 16	24	2	52	35	14	13	35	10	61	30	0.3
8-291K-023	2.3	(6)	M 20	30	2.5	60	40	16	15	44	12	70	70	0.6
8-291K-032	3.2	(8)	M 24	36	3	72	48	19	18	52	14	84	150	1.0
8-291K-045	4.5	(12)	M 30	45	3.5	90	60	24	22	60	17	105	350	1.8
8-291K-070	7.0	(16)	M 36	54	4	109	72	29	27	76	22	126	410	3.2
8-291K-090	9.0	(24)	M 42	63	4.5	123	82	34	32	88	24	147	550	5.0
8-291K-120	12.0	(32)	M 48	72	5	144	94	38	37	104	27	168	550	7.6
8-291K-140	12.0	(32)	M 56	84	5.5	147	102	40	43	124	27	178	800	9.2
8-291K-150	12.0	(32)	M 64	95	6	147	102	40	43	124	27	178	800	10.0

* Proof Load is 2.5 times the Working Load Limit on the 4:1 design factor.
 * Bolt in GEOMET™ finished on request



Kind of attachment

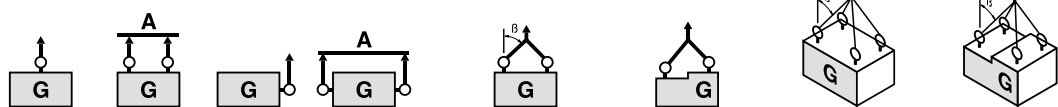

Number of legs	Load direction	WLL(t)									
		1	2	1	2	2	2	2	3-4	3-4	3-4
Item No.	Thread	0°	0°	90°	90°	0-45°	45° - 60°	unsymm.	0 - 45°	45° - 60°	unsymm.
8-291-003	M 8	1	2	0.3	0.6	0.42	0.3	0.3	0.63	0.45	0.3
8-291-004	M10	1	2	0.4	0.8	0.56	0.4	0.4	0.8	0.6	0.4
8-291-007	M12	2	4	0.75	1.5	1	0.75	0.75	1.5	1.1	0.75
8-291-015	M16	4	8	1.5	3	2.1	1.5	1.5	3.1	2.2	1.5
8-291-023	M20	6	12	2.3	4.6	3.2	2.3	2.3	4.8	3.4	2.3
8-291-032	M24	8	16	3.2	6.4	4.5	3.2	3.2	6.7	4.8	3.2
8-291-045	M30	12	24	4.5	9	6.3	4.5	4.5	9.4	6.7	4.5
8-291-070	M36	16	32	7	14	9.8	7	7	14.7	10.5	7
8-291-090	M42	24	48	9	18	12.6	9	9	18.9	13.5	9
8-291-120	M48	32	64	12	24	16.8	12	12	25	18	12
8-291-140	M56	32	64	12	24	16.8	12	12	25	18	12
8-291-150	M64	32	64	12	24	16.8	12	12	25	18	12

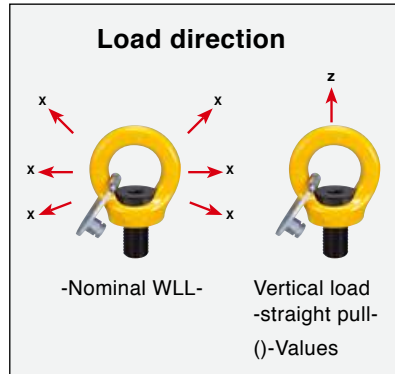
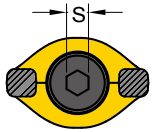
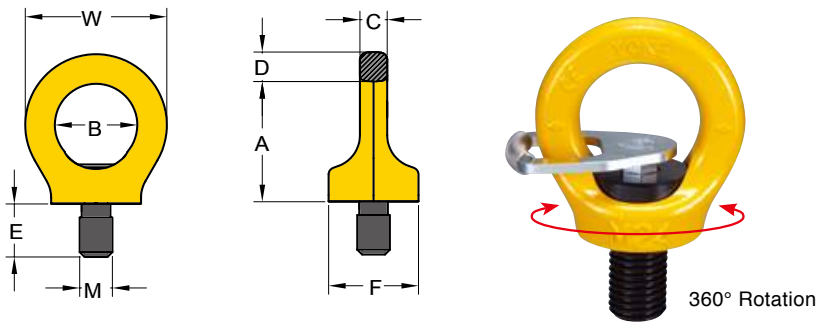

- Rotates through 360° adjustable in the direction of the load.
- Manufactured from alloy steel, quenched and tempered. Captive bolt with high WLL.
- Manufactured and tested in accordance with EN1677-1.
- Load rated parts are 100% magnaflux crack detected.
- Individual forged parts and cap screw are traceable to Test Certification.
- Bolts are UNC thread (ASME / ANSI B18.3.1M)
- Proof tested to 2.5 times the WLL.
- Fatigue rated to 1.5 times the WLL.
- All YOKE Lifting points meet or exceed all the requirements of ASME B30.26.
- Quick and simple assembly, just a tapped hole is required.

- » Chinese Patent
- » French Patent
- » Australian Patent
- » Japanese Patent

Key Eye Point

UNC Thread (8-292K)



Item No.	Working Load Limit		Thread version				Dimensions						Torque in		N.W.
	tonnes		M	E	TPI	A	B	C	D	F	S	W			
	X	(Z)	inch	inch				inch					Nm	lbs	
8-292K-003	0.3	(1)	5/16	0.47	18UNC	1.42	0.98	0.31	0.35	0.98	0.25	1.73	10	0.2	
8-292K-004	0.4	(1)	3/8	0.57	16UNC	1.42	0.98	0.31	0.35	0.98	0.25	1.73	10	0.2	
8-292K-007	0.75	(2)	1/2	0.75	13UNC	1.77	1.18	0.39	0.43	1.30	0.31	2.05	10	0.4	
8-292K-015	1.5	(4)	5/8	0.94	11UNC	2.05	1.38	0.55	0.51	1.38	0.37	2.40	30	0.7	
8-292K-023	2.3	(6)	3/4	1.13	10UNC	2.36	1.57	0.63	0.59	1.73	0.50	2.76	70	1.3	
8-292K-025	2.3	(6)	7/8	1.31	9UNC	2.36	1.57	0.63	0.59	1.73	0.50	2.76	150	1.3	
8-292K-032	3.2	(8)	1	1.5	8UNC	2.83	1.89	0.75	0.71	2.05	0.56	3.31	150	2.2	
8-292K-045	4.5	(12)	1 1/4	1.88	7UNC	3.54	2.36	0.94	0.87	2.36	0.63	4.13	350	4.0	
8-292K-070	7.0	(16)	1 1/2	2.25	6UNC	4.29	2.83	1.14	1.06	2.99	0.87	4.96	410	7.0	
8-292K-090	9.0	(24)	1 3/4	2.63	5UNC	4.84	3.23	1.34	1.26	3.46	1.00	5.79	550	11.0	
8-292K-120	12.0	(32)	2	3.00	4.5UNC	5.67	3.70	1.50	1.46	4.09	1.00	6.61	550	16.7	

* Proof Load is 2.5 times the Working Load Limit on the 4:1 design factor.



Kind of attachment

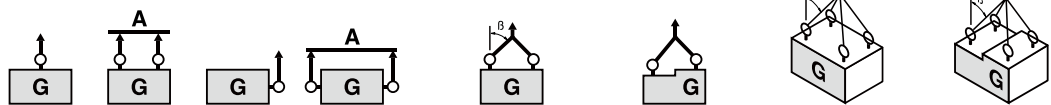

Number of legs	Load direction	WLL(t)										
		1	2	1	2	2	2	2	3-4	3-4	3-4	
Item No.	Thread	0°	0°	90°	90°	0-45°	45°- 60°	unsymm.	0 - 45°	45°- 60°	unsymm.	
8-292K-003	5/16	1	2	0.3	0.6	0.42	0.3	0.3	0.63	0.45	0.3	
8-292K-004	3/8	1	2	0.4	0.8	0.56	0.4	0.4	0.8	0.6	0.4	
8-292K-007	1/2	2	4	0.75	1.5	1	0.75	0.75	1.5	1.1	0.75	
8-292K-015	5/8	4	8	1.5	3	2.1	1.5	1.5	3.1	2.2	1.5	
8-292K-023	3/4	6	12	2.3	4.6	3.2	2.3	2.3	4.8	3.4	2.3	
8-292K-025	7/8	6	12	2.3	4.6	3.2	2.3	2.3	4.8	3.4	2.3	
8-292K-032	1	8	16	3.2	6.4	4.5	3.2	3.2	6.7	4.8	3.2	
8-292K-045	1 1/4	12	24	4.5	9	6.3	4.5	4.5	9.4	6.7	4.5	
8-292K-070	1 1/2	16	32	7	14	9.8	7	7	14.7	10.5	7	
8-292K-090	1 3/4	24	48	9	18	12.6	9	9	18.9	13.5	9	
8-292K-120	2	32	64	12	24	16.8	12	12	25	18	12	

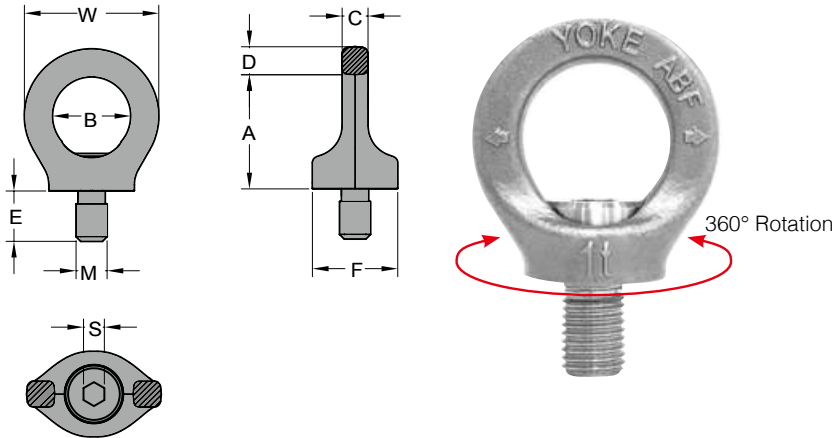

- Rotates through 360° adjustable in the direction of the load.
- Manufactured from stainless steel, quenched and tempered. Captive bolt with high WLL.
- Manufactured and tested in accordance with GS-OA-15-04.
- Individual forged parts and cap screw are traceable to Test Certification.
- Proof tested to 2.5 times the WLL.
- Fatigue rated to 1.5 times the WLL.
- All YOKE Lifting points meet or exceed all the requirements of ASME B30.26.
- Quick and simple assembly, just a tapped hole is required.
- Used in different applications such as chemical, oil, coal industries, food processing, clean room and precision instrument.

- » China Patent
- » French Patent
- » Australian Patent
- » Japanese Patent

Stainless Steel Eye Point

Metric Thread (8-S291)



Item No.	Working Load Limit		Thread version			Dimensions							Torque		N.W.
	X	(Z)	M	E	Pitch	A	B	C	D	F	S	W	Nm	kg	
	tonnes		mm	mm	DIN13				mm						
8-S291-005	0.5	1.2	M 12	18	1.75	45	30	10	11	33	8	52	10	0.2	
8-S291-010	1	2.4	M 16	24	2	52	35	14	13	35	10	61	30	0.3	
8-S291-020	2	3.6	M 20	30	2.5	60	40	16	15	44	12	70	70	0.6	
8-S291-025	2.5	5.2	M 24	36	3	72	48	19	18	52	14	84	150	1.0	

* Proof Load is 2.5 times the Working Load Limit on the 4:1 design factor.



Kind of attachment

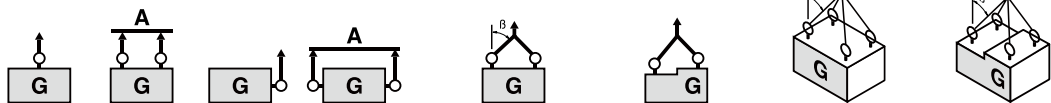

Number of legs	Load direction	WLL(t)									
		1	2	1	2	2	2	2	3-4	3-4	3-4
Item No.	Thread	0°	0°	90°	90°	0-45°	45° - 60°	unsymm.	0 - 45°	45° - 60°	unsymm.
8-S291-005	M12	1.2	2.4	0.5	1	0.7	0.5	0.5	1	0.7	0.5
8-S291-010	M16	2.4	4.8	1	2	1.4	1	1	2.1	1.5	1
8-S291-020	M20	3.6	7.2	2	4	2.8	2	2	4.2	3	2
8-S291-025	M24	5.2	10.4	2.5	5	3.5	2.5	2.5	5.3	3.7	2.5

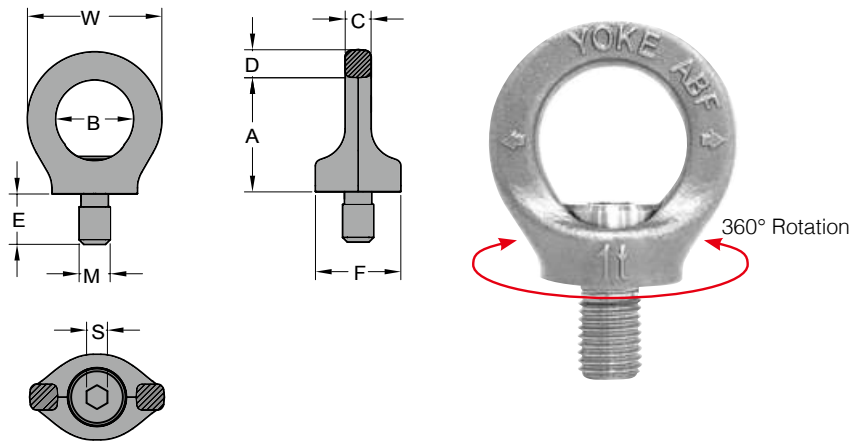

- Rotates through 360° adjustable in the direction of the load.
- Manufactured from stainless steel, quenched and tempered. Captive bolt with high WLL.
- Manufactured and tested in accordance with GS-OA-15-04.
- Individual forged parts and cap screw are traceable to Test Certification.
- Proof tested to 2.5 times the WLL..
- Fatigue rated to 1.5 times the WLL.
- All YOKE Lifting points meet or exceed all the requirements of ASME B30.26.
- Quick and simple assembly, just a tapped hole is required.
- Used in different applications such as chemical, oil, coal industries, food processing, clean room and precision instrument.

- » Chinese Patent
- » French Patent
- » Australian Patent
- » Japanese Patent

Stainless Steel Eye Point

UNC Thread (8-S292)



Item No.	Working Load Limit		Thread version			Dimensions						Torque		N.W.
	X	(Z)	M	E	TPI	A	B	C	D	F	S	W	in	
	tonnes		inch	inch				inch					Nm	lbs
8-S292-005	0.5	1.2	1/2	0.75	13UNC	1.77	1.18	0.39	0.43	1.30	0.31	2.05	10	0.4
8-S292-010	1	2.4	5/8	0.94	11UNC	2.05	1.38	0.55	0.51	1.38	0.37	2.40	30	0.7
8-S292-020	2	3.6	3/4	1.13	10UNC	2.36	1.57	0.63	0.59	1.73	0.50	2.76	70	1.3
8-S292-025	2.5	5.2	1	1.5	8UNC	2.83	1.89	0.75	0.71	2.05	0.56	3.31	150	2.2

* Proof Load is 2.5 times the Working Load Limit on the 4:1 design factor.



Kind of attachment

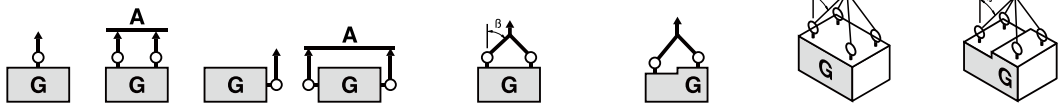

Number of legs	1		2		2		2		3-4		3-4	
	0°	0°	90°	90°	0-45°	45°- 60°	unsymm.	0 - 45°	45°- 60°	unsymm.		
Item No.	Thread	WLL(t)										
8-S292-005	1/2	1.2	2.4	0.5	1	0.7	0.5	0.5	1	0.7	0.5	
8-S292-010	5/8	2.4	4.8	1	2	1.4	1	1	2.1	1.5	1	
8-S292-020	3/4	3.6	7.2	2	4	2.8	2	2	4.2	3	2	
8-S292-025	1	5.2	10.4	2.5	5	3.5	2.5	2.5	5.3	3.7	2.5	

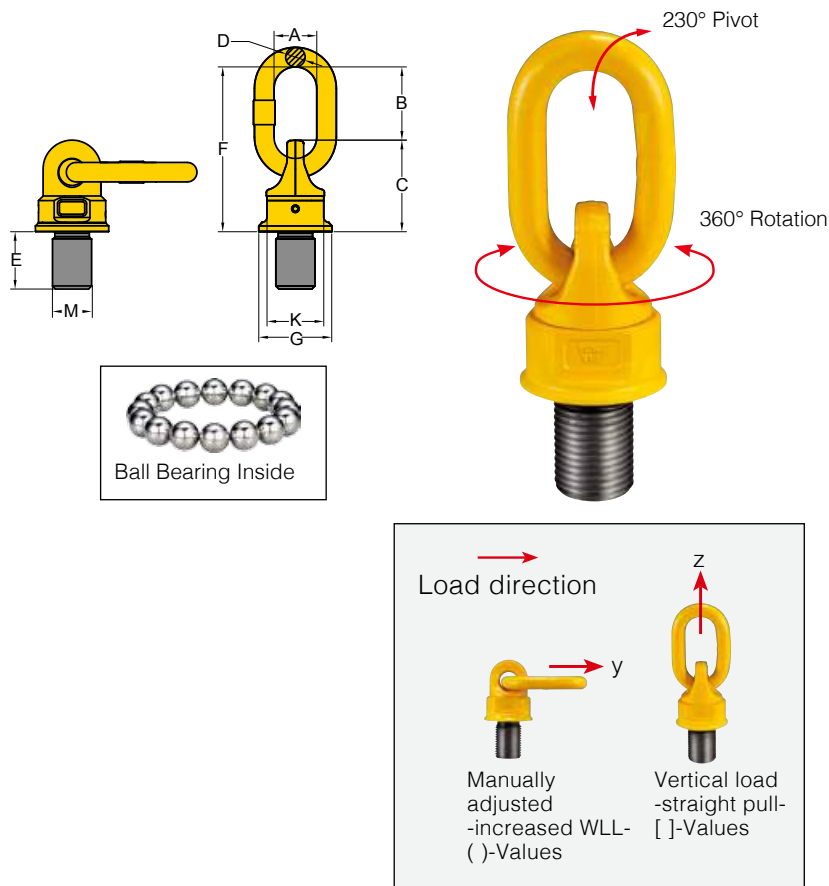

- Pivots more than 230°, rotates through 360° due to its unique ball bearing design. Design factor 4:1 in all directions.
- Manufactured from forged alloy steel, quenched and tempered.
- Manufactured and tested in accordance with EN1677-1.
- Load rated parts are 100% magnaflux crack detected.
- Individual forged parts and cap screw are traceable to Test Certification.
- Proof tested to 2.5 times the WLL.
- Fatigue rated to 1.5 times the WLL.
- All YOKE Lifting points meet or exceed all the requirements of ASME B30.26.
- Easy to attach or dismantle due to the forged hexagon shaped body of the Super Point.
- Maximum WLL in axial direction when load ring is aligned.
- Capable of rotating under load. Do not turn continuously in 90 degree direction at full load.

Swivel Point

Metric Thread (8-271)



Item No.	Working Load Limit		Thread version			Dimensions (mm)						Torque	N.W.	
	(y)	[z]	M	E	Pitch	G	C	K	F	D	B	A	Nm	kg
	tonnes		mm	mm	DIN13				mm					
8-271-003	0.4	0.6	M 8	12	1.25	35	40	30	72	8	32	29	10 - 40	0.2
8-271-004	0.6	0.9	M 10	15	1.5	35	40	30	72	8	32	29	10 - 40	0.2
8-271-006	0.7	1.2	M 12	18	1.75	40	45	36	95	10	50	35	15 - 40	0.3
8-271-013	1.5	2.6	M 16	24	2	46	54	41	104	13	50	38	45 - 130	0.5
8-271-020	2.5	4	M 20	30	2.5	62	68	55	122	13	54	38	100 - 170	1.0
8-271-035	4	7	M 24	36	3	78	88	70	154	19	66	40	190 - 280	2.2
8-271-060	6	10	M 30	46	3.5	90	120	80	206	22	86	50	270 - 600	4.5
8-271-080	10	15	M 36	55	4	90	120	80	206	22	86	50	270 - 600	4.6
8-271-120	13	17	M 42	64	4.5	98	122	84	235	25	110	65	350 - 800	5.5
8-271-130	14	18	M 48	73	5	98	122	84	235	25	110	65	350 - 800	6.1
8-271-140	20	25	M 52	79	5	120	150	94	270	32	120	70	350 - 900	10.5
8-271-160	20	28	M 56	85	5.5	120	150	94	270	32	120	70	350 - 900	10.7
8-271-161	20	28	M 64	95	6	120	150	94	270	32	120	70	500 - 1000	11.6

* Proof Load is 2.5 times the Working Load Limit on the 4:1 design factor.
 * Bolt in GEOMET[®] finished on request
 * Please refer to 8-251 table for specification \geq M72



Kind of attachment											
Number of legs		1	2	1	2	2	2	2	3-4	3-4	3-4
Load direction		0°	0°	90°	90°	0-45°	45°- 60°	unsymm.	0 - 45°	45°- 60°	unsymm.
Item No.	Thread	WLL(t)									
8-271-003	M 8	0.6	1.2	0.4	0.8	0.4	0.3	0.3	0.6	0.4	0.3
8-271-004	M10	0.9	1.8	0.6	1.2	0.6	0.4	0.4	0.9	0.6	0.4
8-271-006	M12	1.2	2.4	0.7	1.5	0.8	0.6	0.6	1.2	0.9	0.6
8-271-013	M16	2.6	5.2	1.5	3	1.8	1.3	1.3	2.7	1.9	1.3
8-271-020	M20	4	8	2.5	5	2.8	2	2	4.2	3	2
8-271-035	M24	7	14	4	8	4.9	3.5	3.5	7.3	5.2	3.5
8-271-060	M30	10	20	6	12	7	5	5	10.5	7.5	5
8-271-080	M36	15	30	10	20	14	10	10	21	15	10
8-271-120	M42	17	34	13	26	18.2	13	13	27.3	19.5	13
8-271-130	M48	18	36	14	28	19.6	14	14	29.4	21	14
8-271-140	M52	25	50	20	40	28	20	20	42	30	20
8-271-160	M56	28	56	20	40	28	20	20	42	30	20
8-271-161	M64	28	56	20	40	28	20	20	42	30	20

* Please refer to 8-251 table for specification \geq M72

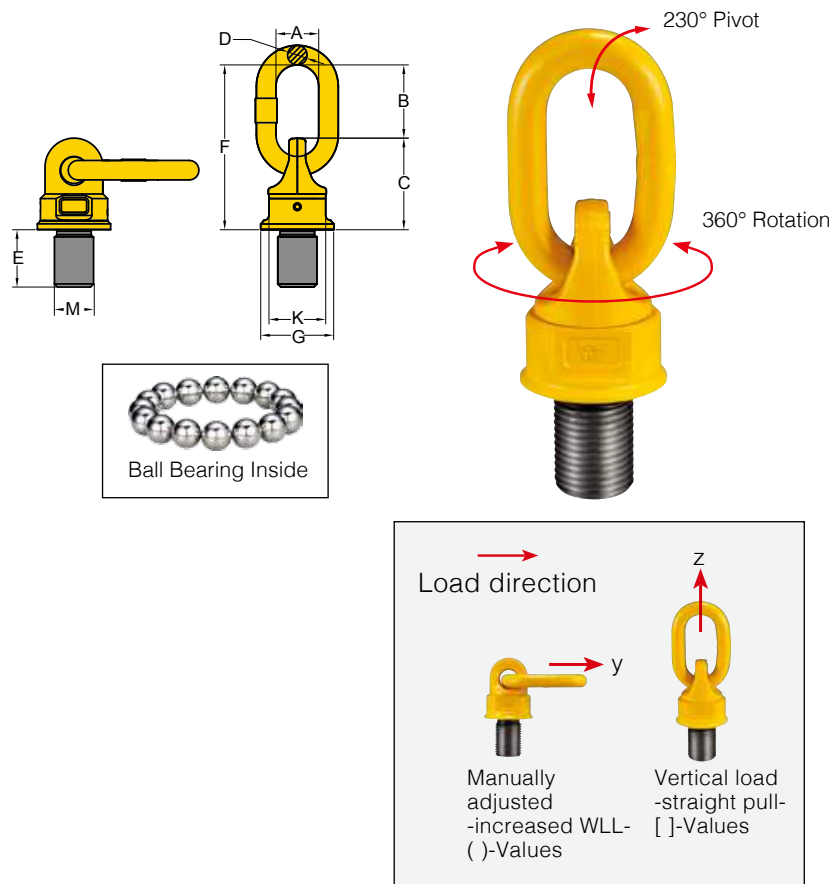

- Pivots more than 230°, rotates through 360° due to its unique ball bearing design. Design factor 4:1 in all directions.
- Manufactured from forged alloy steel, quenched and tempered.
- Manufactured and tested in accordance with EN1677-1.
- Load rated parts are 100% magnaflux crack detected.
- Individual forged parts and cap screw are traceable to Test Certification.
- Proof tested to 2.5 times the WLL.
- Fatigue rated to 1.5 times the WLL.
- All YOKE Lifting points meet or exceed all the requirements of ASME B30.26.
- Easy to attach or dismantle due to the forged hexagon shaped body of the Super Point.
- Maximum WLL in axial direction when load ring is aligned.
- Capable of rotating under load. Do not turn continuously in 90 degree direction at full load.

Swivel Point

UNC Thread (8-272)



Item No.	Working Load Limit		Thread version				Dimensions						Torque		N.W.
	(y)	[z]	M	E	TPI	G	C	K	F	D	B	A	in		
	tonnes		inch	inch					inch				Nm	lbs	
8-272-006	0.7	1.2	1/2	0.75	13UNC	1.57	1.77	1.42	3.74	0.39	1.97	1.38	15 - 40	0.7	
8-272-013	1.5	2.6	5/8	0.94	11UNC	1.81	2.13	1.61	4.09	0.51	1.97	1.50	45 - 130	1.2	
8-272-018	2	3.6	3/4	1.13	10UNC	1.81	2.68	1.61	4.09	0.51	1.97	1.50	45 - 130	1.2	
8-272-020	2.5	4	7/8	1.31	9UNC	2.44	2.68	2.17	4.80	0.51	2.13	1.50	100 - 170	2.2	
8-272-035	4	7	1	1.50	8UNC	3.07	3.46	2.76	6.06	0.75	2.60	1.57	190 - 280	4.8	
8-272-060	6	10	1 1/4	1.88	7UNC	3.54	4.72	3.15	8.11	0.87	3.39	1.97	270 - 600	9.9	
8-272-080	10	15	1 1/2	2.25	6UNC	3.54	4.72	3.15	8.11	0.87	3.39	1.97	270 - 600	10.0	
8-272-120	13	17	1 3/4	2.63	5UNC	3.86	4.80	3.31	9.25	0.98	4.33	2.56	350 - 800	12.1	
8-272-130	14	18	2	3.00	4.5UNC	3.86	4.80	3.31	9.25	0.98	4.33	2.56	350 - 800	13.5	
8-272-140	20	25	2 1/4	3.38	4.5UNC	4.72	5.91	3.70	10.63	1.26	4.72	2.76	350 - 900	23.1	
8-272-160	20	28	2 1/2	3.75	4UNC	4.72	5.91	3.70	10.63	1.26	4.72	2.76	350 - 900	23.5	

* Proof Load is 2.5 times the Working Load Limit on the 4:1 design factor.
 * Bolt in GEOMET[®] finished on request
 * Please refer to 8-252 table for specification \geq 3-4UNC.



Kind of attachment																
	Number of legs	Load direction	1	2	1	2	2	2	2	3-4	3-4	3-4	3-4	3-4	3-4	
Item No.	Thread	0°	0°	90°	90°	0-45°	45°-60°	unsymm.	0-45°	45°-60°	unsymm.	0-45°	45°-60°	unsymm.		
		WLL(t)														
8-272-006	1/2	1.2	2.4	0.7	1.5	0.8	0.6	0.6	1.2	0.9	0.6	1.2	0.9	0.6		
8-272-013	5/8	2.6	5.2	1.5	3	1.8	1.3	1.3	2.7	1.9	1.3	2.7	1.9	1.3		
8-272-018	3/4	3.6	7.2	2	4	2.5	1.8	1.8	3.7	2.7	1.8	3.7	2.7	1.8		
8-272-020	7/8	4	8	2.5	5	2.8	2	2	4.2	3	2	4.2	3	2		
8-272-035	1	7	14	4	8	4.9	3.5	3.5	7.3	5.2	3.5	7.3	5.2	3.5		
8-272-060	1 1/4	10	20	6	12	7	5	5	10.5	7.5	5	10.5	7.5	5		
8-272-080	1 1/2	15	30	10	20	14	10	10	21	15	10	21	15	10		
8-272-120	1 3/4	17	34	13	26	18.2	13	13	27.3	19.5	13	27.3	19.5	13		
8-272-130	2	18	36	14	28	19.6	14	14	29.4	21	14	29.4	21	14		
8-272-140	2 1/4	25	50	20	40	28	20	20	42	30	20	42	30	20		
8-272-160	2 1/2	28	56	20	40	28	20	20	42	30	20	42	30	20		

* Please refer to 8-252 table for specification \geq 3-4UNC.



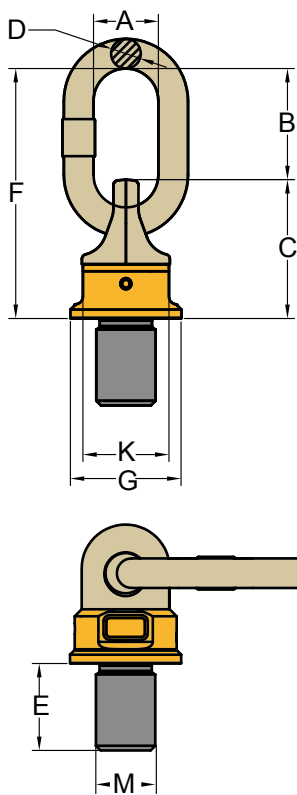

- Pivots more than 230°, rotates through 360° due to its unique ball bearing design. Design factor 4:1 in all directions.
- Manufactured from forged alloy steel, quenched and tempered.
- Manufactured and tested in accordance with EN1677-1.
- Load rated parts are 100% magnaflux crack detected.
- Fatigue rated to 1.5 times the WLL.
- All YOKE Super points meet or exceed all the requirements of ASME B30.26.
- Easy to attach or dismantle due to the forged hexagon shaped body of the Super Point.

Super Point

Metric Thread (8-251)



Super Point

UNC Thread (8-252)



* Proof Load is 2.5 times the Working Load Limit on the 4:1 design factor.
 * Bolt in GEOMET[™] finished on request

Super Point

Metric Thread (8-251)

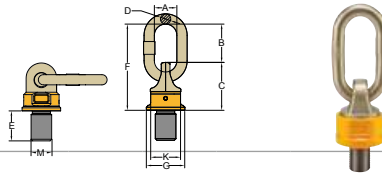

Item No.	Working Load Limit		Thread version			Dimensions							Torque	N.W.
	y	(z)	M	E	TPI	G	C	K	F	D	B	A	Nm	kg
	tonnes		mm	mm	DIN13				mm					
8-251-007-01	0.5	1	M10	18	1.5	36.5	48	34	101	13	53	35	10 - 40	0.4
8-251-007-02	0.7	1.4	M12	18	1.75	36.5	48	34	101	13	53	35	15 - 40	0.4
8-251-007-03	0.7	1.4	M12	25	1.75	36.5	48	34	101	13	53	35	15 - 40	0.4
8-251-007-04	1	2	M14	20	2	36.5	48	34	101	13	53	35	30 - 40	0.4
8-251-014-01	1.4	2.8	M16	20	2	36.5	48	34	101	13	53	35	45 - 130	0.44
8-251-014-02	1.4	2.8	M16	24	2	36.5	48	34	101	13	53	35	45 - 130	0.5
8-251-014-03	1.4	2.8	M16	30	2	36.5	48	34	101	13	53	35	45 - 130	0.5
8-251-014-04	1.7	3.4	M20	30	2.5	36.5	48	34	101	13	53	35	75 - 130	0.5
8-251-014-05	1.7	3.4	M24	30	3	36.5	48	34	101	13	53	35	90 - 130	0.5
8-251-025-01	2.5	5	M20	30	2.5	52	68	46	127	16	59	35	100 - 170	1.0
8-251-025-02	2.5	5	M20	40	2.5	52	68	46	127	16	59	35	100 - 170	1.0
8-251-025-03	2.5	5	M20	50	2.5	52	68	46	127	16	59	35	100 - 170	1.1
8-251-025-04	2.5	5	M20	70	2.5	52	68	46	127	16	59	35	100 - 170	1.1
8-251-040-01	4	8	M24	30	3	57	75	50	148	19	73	40	190 - 280	1.5
8-251-040-02	4	8	M24	36	3	57	75	50	148	19	73	40	190 - 280	1.5
8-251-040-03	4	8	M24	45	3	57	75	50	148	19	73	40	190 - 280	1.5
8-251-040-04	4	8	M24	50	3	57	75	50	148	19	73	40	190 - 280	1.5
8-251-040-05	4	8	M30	35	3.5	57	75	50	148	19	73	40	190 - 280	1.5
8-251-067-01	6.7	12	M30	35	3.5	70	95	65	163	19	68	40	230 - 400	2.4
8-251-067-02	6.7	12	M30	45	3.5	70	95	65	163	19	68	40	230 - 400	2.4
8-251-067-03	6.7	12	M30	50	3.5	70	95	65	163	19	68	40	230 - 400	2.5
8-251-067-04	6.7	12	M30	60	3.5	70	95	65	163	19	68	40	230 - 400	2.5
8-251-080-01	8	12	M30	35	3.5	81	106	75	201	22	95	50	270 - 600	3.6
8-251-080-02	8	12	M30	45	3.5	81	106	75	201	22	95	50	270 - 600	3.7
8-251-100-01	10	15	M36	50	4	81	106	75	201	22	95	50	270 - 600	3.8
8-251-100-02	10	15	M36	54	4	81	106	75	201	22	95	50	270 - 600	3.9
8-251-125-01	12.5	15	M42	50	4.5	81	106	75	201	22	95	50	270 - 700	3.9
8-251-125-02	12.5	15	M42	60	4.5	81	106	75	201	22	95	50	270 - 700	4.0
8-251-125-03	12.5	15	M42	63	4.5	81	106	75	201	22	95	50	270 - 700	4.0
8-251-125-04	12.5	15	M45	60	4.5	81	106	75	201	22	95	50	270 - 700	4.1
8-251-125-05	12.5	15	M48	72	5	81	106	75	201	22	95	50	270 - 700	4.4
8-251-170-01	13	20	M42	60	4.5	104	127	95	256	32	129	70	350 - 800	7.4
8-251-170-02	17	25	M45	60	4.5	104	127	95	256	32	129	70	350 - 800	7.5
8-251-170-03	17	25	M48	60	5	104	127	95	256	32	129	70	350 - 800	7.6
8-251-170-04	17	25	M48	72	5	104	127	95	256	32	129	70	350 - 800	7.7
8-251-170-05	18	25	M56	78	5.5	104	127	95	256	32	129	70	350 - 900	8.1
8-251-170-06	18	25	M56	85	5.5	104	127	95	256	32	129	70	350 - 900	8.1
8-251-200-01	20	25	M64	96	6	104	127	95	256	32	129	70	350 - 900	8.9
8-251-200-02	20	25	M64	110	6	104	127	95	256	32	129	70	350 - 900	9.3
8-251-280-01	28	32.5	M64	96	6	129	174	115	305	36	131	80	500 - 1000	16.4
8-251-280-02	28	32.5	M72	120	6	129	174	115	305	36	131	80	500 - 1200	17.7
8-251-280-03	28	32.5	M80	150	6	129	174	115	305	36	131	80	500 - 1200	19.6
8-251-350-01	35	40	M80	120	6	148	187	135	366	45	179	100	500 - 1400	25.3
8-251-350-02	35	40	M90	150	6	148	187	135	366	45	179	100	500 - 1500	27.8
8-251-400-01	40	50	M80	120	6	170	210	145	340	45	130	90	500 - 1500	31.9
8-251-400-02	40	50	M90	115	6	170	210	145	340	45	130	90	500 - 1500	33.6
8-251-400-03	40	50	M90	150	6	170	210	145	340	45	130	90	500 - 1500	34.2
8-251-400-04	40	50	M100	150	6	170	210	145	340	45	130	90	500 - 1700	35.2



Kind of attachment											
Number of legs	Load direction	1	2	1	2	2	2	2	3-4	3-4	3-4
		0°	0°	90°	90°	0-45°	45°- 60°	unsymm.	0 - 45°	45°- 60°	unsymm.
Item No.	Thread	WLL(t)									
8-251-007	M10	1	2	0.5	1	0.7	0.5	0.5	1	0.75	0.75
	M12	1.4	2.8	0.7	1.4	1	0.7	0.7	1.4	1	1
	M14	2	4	1	2	1.4	1	1	2.12	1.5	1.5
8-251-014	M16	2.8	5.6	1.4	2.8	2	1.4	1.4	3	2.12	2.12
	M20	3.4	6.8	1.7	3.4	2.4	1.7	1.7	3.55	2.5	2.5
	M24	3.4	6.8	1.7	3.4	2.4	1.7	1.7	3.55	2.5	2.5
8-251-025	M20	5	10	2.5	5	3.55	2.5	2.5	5.3	3.75	3.75
8-251-040	M24	8	16	4	8	5.6	4	4	8.5	6	6
	M30	8	16	4	8	5.6	4	4	8.5	6	6
8-251-067	M30	12	24	6.7	13.4	9.5	6.7	6.7	14	10	10
8-251-080	M30	12	24	8	16	11.2	8	8	16	12	12
8-251-100	M36	15	30	10	20	14	10	10	21.2	15	15
8-251-125	M42	15	30	12.5	25	17	12.5	12.5	25	18	18
	M45	15	30	12.5	25	17	12.5	12.5	25	18	18
	M48	15	30	12.5	25	17	12.5	12.5	25	18	18
8-251-170	M42	20	40	13	26	18	13	13	27	19	19
	M45	25	50	17	34	23.5	17	17	35	25	25
	M48	25	50	17	34	23.5	17	17	35	25	25
8-251-200	M56	25	50	18	36	25	18	18	37.5	26.5	26.5
	M64	25	50	20	40	28	20	20	42.5	30	30
8-251-280	M64	32.5	65	28	56	39	28	28	58	42	42
	M72	32.5	65	28	56	39	28	28	58	42	42
	M80	32.5	65	28	56	39	28	28	58	42	42
8-251-350	M80	40	80	35	70	49	35	35	74	52.5	52.5
	M90	40	80	35	70	49	35	35	74	52.5	52.5
8-251-400	M80	50	100	40	80	56	40	40	84	60	60
	M90	50	100	40	80	56	40	40	84	60	60
	M100	50	100	40	80	56	40	40	84	60	60

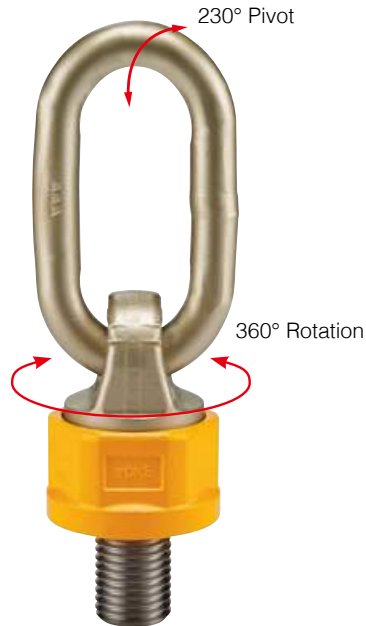
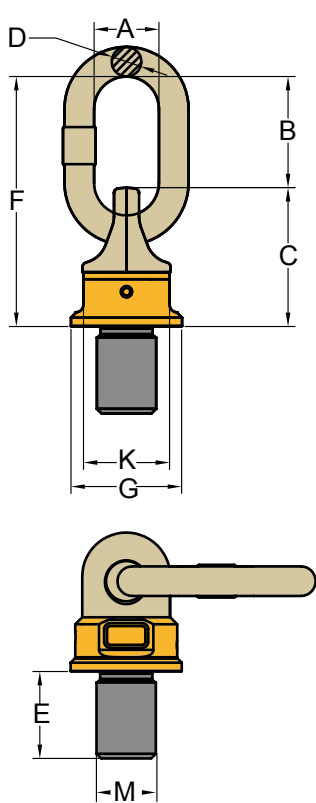

- Pivots more than 230°, rotates through 360° due to its unique ball bearing design. Design factor 4:1 in all directions.
- Secured four times against breakage in all load directions.
- Manufactured from forged alloy steel, quenched and tempered. Manufactured and tested in accordance with EN1677-1.
- Load rated parts are 100% magnaflux crack detected.
- Fatigue rated to 1.5 times the WLL.
- All YOKE Super points meet or exceed all the requirements of ASME B30.26.
- Easy to attach or dismantle due to the forged hexagon shaped body of the Super Point.

Super Point

UNC Thread (8-252)



Item No.	Working Load Limit		Thread version			Dimensions						Torque	N.W.	
	y	(z)	M	E	TPI	G	C	K	F	D	B	A	in	
	tonnes		inch	inch					inch				Nm	lbs
8-252-007-01	0.5	1	3/8	0.56	16UNC	1.44	1.89	1.34	3.98	0.51	2.09	1.38	10 - 40	1.0
8-252-007-02	0.7	1.4	1/2	0.75	13UNC	1.44	1.89	1.34	3.98	0.51	2.09	1.38	15 - 40	1.0
8-252-014-02	1.4	2.8	5/8	0.94	11UNC	1.44	1.89	1.34	3.98	0.51	2.09	1.38	45 - 130	1.0
8-252-025-01	2.5	5	3/4	1.13	10UNC	2.05	2.68	1.81	5.00	0.63	2.32	1.38	100 - 170	2.1
8-252-040-02	4	8	1	1.50	8UNC	2.24	2.95	1.97	5.83	0.75	2.87	1.57	190 - 280	3.3
8-252-067-02	6.7	12	1 1/4	1.88	7UNC	2.76	3.74	2.56	6.42	0.75	2.68	1.57	230 - 400	5.3
8-252-080-02	8	12	1 1/4	1.88	7UNC	3.19	4.17	2.95	7.91	0.87	3.74	1.97	270 - 600	8.1
8-252-100-01	10	15	1 1/2	2.08	6UNC	3.19	4.17	2.95	7.91	0.87	3.74	1.97	270 - 600	8.3
8-252-125-03	12.5	15	1 3/4	2.63	5UNC	3.19	4.17	2.95	7.91	0.87	3.74	1.97	270 - 700	8.8
8-252-170-01	13	20	1 3/4	2.63	5UNC	4.09	5.00	3.74	10.08	1.26	5.08	2.76	350 - 800	16.2
8-252-170-04	17	25	2	3.00	4.5UNC	4.09	5.00	3.74	10.08	1.26	5.08	2.76	350 - 800	16.7
8-252-170-06	18	25	2 1/4	3.42	4.5UNC	4.09	5.00	3.74	10.08	1.26	5.08	2.76	350 - 900	17.8
8-252-200-01	20	25	2 1/2	3.75	4UNC	4.09	5.00	3.74	10.08	1.26	5.08	2.76	350 - 900	19.6
8-252-280-01	28	32.5	2 1/2	3.75	4UNC	5.08	6.85	4.53	12.01	1.42	5.16	3.15	500 - 1000	36.1
8-252-350-01	35	40	3 1/2	5.25	4UNC	5.83	7.36	5.31	14.41	1.77	7.05	3.94	500 - 1400	55.7



Kind of attachment												
	Number of legs	1	2	1	2	2	2	2	2	3-4	3-4	3-4
Load direction	0°	0°	90°	90°	0-45°	45°- 60°	unsymm.	0 - 45°	45°- 60°	unsymm.		
Item No.	Thread	WLL(t)										
8-252-007	3/8	1	2	0.5	1	0.7	0.5	0.5	1	0.75	0.75	
	1/2	1.4	2.8	0.7	1.4	1	0.7	0.7	1.4	1	1	
8-252-014	5/8	2.8	5.6	1.4	2.8	2	1.4	1.4	3	2.12	2.12	
8-252-025	3/4	5	10	2.5	5	3.55	2.5	2.5	5.3	3.75	3.75	
8-252-040	1	8	16	4	8	5.6	4	4	8.5	6	6	
8-252-067	1 1/4	12	24	6.7	13.4	9.5	6.7	6.7	14	10	10	
8-252-080	1 1/4	12	24	8	16	11.2	8	8	16	12	12	
8-252-100	1 1/2	15	30	10	20	14	10	10	21.2	15	15	
8-252-125	1 3/4	15	30	12.5	25	17	12.5	12.5	25	18	18	
	1 3/4	20	40	13	26	18	13	13	27	19	19	
8-252-170	2	25	50	17	34	23.5	17	17	35	25	25	
	2 1/4	25	50	18	36	25	18	18	37.5	26.5	26.5	
8-252-200	2 1/2	25	50	20	40	28	20	20	42.5	30	30	
8-252-280	2 1/2	32.5	65	28	56	39	28	28	58	42	42	
8-252-350	3 1/2	40	80	35	70	49	35	35	74	52.5	52.5	

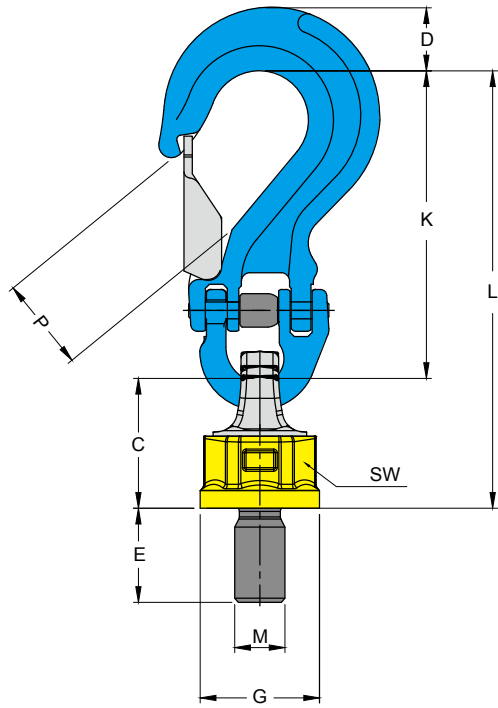

- Rotates through 360° adjustable in the direction of the load.
- Tested in accordance with EN1677-1.
- Load rated parts are 100% magnaflux crack detected.
- Individual forged parts and cap screw are traceable to Test Certification.
- Proof tested to 2.5 times the WLL.
- Fatigue rated to 1.5 times the WLL.
- Hook connecting to any ring structure quickly and safely without additional fittings required
- Ball bearing for turning/rotating under full load.

Hook Point

Metric Thread (8-2511)

Item No.	Working Load Limit tonnes	Thread version			Dimensions								Torque in		N.W. kg
		M mm	E mm	Pitch DIN13	G	C	K	F mm	D	B	A	Nm			
8-2511-014	1.4	M16	24	16UNC	36.5	40	34	124	20	164	23	10 - 40	0.8		
8-2511-025	2.5	M20	30	13UNC	52	55	46	121	23	176	30	15 - 40	1.4		
8-2511-040	4	M24	36	11UNC	57	63	50	149	31	212	36	45 - 130	2.4		
8-2511-067	6.7	M30	45	10UNC	70	78	65	186	36	264	42	100 - 170	4.2		
8-2511-100	10	M36	54	8UNC	81	86	75	216	45	302	47	190 - 280	6.9		
8-2511-130	13	M42	60	7UNC	104	104	95	251	48	355	52	230 - 400	12.1		
8-2511-160	16	M48	72	7UNC	104	104	95	251	48	355	52	270 - 600	12.4		

* Proof Load is 2.5 times the Working Load Limit on the 4:1 design factor.



Kind of attachment																				
	Number of legs	1	2	1	2	2	2	2	2	2	3-4	3-4	3-4	3-4	3-4	3-4	3-4	3-4	3-4	
Load direction	0°	0°	90°	90°	0-45°	45°- 60°	unsymm.	0 - 45°	45°- 60°	unsymm.	0 - 45°	45°- 60°	unsymm.	0 - 45°	45°- 60°	unsymm.	0 - 45°	45°- 60°	unsymm.	
Item No.	WLL(t)																			
8-2511-014	M16	1.4	2.8	1.4	2.8	2	1.4	1.4	3	2.12	2.12									
8-2511-025	M20	2.5	5	2.5	5	3.55	2.5	2.5	5.3	3.75	3.75									
8-2511-040	M24	4	8	4	8	5.6	4	4	8.5	6	6									
8-2511-067	M30	6.7	13.4	6.7	13.4	9.5	6.7	6.7	14	10	10									
8-2511-100	M36	10	20	10	20	14	10	10	21.2	15	15									
8-2511-130	M42	13	26	13	26	18	13	13	27	19	19									
8-2511-160	M48	16	32	16	32	22.0	16	16	33	23.5	23.5									

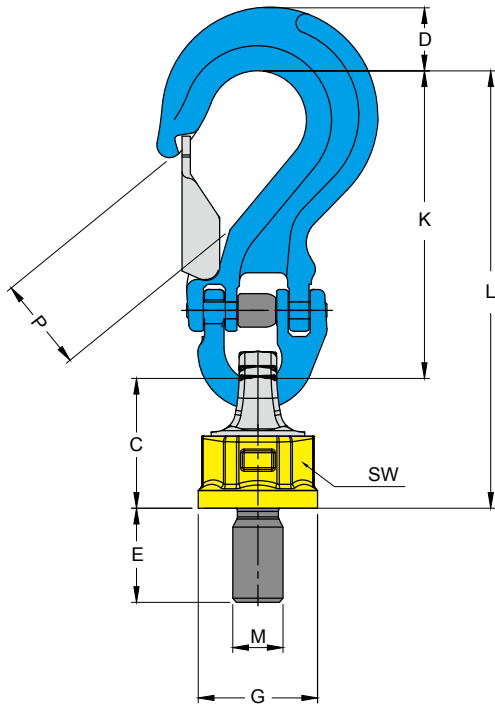

- Rotates through 360° adjustable in the direction of the load.
- Tested in accordance with EN1677-1.
- Load rated parts are 100% magnaflux crack detected.
- Individual forged parts and cap screw are traceable to Test Certification.
- Proof tested to 2.5 times the WLL.
- Fatigue rated to 1.5 times the WLL.
- Hook connecting to any ring structure quickly and safely without additional fittings required
- Ball bearing for turning/rotating under full load.

Hook Point

UNC Thread (8-2521)

Item No.	Working Load Limit tonnes	Thread version			Dimensions							Torque in		N.W. lbs
		M inch	E inch	Pitch	G	C	K	F inch	D	B	A	Nm		
8-2521-014	1.4	5/8	0.94	11UNC	1.44	1.57	1.34	4.88	0.79	6.45	0.91	45 - 130	1.7	
8-2521-025	2.5	3/4	1.18	10UNC	2.05	2.18	1.81	4.76	0.91	6.94	1.18	100 - 170	3.0	
8-2521-040	4	1	1.42	8UNC	2.24	2.46	1.97	5.87	1.22	8.33	1.42	190 - 280	5.2	
8-2521-067	6.7	1 1/4	1.77	7UNC	2.76	3.07	2.56	7.32	1.42	10.39	1.65	230 - 400	9.2	
8-2521-100	10	1 1/2	2.13	6UNC	3.19	3.38	2.95	8.50	1.77	11.88	1.85	270 - 600	15.1	
8-2521-130	13	1 3/4	2.36	5UNC	4.09	4.09	3.74	9.88	1.89	13.98	2.05	350 - 800	26.6	
8-2521-160	16	2	2.83	4.5UNC	4.09	4.09	3.74	9.88	1.89	13.98	2.05	350 - 800	27.3	

* Proof Load is 2.5 times the Working Load Limit on the 4:1 design factor.



Kind of attachment																				
	Number of legs	Load direction	Item No.	WLL(t)																
8-2521-014	5/8	1.4	2.8	1.4	2.8	2	1.4	1.4	3	2.12	2.12									
8-2521-025	3/4	2.5	5	2.5	5	3.55	2.5	2.5	5.3	3.75	3.75									
8-2521-040	1	4	8	4	8	5.6	4	4	8.5	6	6									
8-2521-067	1 1/4	6.7	13.4	6.7	13.4	9.5	6.7	6.7	14	10	10									
8-2521-100	1 1/2	10	20	10	20	14	10	10	21.2	15	15									
8-2521-130	1 3/4	13	26	13	26	18	13	13	27	19	19									
8-2521-160	2	16	32	16	32	22.0	16	16	33	23.5	23.5									

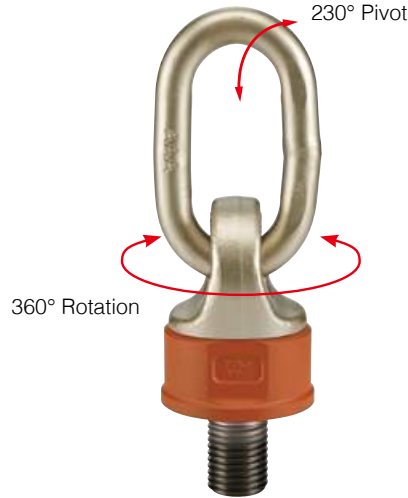
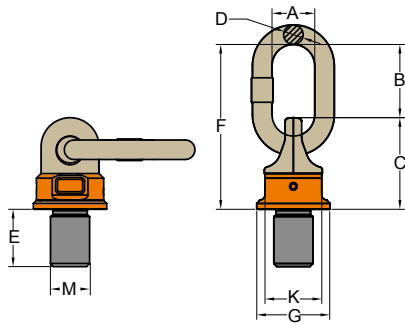

- Pivots more than 230°, rotates through 360° due to its unique ball bearing design. Design factor 4:1 in all directions.
- Manufactured from forged alloy steel, quenched and tempered.
- Manufactured and tested in accordance with EN1677-1 and DNVGL-ST-0378.
- Load rated parts are 100% magnaflux crack detected.
- Individual forged parts and cap screw are traceable to Test Certification.
- Proof tested to 2.5 times the WLL.
- Fatigue rated to 1.5 times the WLL.
- All YOKE Lifting points meet or exceed all the requirements of ASME B30.26.
- Easy to attach or dismantle due to the forged hexagon shaped body of the DA Swivel Point.
- Maximum WLL in axial direction when load ring is aligned.
- Capable of rotating under load. Do not turn continuously in 90 degree direction at full load.

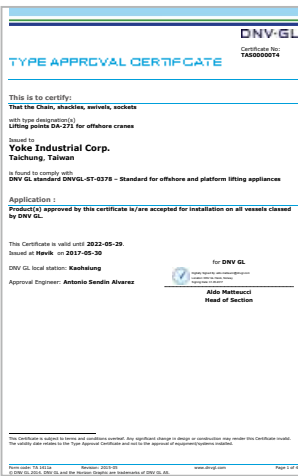

-40°C

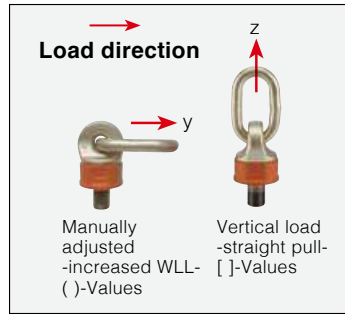

DA Swivel Point

Metric Thread (DA-271)

DNVGL-ST-0378
(Offshore crane- Lifting Appliance)



Item No.	Working Load Limit		Thread version			Dimensions (mm)							Torque		N.W.
	(y)	[z]	M	E	Pitch	G	C	K	F	D	B	A	in	kg	
	tonnes		mm	mm	DIN13				mm						
DA-271-003	0.4	0.6	M 8	12	1.25	35	40	30	72	8	32	29	10 - 40	0.2	
DA-271-004	0.6	0.9	M 10	15	1.5	35	40	30	72	8	32	29	10 - 40	0.2	
DA-271-006	0.7	1.2	M 12	18	1.75	40	45	36	95	10	50	35	15 - 40	0.3	
DA-271-013	1.5	2.6	M 16	24	2	46	54	41	104	13	50	38	45 - 130	0.5	
DA-271-020	2.5	4	M 20	30	2.5	62	68	55	122	13	54	38	100 - 170	1.0	
DA-271-035	4	7	M 24	36	3	78	88	70	154	19	66	40	190 - 280	2.2	
DA-271-060	6	10	M 30	46	3.5	90	120	80	206	22	86	50	270 - 600	4.5	
DA-271-080	10	15	M 36	55	4	90	120	80	206	22	86	50	270 - 600	4.6	
DA-271-120	13	17	M 42	64	4.5	98	122	84	235	25	110	65	350 - 800	5.5	
DA-271-130	14	18	M 48	73	5	98	122	84	235	25	110	65	350 - 800	6.1	
DA-271-140	20	25	M 52	79	5	120	150	94	270	32	120	70	350 - 900	10.5	
DA-271-160	20	28	M 56	85	5.5	120	150	94	270	32	120	70	350 - 900	10.7	
DA-271-161	20	28	M 64	95	6	120	150	94	270	32	120	70	500 - 1000	11.6	

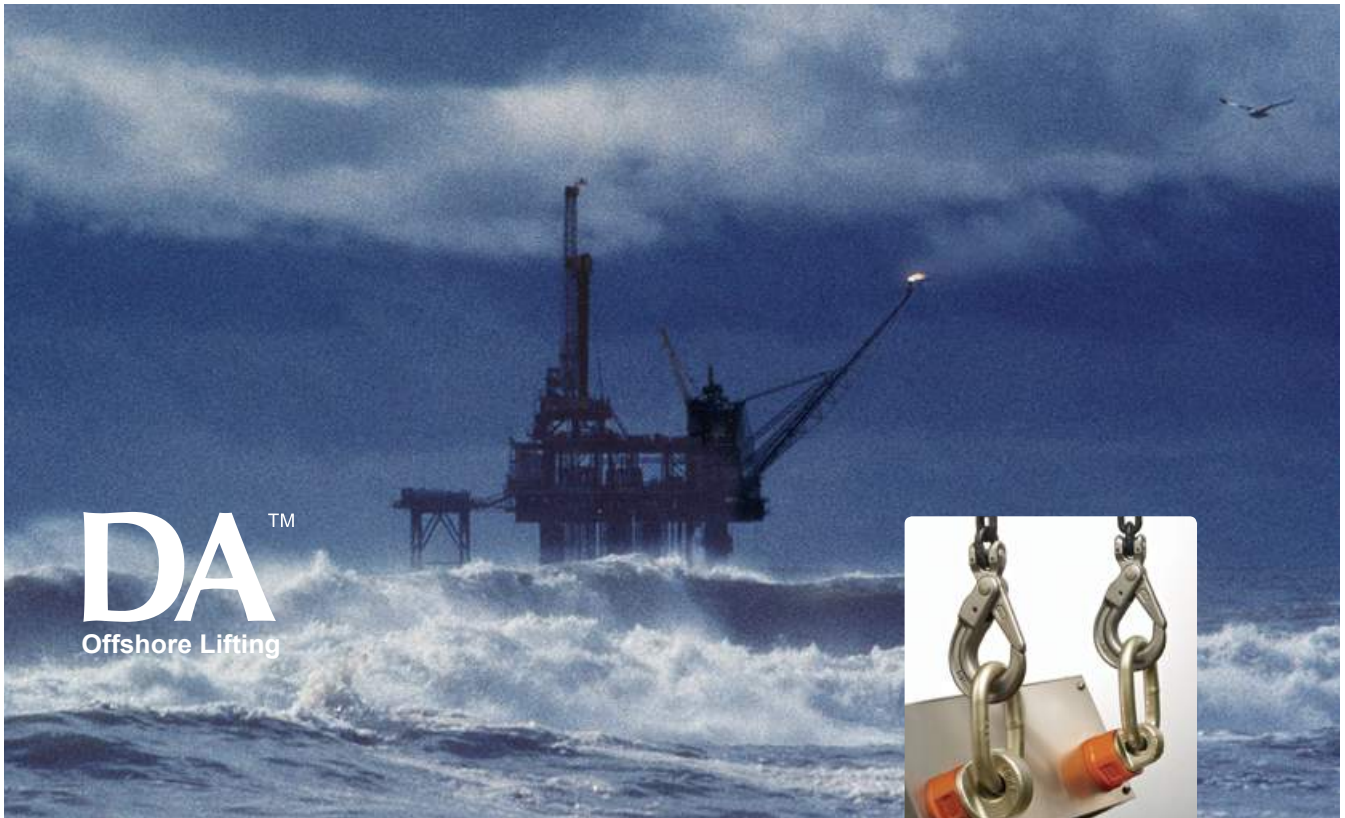

DA™
Offshore Lifting



-40°C

Kind of attachment											
Number of legs		1	2	1	2	2	2	2	3-4	3-4	3-4
Load direction		0°	0°	90°	90°	0-45°	45° - 60°	unsymm.	0 - 45°	45° - 60°	unsymm.
Item No.	Thread	WLL(t)									
DA-271-003	M 8	0.6	1.2	0.4	0.8	0.4	0.3	0.3	0.6	0.4	0.3
DA-271-004	M10	0.9	1.8	0.6	1.2	0.6	0.4	0.4	0.9	0.6	0.4
DA-271-006	M12	1.2	2.4	0.7	1.5	0.8	0.6	0.6	1.2	0.9	0.6
DA-271-013	M16	2.6	5.2	1.5	3	1.8	1.3	1.3	2.7	1.9	1.3
DA-271-020	M20	4	8	2.5	5	2.8	2	2	4.2	3	2
DA-271-035	M24	7	14	4	8	4.9	3.5	3.5	7.3	5.2	3.5
DA-271-060	M30	10	20	6	12	7	5	5	10.5	7.5	5
DA-271-080	M36	15	30	10	20	14	10	10	21	15	10
DA-271-120	M42	17	34	13	26	18.2	13	13	27.3	19.5	13
DA-271-130	M48	18	36	14	28	19.6	14	14	29.4	21	14
DA-271-140	M52	25	50	20	40	28	20	20	42	30	20
DA-271-160	M56	28	56	20	40	28	20	20	42	30	20
DA-271-161	M64	28	56	20	40	28	20	20	42	30	20

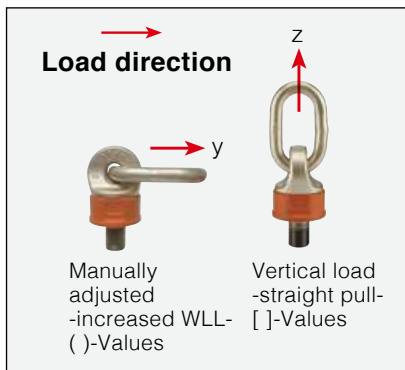
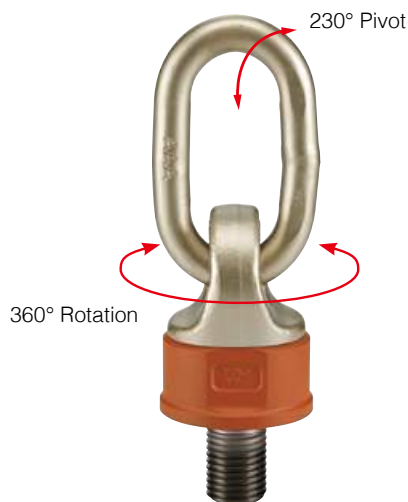
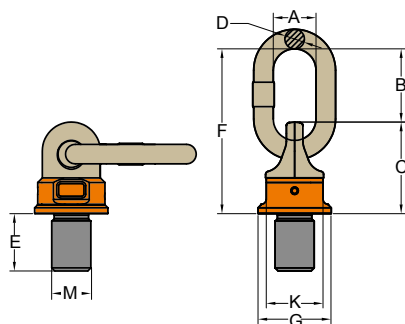

- Pivots more than 230°, rotates through 360° due to its unique ball bearing design. Design factor 4:1 in all directions.
- Manufactured from forged alloy steel, quenched and tempered.
- Manufactured and tested in accordance with EN1677-1 and DNVGL-ST-0378.
- Load rated parts are 100% magnaflux crack detected.
- Individual forged parts and cap screw are traceable to Test Certification.
- Proof tested to 2.5 times the WLL.
- Fatigue rated to 1.5 times the WLL.
- All YOKE Lifting points meet or exceed all the requirements of ASME B30.26.
- Easy to attach or dismantle due to the forged hexagon shaped body of the DA Swivel Point.
- Maximum WLL in axial direction when load ring is aligned.
- Capable of rotating under load. Do not turn continuously in 90 degree direction at full load.

DA Swivel Point

UNC Thread (DA-272)

Item No.	Working Load Limit		Thread version			Dimensions (inch)							Torque	N.W.
	(y)	[z]	M	E	TPI	G	C	K	F	D	B	A	in	
	tonnes		inch	inch					inch				Nm	
DA-272-006	0.7	1.2	1/2	0.75	13UNC	1.57	1.77	1.42	3.74	0.39	1.97	1.38	15 - 40	0.7
DA-272-013	1.5	2.6	5/8	0.94	11UNC	1.81	2.13	1.61	4.09	0.51	1.97	1.50	45 - 130	1.2
DA-272-018	2	3.6	3/4	1.13	10UNC	1.81	2.68	1.61	4.09	0.51	1.97	1.50	45 - 130	1.2
DA-272-020	2.5	4	7/8	1.31	9UNC	2.44	2.68	2.17	4.80	0.51	2.13	1.50	100 - 170	2.2
DA-272-035	4	7	1	1.50	8UNC	3.07	3.46	2.76	6.06	0.75	2.60	1.57	190 - 280	4.8
DA-272-060	6	10	1 1/4	1.88	7UNC	3.54	4.72	3.15	8.11	0.87	3.39	1.97	270 - 600	9.9
DA-272-080	10	15	1 1/2	2.25	6UNC	3.54	4.72	3.15	8.11	0.87	3.39	1.97	270 - 600	10
DA-272-120	13	17	1 3/4	2.63	5UNC	3.86	4.80	3.31	9.25	0.98	4.33	2.56	350 - 800	12.1
DA-272-130	14	18	2	3.00	4.5UNC	3.86	4.80	3.31	9.25	0.98	4.33	2.56	350 - 800	13.5
DA-272-140	20	25	2 1/4	3.38	4.5UNC	4.72	5.91	3.70	10.63	1.26	4.72	2.76	350 - 900	23.1
DA-272-160	20	28	2 1/2	3.75	4UNC	4.72	5.91	3.70	10.63	1.26	4.72	2.76	350 - 900	23.5



DA™
Offshore Lifting

-40°C



Kind of attachment											
Number of legs	Load direction	1	2	1	2	2	2	2	3-4	3-4	3-4
Item No.	Thread	0°	0°	90°	90°	0-45°	45° - 60°	unsymm.	0 - 45°	45° - 60°	unsymm.
		WLL(t)									
DA-272-006	1/2	1.2	2.4	0.7	1.5	0.8	0.6	0.6	1.2	0.9	0.6
DA-272-013	5/8	2.6	5.2	1.5	3	1.8	1.3	1.3	2.7	1.9	1.3
DA-272-018	3/4	3.6	7.2	2	4	2.5	1.8	1.8	3.7	2.7	1.8
DA-272-020	7/8	4	8	2.5	5	2.8	2	2	4.2	3	2
DA-272-035	1	7	14	4	8	4.9	3.5	3.5	7.3	5.2	3.5
DA-272-060	1 1/4	10	20	6	12	7	5	5	10.5	7.5	5
DA-272-080	1 1/2	15	30	10	20	14	10	10	21	15	10
DA-272-120	1 3/4	17	34	13	26	18.2	13	13	27.3	19.5	13
DA-272-130	2	18	36	14	28	19.6	14	14	29.4	21	14
DA-272-140	2 1/4	25	50	20	40	28	20	20	42	30	20
DA-272-160	2 1/2	28	56	20	40	28	20	20	42	30	20

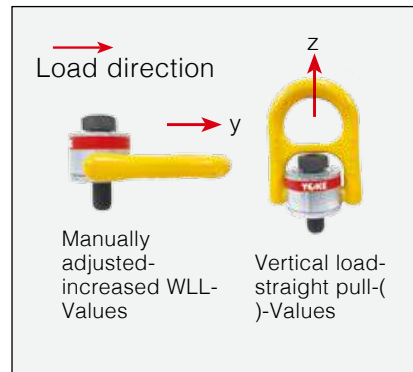
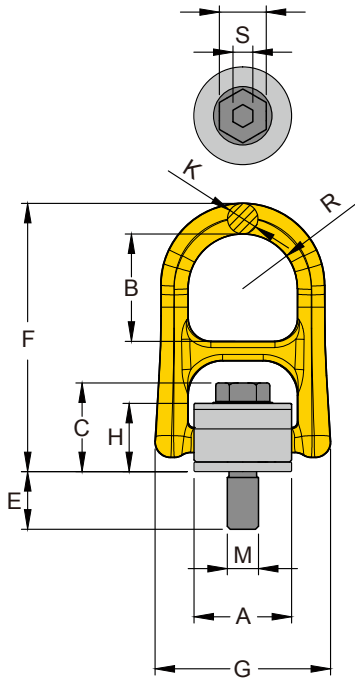

- Rotates through 360° and pivot 180°, rated at 100% at 90°angle.
- Manufactured from forged alloy steel, quenched and tempered.
- Manufactured and tested in accordance with EN1677-1.
- Load rated parts are 100% magnaflux crack detected.
- Individual forged parts and cap screw are traceable to Test Certification.
- Bolt are Metric thread (ASME / ANSI B18.3.1M).
- Proof tested to 2.5 times the WLL.
- Fatigue rated to 1.5 times the WLL.
- All YOKE Lifting points meet or exceed all the requirements of ASME B30.26.
- Quick and simple assembly, just a tapped hole is required.
- Red label is for metric thread.

» Taiwan Patent
» China Patent

ExtreME Hoist Ring

Metric Thread (8-241)



Item No.	Working Load Limit		Thread version			Dimensions										Torque in		N.W.
	y	(z)	M	E	Pitch	A	B	C	D	F	G	H	R	S	SW	Nm	kg	
	tonnes		mm	mm	DIN13				mm									
8-241-005	0.5	0.8	M 8	12	1.25	33	35	28	11	80	58	23	17	6	13	30	0.3	
8-241-007	0.7	1.2	M 10	15	1.5	33	35	29	11	80	58	23	17	6	17	60	0.3	
8-241-010	1.0	2.0	M 12	20	1.75	33	35	31	11	80	58	23	17	8	19	100	0.3	
8-241-020	2.0	3.2	M 16	24	2	50	55	46	17	117	90	36	27	10	24	150	0.8	
8-241-030	3.0	5.6	M 20	30	2.5	50	55	49	17	117	90	36	27	12	30	250	0.9	
8-241-050	5.0	9.2	M 24	36	3	72	66	59	25	163	125	44	37	14	36	400	2.7	
8-241-078	7.8	12.0	M 30	48	3.5	87	72	81	30	204	148	62	46	17	46	500	5.5	
8-241-125	12.5	14.0	M 36	54	4	110	80	98	36	247	188	75	57	22	55	1000	8.6	
8-241-156	15.6	16.0	M 42	63	4.5	110	100	108	36	247	188	83	57	24	65	1500	13	
8-241-200	20.0	20.0	M 48	72	5	110	100	113	36	248	188	83	57	27	75	2000	14	

* Proof Load is 2.5 times the Working Load Limit on the 4:1 design factor.
* Bolt in GEOMET® finished on request



Kind of attachment

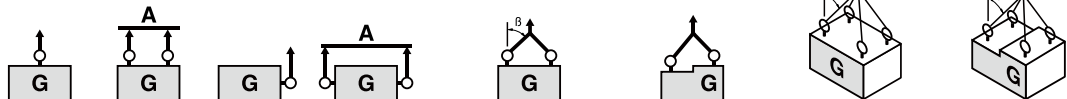

Number of legs	1		2		2		2		3-4		3-4	
	0°	90°	0°	90°	0-45°	45°- 60°	unsymm.	0 - 45°	45°- 60°	unsymm.	0 - 45°	45°- 60°
Item No.	Thread		WLL(t)									
8-241-005	M 8	0.8	1.6	0.5	1	0.7	0.5	0.5	1.1	0.8	0.5	
8-241-007	M10	1.2	2.4	0.7	1.4	1	0.7	0.7	1.5	1.1	0.7	
8-241-010	M12	2	4	1	2	1.4	1	1	2.1	1.5	1	
8-241-020	M16	3.2	6.4	2	4	2.8	2	2	4.2	3	2	
8-241-030	M20	5.6	11.2	3	6	4.2	3	3	6.3	4.5	3	
8-241-050	M24	9.2	18.4	5	10	7	5	5	10.5	7.5	5	
8-241-078	M30	12	24	7.8	15.6	10.9	7.8	7.8	16.4	11.7	7.8	
8-241-125	M36	14	28	12.5	25	17.5	12.5	12.5	26.3	18.8	12.5	
8-241-156	M42	16	32	15.6	31.2	21.8	15.6	15.6	32.8	23.4	15.6	
8-241-200	M48	20	40	20	40	28	20	20	42	30	20	

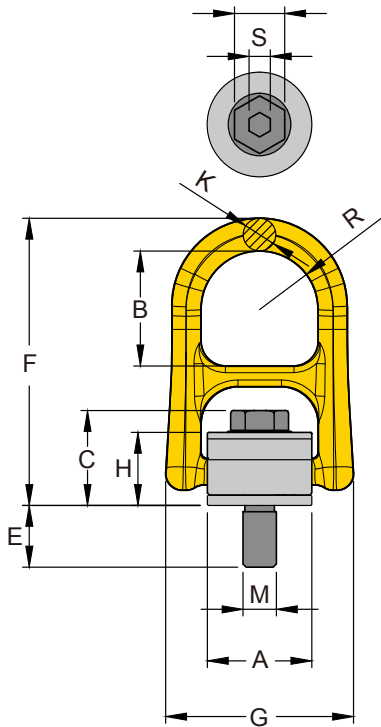

- Rotates through 360° and pivot 180°, rated at 100% at 90° angle.
- Manufactured from forged alloy steel, quenched and tempered.
- Manufactured and tested in accordance with EN1677-1.
- Load rated parts are 100% magnaflux crack detected.
- Individual forged parts and cap screw are traceable to Test Certification.
- Bolt are Metric thread (ASME / ANSI B18.3.1M).
- Proof tested to 2.5 times the WLL.
- Fatigue rated to 1.5 times the WLL.
- All YOKE Lifting points meet or exceed all the requirements of ASME B30.26.
- Quick and simple assembly, just a tapped hole is required.
- Blue label is for UNC thread.

» Taiwan Patent
» China Patent

Extre^me Hoist Ring

UNC Thread (8-242)



Item No.	Working Load Limit		Thread version			Dimensions										Torque	
	y	(z)	M	E	TPI	A	B	C	D	F	G	H	R	S	SW	in	N.W.
	tonnes		inch	inch					inch							Nm	lbs
8-242-010	0.8	1.6	1/2	0.81	13 UNC	1.3	1.38	1.20	0.41	3.17	2.28	0.90	0.67	5/16	3/4	100	0.7
8-242-020	1.6	2.6	5/8	1.13	11 UNC	1.97	2.17	1.81	0.65	4.61	3.54	1.42	1.06	3/8	15/16	150	1.8
8-242-030	2.4	4.0	3/4	1.54	10 UNC	1.97	2.17	1.89	0.65	4.61	3.54	1.42	1.06	1/2	1 1/8	250	2.0
8-242-038	3.0	4.5	7/8	1.42	9 UNC	2.56	2.60	2.28	0.79	6.02	4.25	1.73	1.34	5/8	15/16	300	5.9
8-242-050	4.0	7.4	1	1.61	8 UNC	2.81	2.60	2.34	0.98	6.38	4.92	1.73	1.46	5/8	1 1/2	400	12.1
8-242-078	6.25	9.6	1 1/4	2.09	7 UNC	3.43	3.15	2.23	1.18	8.07	5.83	2.44	1.79	7/8	1 7/8	500	18.9
8-242-125	10.0	11.0	1 1/2	2.40	6 UNC	4.29	3.94	3.87	1.42	9.92	7.40	3.07	2.22	1	2 1/4	800	28.6
8-242-200	16.0	16.0	2	3.00	4.5 UNC	4.61	3.94	4.46	1.42	9.93	7.71	3.35	2.38	1 1/4	3	2000	30.8

* Proof Load is 2.5 times the Working Load Limit on the 5:1 design factor.
* Bolt in GEOMET[®] finished on request



Kind of attachment

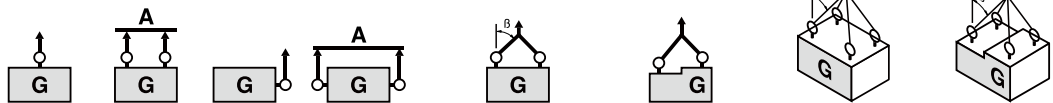

Number of legs	Thread	WLL(t)									
		1	2	1	2	2	2	2	3-4	3-4	3-4
Load direction		0°	0°	90°	90°	0-45°	45°- 60°	unsymm.	0 - 45°	45°- 60°	unsymm.
Item No.	Thread										
8-242-010	1/2	1.6	3.2	0.8	1.6	1.12	0.8	0.8	1.68	1.2	0.8
8-242-020	5/8	2.6	5.2	1.6	3.2	2.24	1.6	1.6	3.36	2.4	1.6
8-242-030	3/4	4	8	2.4	4.8	3.36	2.4	2.4	5.04	3.6	2.4
8-242-038	7/8	4.5	9	3	6	4.2	3	3	6.3	4.5	3
8-242-050	1	7.4	14.8	4	8	5.6	4	4	8.4	6	4
8-242-078	1 1/4	9.6	19.2	6.25	12.5	8.75	6.25	6.25	13.13	9.38	6.25
8-242-125	1 1/2	11	22	10	20	14	10	10	21	15	10
8-242-200	2	16	32	16	32	22.4	16	16	33.6	24	16

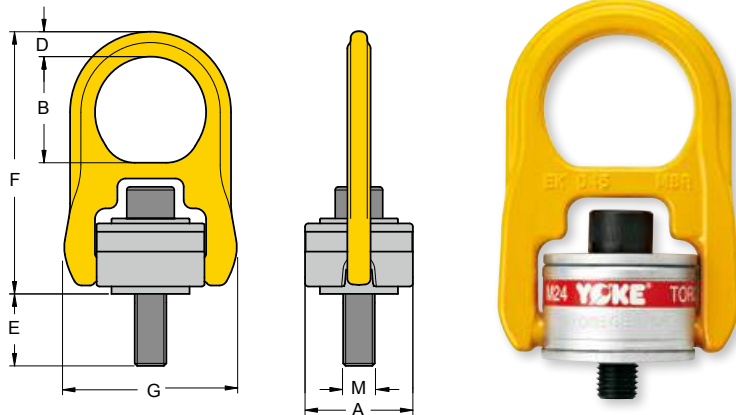

- Rotates through 360° and pivot 180°, rated at 100% at 90° angle.
- Manufactured from forged alloy steel, quenched and tempered.
- Manufactured and tested in accordance with EN1677-1.
- Load rated parts are 100% magnaflux crack detected.
- Individual forged parts and cap screw are traceable to Test Certification.
- Bolt are Metric thread (ASME / ANSI B18.3.1M).
- Individually proof tested to 2.5 times the WLL.
- Fatigue rated to 1.5 times the WLL.
- All YOKE Lifting points meet or exceed all the requirements of ASME B30.26.
- Quick and simple assembly, just a tapped hole is required.

» Taiwan Patent
» China Patent

Hoist Ring

with Alloy Steel Washer
Metric Thread (8-203)

Item No.	Working Load Limit		Thread	Dimensions (mm)						Torque in		N.W.	
	tonnes*			M	A	B	D	E	F	G	Nm		kg
	5 : 1	4 : 1											
8-203-004	0.40	0.50	M 8 x 1.25	40	41	9	17	102	65	10	0.4		
8-203-005	0.45	0.55	M10 x 1.5	40	41	9	11	102	65	16	0.5		
§ 8-203-005L	0.45	0.55	M10 x 1.5	40	41	9	26	102	65	16	0.5		
§ 8-203-010	1.05	1.30	M12 x 1.75	65	64	15	15	158	105	38	1.7		
§ 8-203-010L	1.05	1.30	M12 x 1.75	65	64	15	30	158	105	38	1.7		
§ 8-203-019	1.90	2.40	M16 x 2	65	64	15	20	158	105	81	1.8		
§ 8-203-019L	1.90	2.40	M16 x 2	65	64	15	35	158	105	81	1.8		
§ 8-203-021	2.15	2.70	M20 x 2.5	65	64	15	25	158	105	136	1.8		
§ 8-203-021L	2.15	2.70	M20 x 2.5	65	64	15	45	158	105	136	1.9		
§ 8-203-030	3.00	3.75	M20 x 2.5	85	79	19	25	204	134	136	4.0		
§ 8-203-030L	3.00	3.75	M20 x 2.5	85	79	19	45	204	134	136	5.2		
§ 8-203-042	4.20	5.25	M24 x 3	85	79	19	26	204	134	312	4.2		
§ 8-203-042L	4.20	5.25	M24 x 3	85	79	19	56	204	134	312	4.3		
§ 8-203-070	7.00	8.75	M30 x 3.5	100	100	25	81	241	160	637	6.6		
8-203-110	11.00	13.75	M36 x 4	120	111	30	76	286	194	1005	15.0		
8-203-125	12.50	15.60	M42 x 4.5	120	111	30	65	286	220	1005	16.0		
8-203-135	13.50	16.90	M48 x 5	120	111	30	70	286	220	1350	16.0		
8-203-155	15.50	19.40	M56 x 5.5	138	109	34	79	308	241	1350	19.1		
8-203-223	22.30	27.90	M64 x 6	138	100	38	98	312	241	2847	23.0		

* Proof Load is 2.5 times the Working Load Limit on the 4:1 design factor.

** Bolt in GEOMET® finished on request

§ Long Bolts are designed for soft metal work piece.

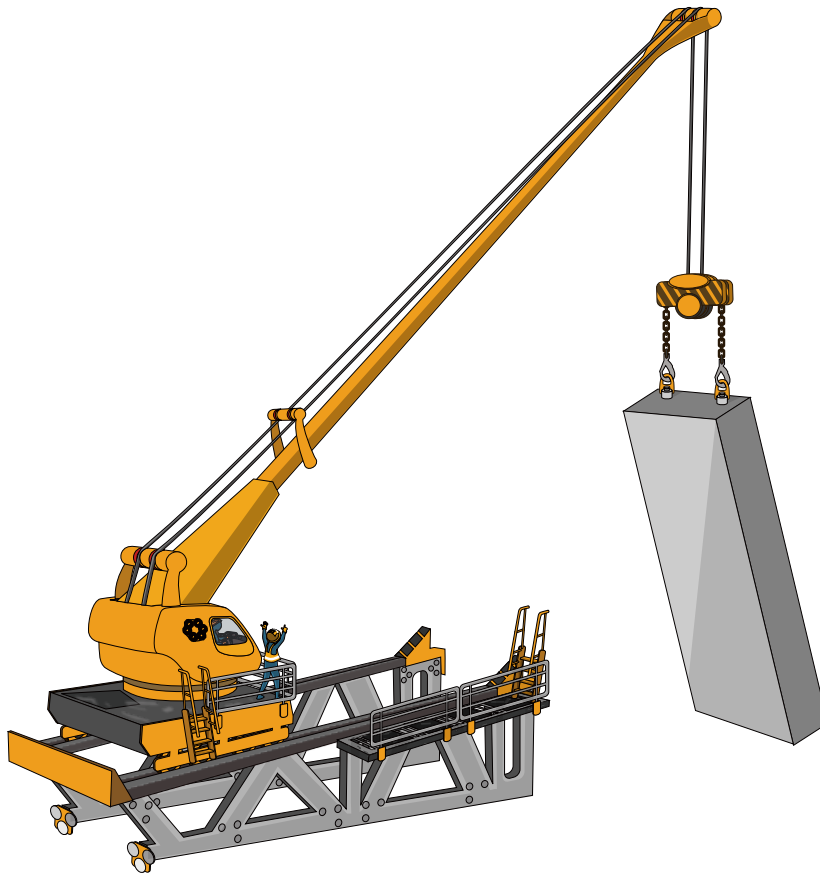

Kind of attachment											
Number of legs		1	2	1	2	2	2	2	3-4	3-4	3-4
Load direction		0°	0°	90°	90°	0-45°	45° - 60°	unsymm.	0 - 45°	45° - 60°	unsymm.
Item No.		WLL(t)									
8-203-004	M 8	0.5	1	0.5	1	0.7	0.5	0.5	1.05	0.75	0.5
8-203-005	M10	0.55	1.1	0.55	1.1	0.77	0.55	0.55	1.16	0.83	0.55
8-203-010	M12	1.3	2.6	1.3	2.6	1.82	1.3	1.3	2.73	1.95	1.3
8-203-019	M16	2.4	4.8	2.4	4.8	3.36	2.4	2.4	5.04	3.6	2.4
8-203-021	M20	2.7	5.4	2.7	5.4	3.78	2.7	2.7	5.67	4.05	2.7
8-203-030	M20	3.75	7.5	3.75	7.5	5.25	3.75	3.75	7.88	5.63	3.75
8-203-042	M24	5.25	10.5	5.25	10.5	7.35	5.25	5.25	11.03	7.88	5.25
8-203-070	M30	8.75	17.5	8.75	17.5	12.25	8.75	8.75	18.38	13.13	8.75
8-203-110	M36	13.75	27.5	13.75	27.5	19.25	13.75	13.75	28.88	20.63	13.75
8-203-125	M42	15.6	31.2	15.6	31.2	21.84	15.6	15.6	32.76	23.4	15.6
8-203-135	M48	16.9	33.8	16.9	33.5	23.66	16.9	16.9	35.49	25.35	16.9
8-203-155	M56	19.4	38.8	19.4	38.8	27.16	19.4	19.4	40.74	29.1	19.4
8-203-223	M64	27.9	55.8	27.9	55.8	39.06	27.9	27.9	58.59	41.85	27.9

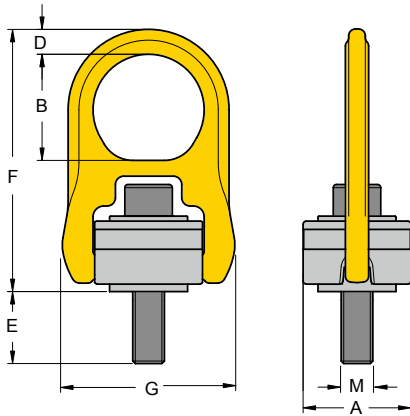

- Rotates through 360° and pivot 180°, rated at 100% at 90° angle.
- Manufactured from forged alloy steel, quenched and tempered.
- Manufactured and tested in accordance with EN1677-1.
- Load rated parts are 100% magnaflux crack detected.
- Individual forged parts and cap screw are traceable to Test Certification.
- Bolt are Metric thread (ASME / ANSI B18.3.1M).
- Individually proof tested to 2.5 times the WLL.
- Fatigue rated to 1.5 times the WLL.
- All YOKE Lifting points meet or exceed all the requirements of ASME B30.26.
- Quick and simple assembly, just a tapped hole is required.

» Taiwan Patent
» China Patent

Hoist Ring

with Alloy Steel Washer

UNC Thread (8-204)

Item No.	Working Load Limit	Thread	Dimensions (inch)						Torque in	N.W.
	lbs*		TPI	A	B	D	E	F	G	ft.lbs
8-204-004	800	5/16 - 18UNC	1.57	1.61	0.35	0.71	4.02	2.56	10	0.9
8-204-005	1000	3/8 - 16UNC	1.57	1.61	0.35	0.71	4.02	2.56	16	0.9
§ 8-204-010	2500	1/2 - 13UNC	2.56	2.32	0.59	0.75	6.26	4.13	16	3.7
8-204-010L	2500	1/2 - 13UNC	2.56	2.32	0.59	1.26	6.26	4.13	38	3.7
§ 8-204-019	4000	5/8 - 11UNC	2.56	2.32	0.59	0.74	6.26	4.13	38	4.0
8-204-019L	4000	5/8 - 11UNC	2.56	2.32	0.59	1.75	6.26	4.13	81	4.0
§ 8-204-021	5000	3/4 - 10UNC	2.56	2.87	0.59	1.24	6.26	4.13	81	4.0
8-204-021L	5000	3/4 - 10UNC	2.56	2.87	0.59	1.73	6.26	4.13	136	4.2
§ 8-204-030	7000	3/4 - 10UNC	3.35	2.87	0.59	0.87	6.26	5.28	136	8.8
8-204-030L	7000	3/4 - 10UNC	3.35	2.87	0.87	1.87	8.03	5.28	136	9.5
§ 8-204-042	8000	7/8 - 9UNC	3.35	2.87	0.87	1.43	8.03	5.28	136	9.3
8-204-042L	8000	7/8 - 9UNC	3.35	2.87	0.87	2.37	8.03	5.28	312	9.7
§ 8-204-045	10000	1 - 8UNC	3.35	2.87	0.87	1.36	8.03	5.28	312	9.5
8-204-045L	10000	1 - 8UNC	3.35	2.87	0.87	2.36	8.03	5.28	637	10.1
8-204-070	15000	1 1/4 - 7UNC	3.95	3.15	1.00	2.25	8.58	6.30	1005	14.5
8-204-125	24000	1 1/2 - 6UNC	4.72	4.29	1.38	2.17	12.09	8.66	1005	35.2
8-204-135	30000	2 - 4.5UNC	4.72	4.29	1.38	3.01	12.09	8.66	1350	35.2

★ Design Factor 5:1
§ Long Bolts are designed for soft metal work piece.
** Bolt in GEOMET® finished on request

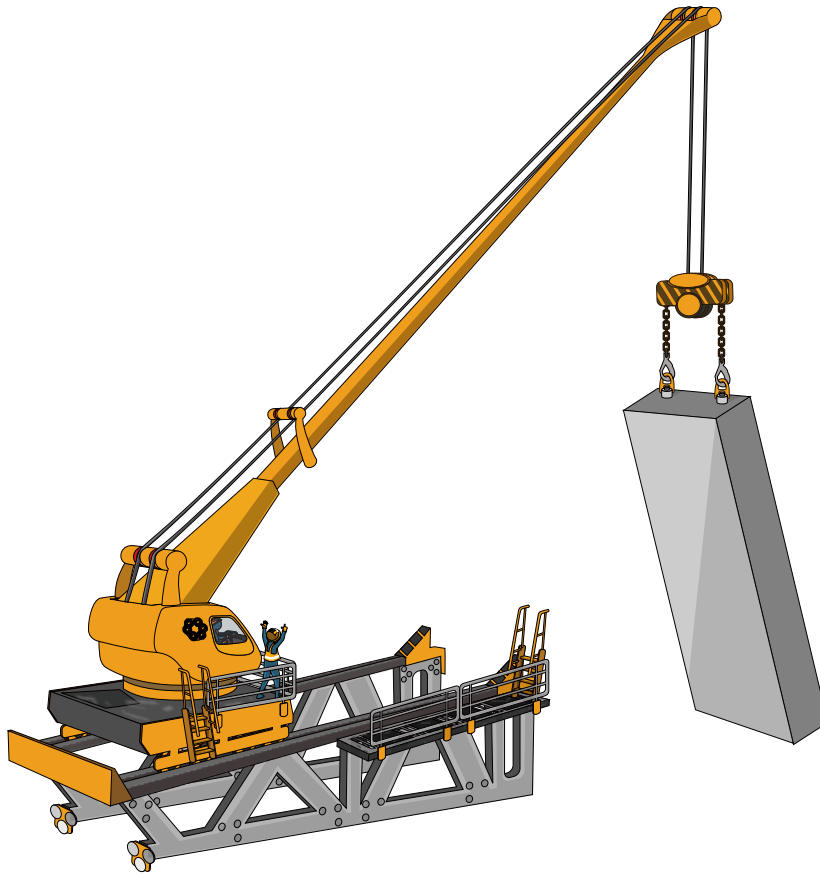

Kind of attachment																
	Number of legs	Load direction	1	2	1	2	2	2	2	3-4	3-4	3-4	3-4	3-4	3-4	
Item No.		0°	0°	90°	90°	0-45°	45° - 60°	unsymm.	0 - 45°	45° - 60°	unsymm.	0 - 45°	45° - 60°	unsymm.		
		WLL(t)														
8-204-004	5/16	0.36	0.72	0.36	0.72	0.504	0.36	0.36	0.756	0.54	0.36					
8-204-005	3/8	0.45	0.9	0.45	0.9	0.63	0.45	0.45	0.945	0.675	0.45					
8-204-010	1/2	1.1	2.2	1.1	2.2	1.54	1.1	1.1	2.31	1.65	1.1					
8-204-019	5/8	1.8	3.6	1.8	3.6	2.52	1.8	1.8	3.78	2.7	1.8					
8-204-021	3/4	2.2	4.4	2.2	4.4	3.08	2.2	2.2	4.62	3.3	2.2					
8-204-030	3/4	3.1	6.2	3.1	6.2	4.34	3.1	3.1	6.51	4.65	3.1					
8-204-042	7/8	3.6	7.2	3.6	7.2	5.04	3.6	3.6	7.56	5.4	3.6					
8-204-045	1	4.5	9	4.5	9	6.3	4.5	4.5	9.45	6.75	4.5					
8-204-070	1 1/4	6.8	13.6	6.8	13.6	9.52	6.8	6.8	14.28	10.2	6.8					
8-204-125	1 1/2	10.9	21.8	10.9	21.8	15.26	10.9	10.9	22.89	16.35	10.9					
8-204-135	2	13.6	27.2	13.6	27.2	19.04	13.6	13.6	28.56	20.4	13.6					



Y PSA

Anchor Point for Personal Protective Equipment



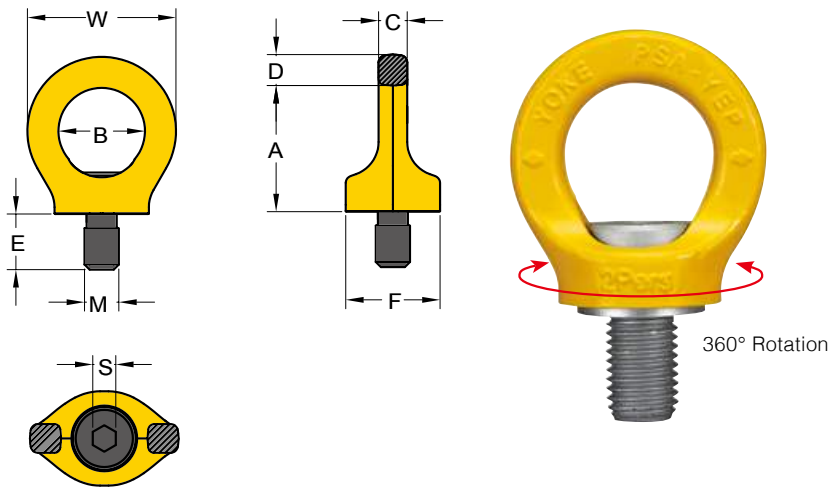

Anchor Point for Personal Protective Equipment

- PSA - Lifting point to be as an anchor point for personal protective equipment.
- Rotates through 360°
- Manufactured from forged alloy steel, quenched and tempered.
- Load rated parts are 100% magnaflux crack detected.
- Passed 22.2 KN/person Load testing.
- Passed 150 kg dynamic fall testing (EU standard is 100 kg).
- Meets all requirements of the German BG BAU (Employer’s insurance association of the building industry).
- Meets all requirements of DIN EN795, DIN EN50308, OSHA1926.502.
- Acc. to DIN EN 365 including statement for the number of load bearing persons is 1-2 persons.
- Correspond to the European Directive for “personnel protection equipment” (89/686/ EWG).
- YOKE yellow powder coating for high visibility.

- » China Patent
- » French Patent
- » Australian Patent
- » Japanese Patent

PSA-YEP

Metric Thread (8-281)

Item No.	Working Load Limit	Thread version	Dimensions (mm)								Torque in		N.W.
			M	A	B	C	D	E	F	S	W	Nm	
8-281-007	1 Pers	M12 x 1.75	45	30	10	11	19	33	8	52	10	0.2	
8-281-015	2 Pers	M16 x 2	52	35	14	13	24	35	10	61	30	0.3	
8-281-023	2 Pers	M20 x 2.5	60	40	16	15	30	44	12	70	70	0.6	

PSA-YEP

UNC Thread (8-281)

Item No.	Working Load Limit	Thread version	Dimensions (inch)								Torque in		N.W.
			M	A	B	C	D	E	F	S	W	ft. lbs	
8-281-007	1 Pers	M12 x 1.75	1.8	1.2	0.4	0.4	0.7	1.3	0.3	2.0	7.4	0.4	
8-281-015	2 Pers	M16 x 2	2.0	1.4	0.6	0.5	0.9	1.4	0.4	2.4	22.1	0.7	
8-281-023	2 Pers	M20 x 2.5	2.4	1.6	0.6	0.6	1.2	1.7	0.5	2.8	51.7	1.3	

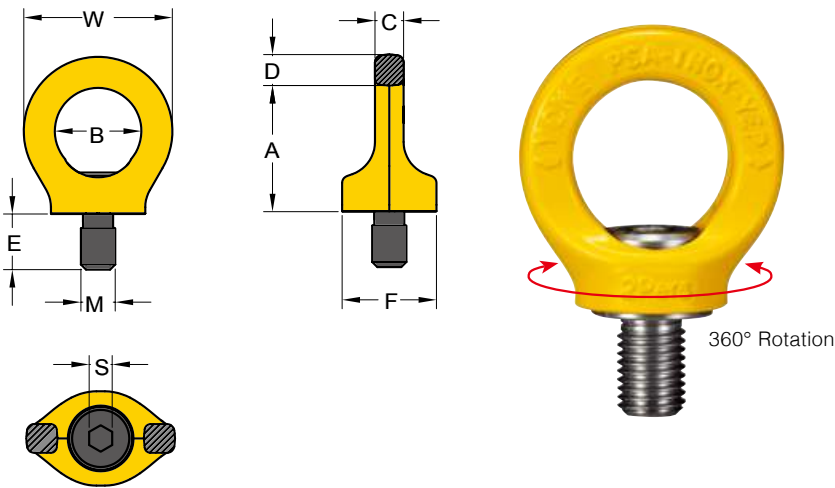

- PSA-INOX Lifting point to be as an anchor point for personal protective equipment.
- Rotates 360°.
- Manufactured from forged stainless steel.
- Load rated parts are 100% magnaflux crack detected.
- Passed 22.2KN/person load testing.
- Passed 150 kg dynamic fall testing (EU standard is 100 kg).
- Meets all requirements of the German BG BAU (Employer's insurance association of the building industry).
- Meets all requirements of DIN EN795, DIN EN50308, OSHA1926.502.
- Acc. to DIN EN 365 including statement for the number of load bearing persons is 1-2 persons.
- Corresponds to the European Directive for "personnel protection equipment" (89/686/EWG).
- YOKE yellow powder coating for high visibility.
- Suitable for permanently outdoor application.

- » China Patent
- » French Patent
- » Australian Patent
- » Japanese Patent



Anchor Point for Personal Protective Equipment

PSA-INOX-YEP

Metric Thread (8-285) stainless steel

Item No.	Working Load Limit	Thread version	Dimensions (mm)								Torque	
			M	A	B	C	D	E	F	S	W	Nm
8-285-007	1 Pers	M12 x 1.75	45	30	10	11	19	33	8	52	10	0.2
8-285-015	2 Pers	M16 x 2	52	35	14	13	24	35	10	61	30	0.3
8-285-023	2 Pers	M20 x 2.5	60	40	16	15	30	44	12	70	70	0.6

PSA-INOX-YEP

UNC Thread (8-285) stainless steel

Item No.	Working Load Limit	Thread version	Dimensions (inch)								Torque	
			M	A	B	C	D	E	F	S	W	ft. lbs
8-285-007	1 Pers	M12x1.75	1.8	1.2	0.4	0.4	0.7	1.3	0.3	2.0	7.4	0.4
8-285-015	2 Pers	M16x2	2.0	1.4	0.6	0.5	0.9	1.4	0.4	2.4	22.1	0.7
8-285-023	2 Pers	M20x2.5	2.4	1.6	0.6	0.6	1.2	1.7	0.5	2.8	51.7	1.3

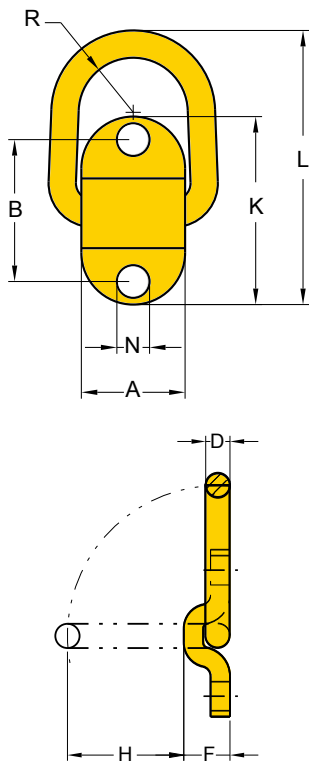

- Pivots 180° side loading allowed.
- Manufactured from forged alloy steel, quenched and tempered.
- Manufactured and tested in accordance with EN1677-1.
- Load rated parts are 100% magnaflux crack detected.
- Individual forged parts are traceable to Test Certification.
- Supplied without bolts; usage of Grade 10.9 or Grade 12.9 bolts is recommended.
- Individually proof tested to 2.5 times the WLL.
- Fatigue rated to 1.5 times the WLL.
- All YOKE Lifting points meet or exceed all the requirements of ASME B30.26.

Bolt-on Tie Down. Code“DAB”.

Designed with spring, stop at any angle supplied without bolt (Metric Thread8-058)

Item No.	Working Load Limit	Dimensions (mm)										N.W.
		A	B	D	F	H	K	L	N	R	kg	
8-058-1T	1.0	50	72	14	27	55	98	139	14	24	0.7	
8-058-3T	3.0	58	84	17	33	50	114	144	18	29	1.1	
8-058-5T	5.0	64	116	22	43	74	160	203	23	33	2.5	

* Design factor 5:1
 * Bolts of grade 10.9 & 12.9 are recommended

Bolt-on Tie Down. Code“DAB”.

Designed with spring, stop at any angle supplied without bolt (UNC Thread 8-058)

Item No.	Working Load Limit	Dimensions (inch)										N.W.
		A	B	D	F	H	K	L	N	R	lbs	
8-058-1T	2200	1.97	2.83	0.55	1.06	2.17	3.86	5.47	0.55	0.94	1.5	
8-058-3T	6600	2.28	3.31	0.67	1.30	1.97	4.49	5.67	0.71	1.14	2.4	
8-058-5T	11000	2.52	4.57	0.87	1.69	2.91	6.30	7.99	0.91	1.30	5.5	

* Design factor 5:1
 * Bolts of grade 10.9 & 12.9 are recommended



Weld-on Lifting Points





Economic Point
8-0573



Weld-on Point
8-057



Weld-on Ring
8-082



Weld-on Hook
8-081

Kind of attachment																				
	Number of legs	Load direction	Number of legs	Load direction	Number of legs	Load direction	Number of legs	Load direction	Number of legs	Load direction	Number of legs	Load direction	Number of legs	Load direction	Number of legs	Load direction	Number of legs	Load direction	Number of legs	Load direction
Item No.	WLL(t)																			
8-0573-01	1	0°	2	0°	1	90°	2	90°	2	0-45°	2	45°-60°	2	unsymm.	3-4	0-45°	3-4	45°-60°	3-4	unsymm.
8-0573-03	3		6		3		6		4.2	3		3		6.3		4.5		3		
8-0573-05	5		10		5		10		7	5		5		10.5		7.5		5		
8-0573-08	8		16		8		16		11.2	8		8		16.8		12		8		
8-0573-10	10		20		10		20		14	10		10		21		15		10		
8-0573-20	20		40		20		40		28	20		20		42		30		20		
8-0573-30	30		60		30		60		42	30		30		63		45		30		
8-057-1T	1		2		1		2		1.4	1		1		2.1		1.5		1		
8-057-3T	3		6		3		6		4.2	3		3		6.3		4.5		3		
8-057-5T	5		10		5		10		7	5		5		10.5		7.5		5		
8-057-8T	8		16		8		16		11.2	8		8		16.8		12		8		
8-057-10T	10		20		10		20		14	10		10		21		15		10		
8-082-04	4		8		4		8		5.6	4		4		8.4		6		4		
8-082-06	6.7		13.4		6.7		13.4		9.4	6.7		6.7		14.1		10.1		6.7		
8-082-10	10		20		10		20		14	10		10		21		15		10		
8-082-16	16		32		16		32		22.4	16		16		33.6		24		16		
8-082-30	31.5		63		31.5		63		44.1	31.5		31.5		66.2		47.3		31.5		
8-081-01	1		2		1		2		1.4	1		1		2.1		1.5		1		
8-081-02	2		4		2		4		2.8	2		2		4.2		3		2		
8-081-03	3		6		3		6		4.2	3		3		6.3		4.5		3		
8-081-04	4		8		4		8		5.6	4		4		8.4		6		4		
8-081-05	5		10		5		10		7	5		5		10.5		7.5		5		
8-081-08	8		16		8		16		11.2	8		8		16.8		12		8		
8-081-10	10		20		10		20		14	10		10		21		15		10		
8-081-15	15		30		15		30		21	15		15		31.5		22.5		15		



WELDING INSTRUCTIONS

The welding should only be carried out by qualified welder according to Standards, e.g. EN 287 or AWS.

Support material

- Material of the welding block is S355J2+N (1.0577+N, St 52-3N, B.S. 4360.50D, AISI 1019 etc.).
- Prior to welding, the contact areas must be free from impurities, oil, paint, rust, scale, etc., for example by grinding. If the surface is at all corroded, all rust must be completely removed from the weld area. Painted surface must be prepared in the same way.
- The steel support member must have a carbon content of no more than 0.40%.
- In ambient temperature of 10°C and below, pre-heating of the weld area prior to welding must be carried out.

Seam welding

- The welds must be sufficiently strong to take the required loads.
- Before starting the final weld pass, clean well the root pass to avoid inclusions.
- The complete welding operation must be carried out continuously so that the parts do not have time to cool.
- Effects of temperature
 - The complete construction can be annealed stress release at <600°C without reduction of WLL.
 - Do not rapidly cool the weld.
- A thorough inspection of the weld should be performed. No cracks, pitting, inclusions, notches or undercuts are allowed. If doubt exists, use a suitable NDT method, such as magnetic particle or liquid penetrant to verify.
- If repair is required, grind out the defect and re-weld using the original qualified procedure.

Welding materials

- Weld materials must have a minimum tensile strength of 70,000 PSI (such as AWS A5.1 E-7018), following the electrode manufacturer's recommendations. Reference information as below:

MIG arc welding:

- Wire diameter 0.8 - 1.2 as per DIN 8559-SG 3, AWS A 5.18.
- Important: do not weld in the open air during bad weather

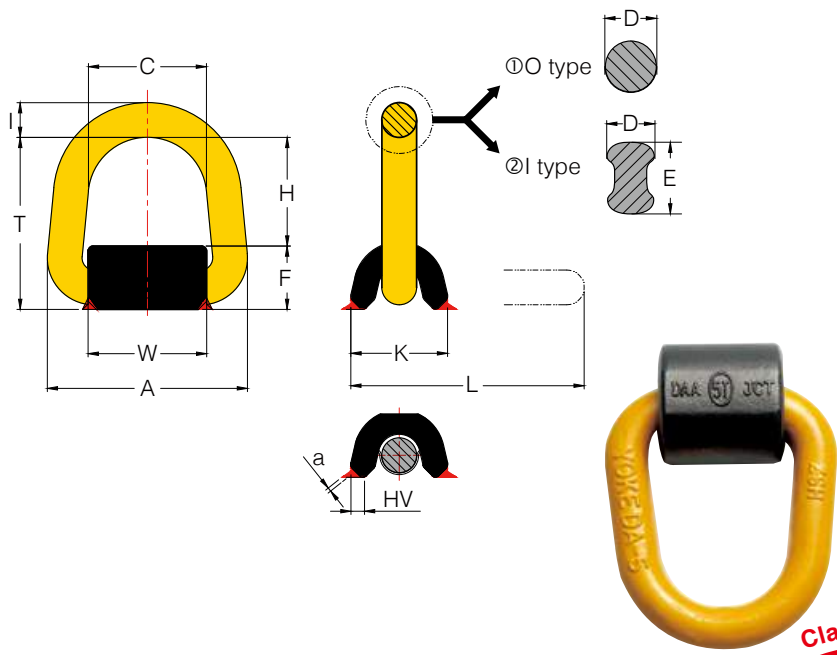

- Pivots through 180°.
- Manufactured from forged alloy steel, quenched and tempered.
- Manufactured and tested in accordance with EN1677-1.
- Load rated parts are 100% magnaflux crack detected.
- Individual forged parts are traceable to Test Certification.
- Proof tested to 2.5 times the WLL.
- Fatigue rated to 1.5 times the WLL.
- All YOKE Lifting points meet or exceed all the requirements of ASME B30.26.
- WLL forged onto each product for quick and easy identification.
- Lugs designed to assist the welding process.

Weld-on Point

without Spring Inside

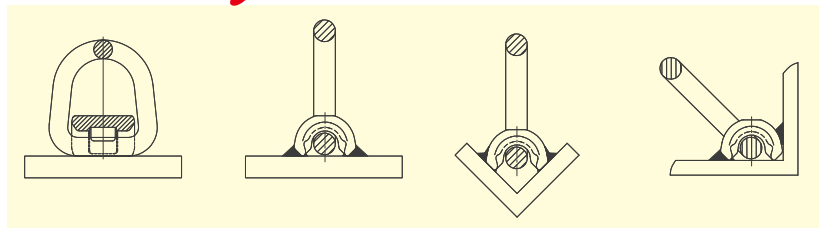

Item No.	Working Load Limit	Dimensions (mm)											N.W.	
		tonnes*	A	C	D	E	F	H	K	L	W	HV		a
①	8-0573-01	1.0	83	48	14	--	26	49	37	105	48	5	3	0.5
	8-0573-03	3.0	98	58	17	--	31	54	48	112	54	6	3	0.9
	8-0573-05	5.0	120	66	22	--	37	55	56	154	56	7	3	1.3
	8-0573-08	8.0	121	68	26	--	47	75	68	169	55	10	4	2.4
②	8-0573-10	10.0	146	82	20	30	47	78	68	191	70	10	4	2.8
	8-0573-20	20.0**	186.5	100	25	37	70	110	93	234	91	20	4	6.5
	8-0573-30	30.0**	254.5	140	35	45	98	127	130	328	127	20	4	17.2

* Design factor 5:1

** Design factor 4:1

Item No.	Working Load Limit	Dimensions (inch)											N.W.	
		lbs*	A	C	D	E	F	H	K	L	W	HV		a
①	8-0573-01	2200	3.27	1.89	0.55	--	1.02	1.93	1.46	4.13	1.89	0.2	0.12	1.1
	8-0573-03	6600	3.86	2.28	0.67	--	1.22	2.13	1.89	4.41	2.13	0.24	0.12	2.0
	8-0573-05	11000	4.72	2.60	0.87	--	1.46	2.17	2.20	6.06	2.20	0.25	0.12	2.9
	8-0573-08	17600	4.76	2.68	1.02	--	1.85	2.95	2.68	6.65	2.17	0.39	0.16	5.3
②	8-0573-10	22000	5.75	3.23	0.79	1.18	1.85	3.07	2.68	7.52	2.76	0.39	0.16	6.2
	8-0573-20	44000**	7.34	3.94	0.98	1.46	2.76	4.33	3.66	9.21	3.58	0.78	0.16	14.3
	8-0573-30	66000**	10.02	5.51	1.38	1.77	3.86	5.00	5.12	12.91	5.00	0.78	0.16	37.8

* Design factor 5:1

** Design factor 4:1

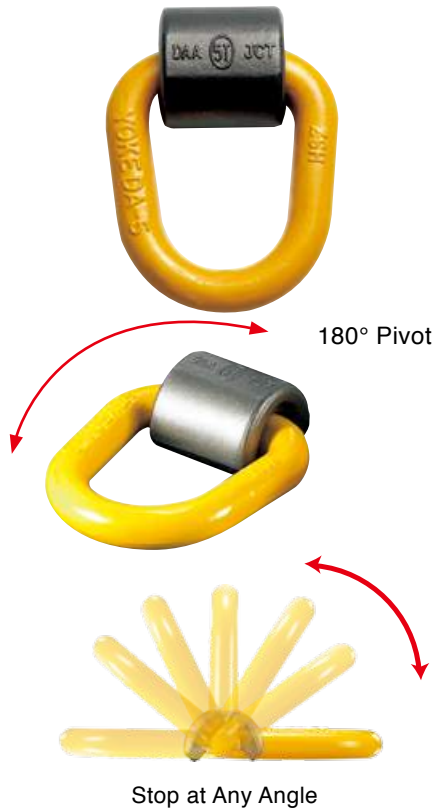
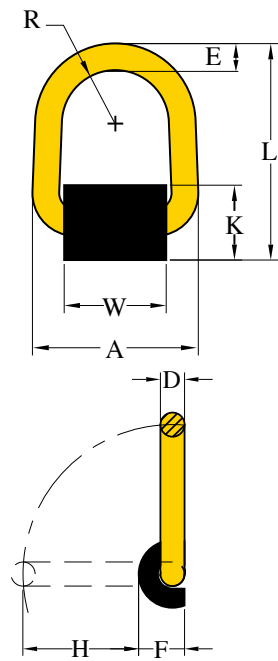

- Pivots through 180°.
- Manufactured from forged alloy steel, quenched and tempered.
- Manufactured and tested in accordance with EN1677-1.
- Load rated parts are 100% magnaflux crack detected.
- Individual forged parts are traceable to Test Certification.
- Proof tested to 2.5 times the WLL.
- Fatigue rated to 1.5 times the WLL.
- All YOKE Lifting points meet or exceed all the requirements of ASME B30.26.
- WLL forged onto each product for quick and easy identification.
- Lugs designed to assist the welding process.
- A protected spring keeps the load ring in a required position. The parts are connected in such a way that they remain captive. The spring also reduces noise caused by vibrations.

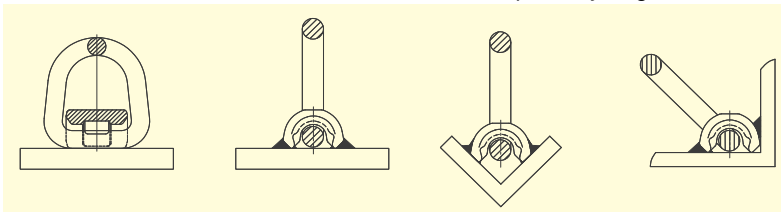

Weld-on Point. Code "DAA".

Designed with spring, stop at any angle

Item No.	Working Load Limit	Dimensions (mm)									N.W.
		tonnes	A	B	D	F	H	K	L	N	
8-057-1T	1.0	83	14	14	27	57	40	109	24	50	0.5
8-057-3T	3.0	98	17	17	31	53	48	114	29	58	0.9
8-057-5T	5.0	120	22	22	41	77	63	157	33	64	1.3
8-057-8T	8.0	121	26	26	54	69	73	169	34	61	2.6
8-057-10T	10.0	146	20	30	54	88	73	191	41	75	3.1

* Design factor 5:1

Item No.	Working Load Limit	Dimensions (inch)									N.W.
		lbs	A	B	D	F	H	K	L	N	
8-057-1T	2200	3.27	0.55	0.55	1.06	2.24	1.57	4.29	0.94	1.97	1.1
8-057-3T	6600	3.86	0.67	0.67	1.22	2.09	1.89	4.49	1.14	2.28	2.0
8-057-5T	11000	4.72	0.87	0.87	1.61	3.03	2.48	6.18	1.30	2.52	2.9
8-057-8T	17600	4.76	1.02	1.02	2.13	2.72	2.87	6.65	1.34	2.40	5.7
8-057-10T	22000	5.75	0.79	0.79	2.13	3.46	2.87	7.52	1.61	2.95	6.2

* Design factor 5:1

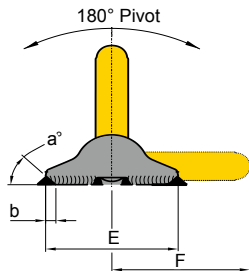
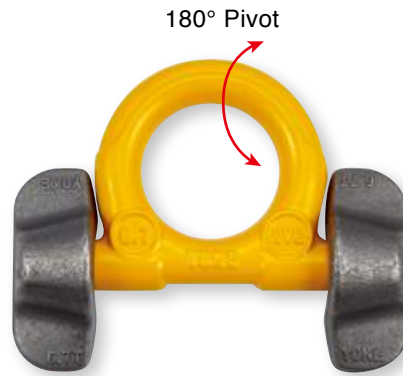
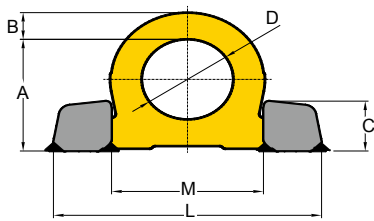

- Pivots 180°, design minimizes head room.
- Manufactured from forged alloy steel, quenched and tempered.
- Manufactured and tested in accordance with EN1677-1.
- Load rated parts are 100% magnaflux crack detected.
- The two points of attachment facilitate an even and optimal force distribution into the work piece and thus, usage of thinner base plates is possible.
- The welding block is forged out of material with excellent welding properties.
- Low profile design with high strength.
- The ring is stowable thus avoiding the hazards of tripping and snagging.



Weld-on Ring

Metric Thread (8-282)

Item No.	Working Load Limit tonnes	Dimensions (mm)										N.W. kg	
		A	B	C	D	E	F	L	M	a°	b		g
8-082-04	4	66	14	30	48	65	70	135	76	45	0.2	5	0.6
8-082-06	6.7	85	20	39	60	89	91	171	98	45	0.2	5	1.5
8-082-10	10	95	21	46	65	100	100	196	106	45	0.28	7	2.4
8-082-16	16	127	30	57	90	130	136	263	149	45	0.31	8	5.5
8-082-30	31.5	178	42	78	130	160	195	375	213	45	0.59	15	15.8

* Design factor 4:1

Weld-on Ring

UNC Thread (8-282)

Item No.	Working Load Limit lbs	Dimensions (inch)										N.W. lbs	
		A	B	C	D	E	F	L	M	a°	b		g
8-082-04	8,800	2.6	0.55	1.18	1.89	2.56	2.76	5.31	2.99	45	l	0.1	0.6
8-082-06	14,740	3.35	0.79	1.54	2.36	3.5	3.58	6.73	3.86	45	0.2	0.1	1.5
8-082-10	22,000	3.74	0.83	1.81	2.56	3.94	3.94	7.72	4.17	45	0.28	0.2	2.4
8-082-16	35,200	5	1.18	2.24	3.54	5.12	5.35	10.35	5.87	45	0.31	0.2	5.5
8-082-30	69,300	7.01	1.65	3.07	5.12	6.3	7.68	14.76	8.39	45	0.59	0.2	15.8

* Design factor 4:1

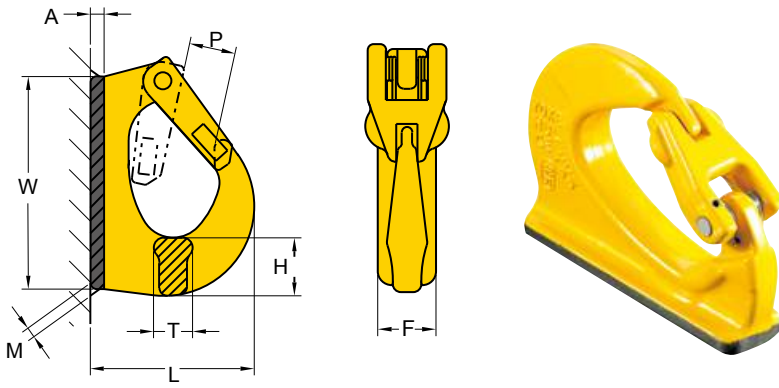

- Manufactured from forged alloy steel, quenched and tempered.
- Manufactured and tested in accordance with EN1677-1.
- Load rated parts are 100% magnaflux crack detected.
- Individual forged parts are traceable to Test Certification.
- Proof tested to 2.5 times the WLL.
- Fatigue rated to 1.5 times the WLL.
- All YOKE Lifting points meet or exceed all the requirements of ASME B30.26.
- WLL forged onto each product for quick and easy identification.
- Lugs designed to assist the welding process.
- A protected spring keeps the load ring in a required position. The parts are connected in such a way that they remain captive. The spring also reduces noise caused by vibrations.



Weld-on Hook

Metric Thread (8-081)

Item No.	Working Load Limit	Dimensions (mm)								N.W.
	tonnes	A	F	H	L	M	P	T	W	kg
8-081-01	1.0	7	25	27	70	4	18	18	95	0.6
8-081-02	2.0	8	30	30	85	5	25	20	115	1.0
8-081-03	3.0	9	35	30	107	6	28	23	133	1.4
8-081-04	4.0	10	42	38	114	7	28	30	142	2.2
8-081-05	5.0	12	44	47	135	7	30	31	167	3.0
8-081-08	8.0	12	50	52	137	8	32	39	176	3.7
8-081-10	10.0	13	56	56	170	8	44	42	222	6.2
8-081-15	15.0	14	61	67	184	10	54	45	242	7.9

* Design factor 5:1

YOKE recommends that the working load limit should be reduced to meet any appropriate legislative requirements, if welding on to an excavator. Please contact your YOKE distributors for further information.

Weld-on Hook

UNC Thread (8-081)

Item No.	Working Load Limit	Dimensions (inch)								N.W.
	lbs	A	F	H	L	M	P	T	W	lbs
8-081-01	2,200	0.28	0.98	1.06	2.83	0.24	0.71	0.67	3.74	1.3
8-081-02	4,400	0.31	1.18	1.22	3.46	0.31	0.98	0.79	4.53	2.2
8-081-03	6,600	0.35	1.38	1.18	4.21	0.39	1.1	0.91	5.24	3.1
8-081-04	8,800	0.39	1.65	1.5	4.41	0.43	1.1	1.18	5.55	4.4
8-081-05	11,000	0.47	1.73	1.81	5.24	0.51	1.18	1.22	6.57	6.6
8-081-08	17,600	0.47	1.97	2.13	5.39	0.55	1.26	1.54	6.89	8.4
8-081-10	22,000	0.51	2.2	2.2	6.61	0.63	1.73	1.65	8.74	13.9
8-081-15	33,000	0.55	2.4	2.64	7.24	0.67	2.13	1.77	9.49	17.4

* Design factor 5:1

YOKE recommends that the working load limit should be reduced to meet any appropriate legislative requirements, if welding on to an excavator. Please contact your YOKE distributors for further information.

YOKE®

EXTREME-100



EX TREME-100









DANGER: Overhead lifting presents a very real danger of severe injury or loss of life if lifting equipment is not used properly. Please read and understand all of these instructions prior to using any lifting sling or sling assembly. Sling should only be used by qualified persons who are responsible for the sling selection, inspection and use.

Grade 100 Chain Sling Components

WORKING LOAD LIMITS IN LBS acc. to PAS 1061

Load Factor		1.0	1.4	1.0	2.1	1.5	1.6
Chain Size		-	0 β 45	45 β 60	0 β 45	45 β 60	
mm	inch	Working Load Limit (lbs)					
6	7/32	3,200	4,500	3,200	6,800	4,800	5,100
7	1/4 (9/32)	4,300	6,100	4,300	9,100	6,400	6,900
8	5/16	5,700	8,100	5,700	12,100	8,500	9,100
10	3/8	8,800	12,400	8,800	18,700	13,200	14,100
13	1/2	15,000	21,200	15,000	31,800	22,500	24,000
16	5/8	22,600	32,000	22,600	47,900	33,900	36,200
20	3/4	35,300	49,900	35,300	74,900	52,950	56,500
22	7/8	42,700	60,400	42,700	90,600	64,000	68,300
26	1	59,700	84,400	59,700	12,600	89,550	95,500
32	1 1/4	90,400	127,800	90,400	191,700	135,600	144,600

** Safety factor 4:1 Above limits are valid for standard use and equally loaded slings. Properly used and maintained your YOKE chain slings will give long life and will enable you to carry out your lifting operations efficiently and safety.

Warning: Never exceed a Vertical sling angle of 60°

SAFE USE

- Never load in excess of the rated capacity for the application.
- Keep a record of all slings in use.
- User should remove all twists from a chain leg before lifting and, should never knot a chain.
- Always use YOKE shortening hook or clutch when chain slings should be shortened.
- Always inspect to insure that chain is free from damage or wear before use.
- Always inspect all sling components prior to each use.
- Ensure that chain is protected from any sharp corners on the load.
- Ensure that the master link articulates freely on the hook of the crane or other lifting appliance.
- Never tip load hooks. The load should always be supported correctly in the bowl of the hook.
- Always use the correct size sling for the load, allowing for the included angle and the possibility of unequal loading.
- Personnel must keep all body parts from between the sling and the load, and from between the sling and the crane/hoist hook. Persons shall never ride the chain sling/rope sling or web sling or the load during lifting or while suspended. Persons must stand clear of all loads while lifting or while suspended. During lifting, with or without the load, personnel must be alert for possible snagging of the load or the chain sling.

MAINTENANCE

- A thorough examination should be carried out by a competent person at intervals at least every year or more frequently according to statutory regulations, type of use and past records.
- Chains with bent links or with cracks or gouges in the link should be replaced , as should deformed components such as bent master links , deformed hooks and any fittings showing signs of damage.
- Chain and components wear should never exceed 10%of the original dimensions.
- Once a chain sling has been overloaded it must be taken out of service.
- Store chain slings on a properly designed rack. They should not be left lying on the floor where they may suffer mechanical or corrosion damage or may be lost.

LIMITATION ON USE

- YOKE alloy chain or chain slings should not be used in acid or caustic solutions nor in heavily acidic or caustic laden atmospheres. The high tensile strength of the heat treated alloy material in alloy steel chains and components is susceptible to hydrogen embrittlement when exposed to acids.
- YOKE slings must not be heat-treated, galvanized, plated, coated or subject to any process involving heating or pickling. Each of these processes can have dangerous effects and will invalidate the manufacturer certificate.
- YOKE slings may be used at temperatures between -40°C to 200°C with no reduction in the working load limit . The use of YOKE chain slings within the permissible temperature range in the table below does not require any permanent reduction in working load limit when the chain sling is returned to normal temperatures. A sling accidentally exposed to temperatures in excess of the maximum permissible should be withdrawn form service immediately and returned to the distributor for thorough examination.

- When using YOKE slings in exceptionally ha
competent person and the Working Load Limit adjusted accordingly. Examples are lifting of potentially dangerous loads such as molten metals, corrosive materials or fissile material and including certain offshore activities.

Sling temperature (F)	Sling temperature (C)	Reduction in Working Load Limit
-40°F to 400°F	-40°C to 200°C	None
400°F to 550°F	200°C to 300°C	10%
550°F to 750°F	300°C to 400°C	25%
Above 750°F	Above 400°C	Do not use.

Examples Of Chain Slings

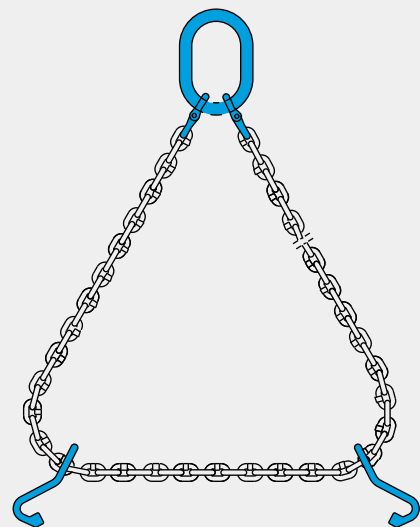
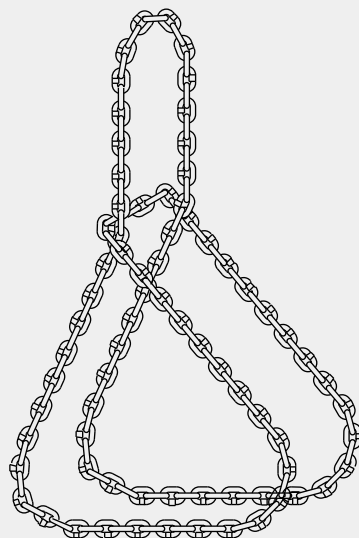
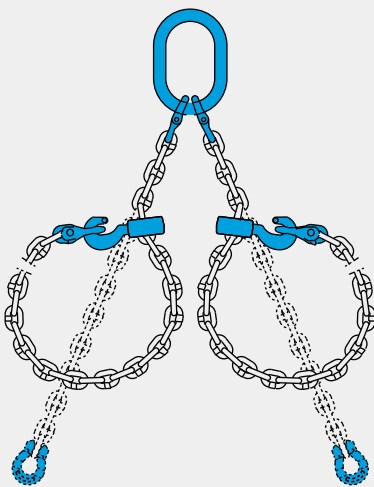
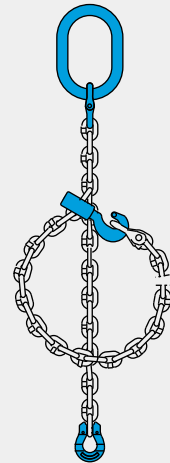
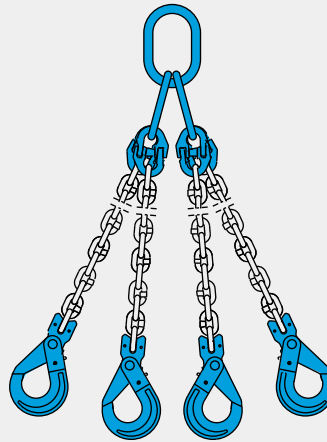
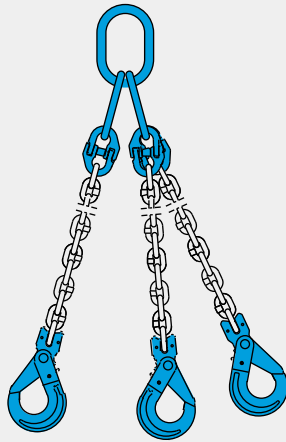
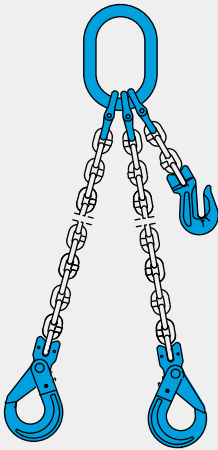
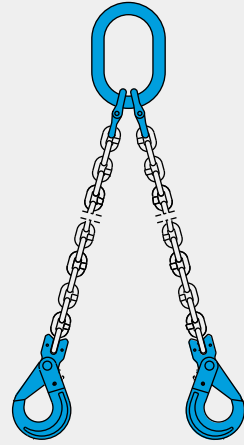
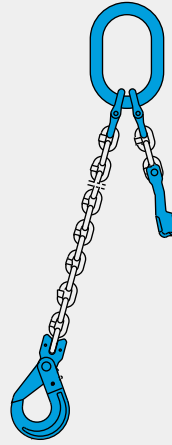

Examples Of Wire Rope Sling & Web Sling

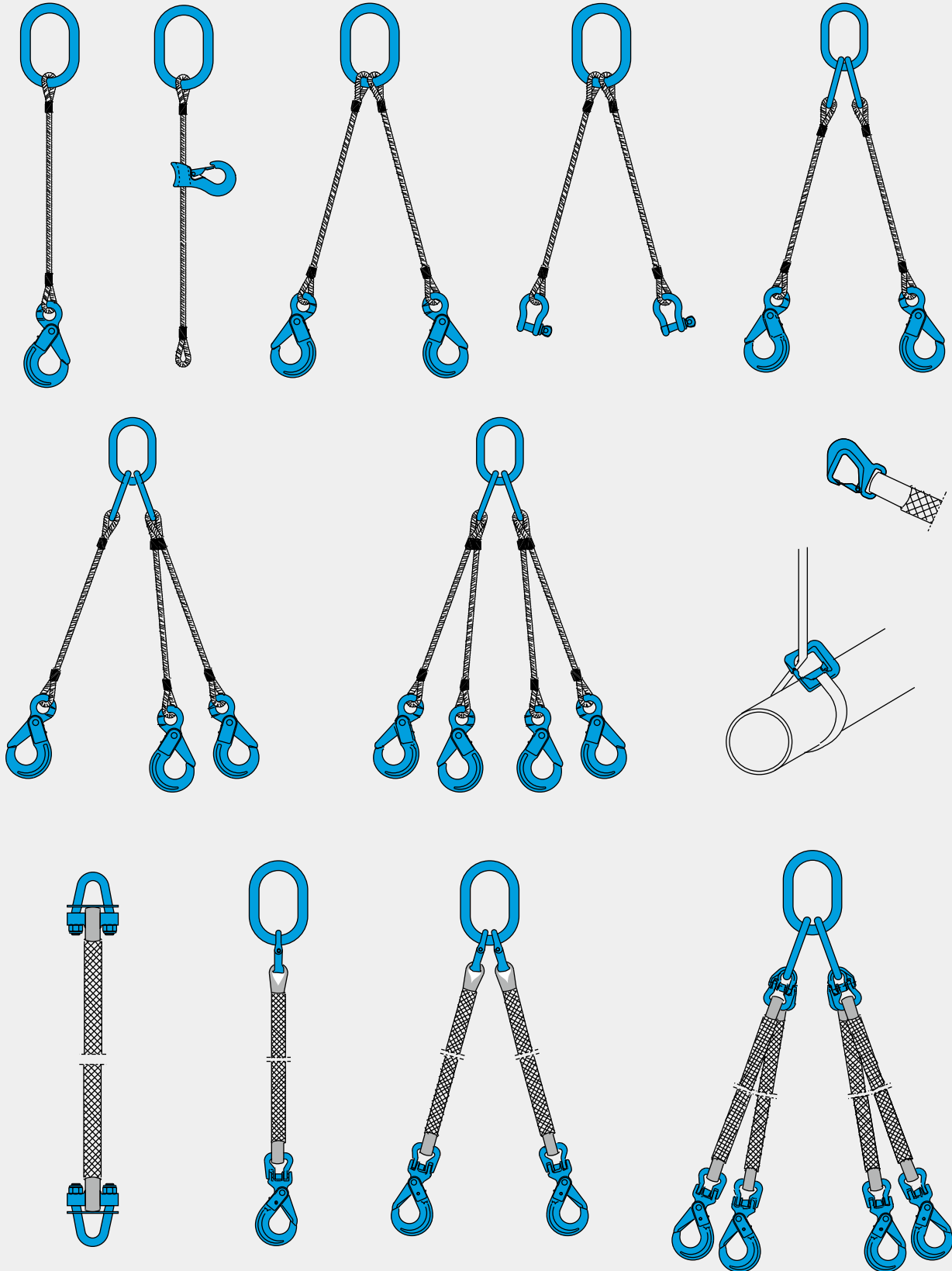

Incorrect Use

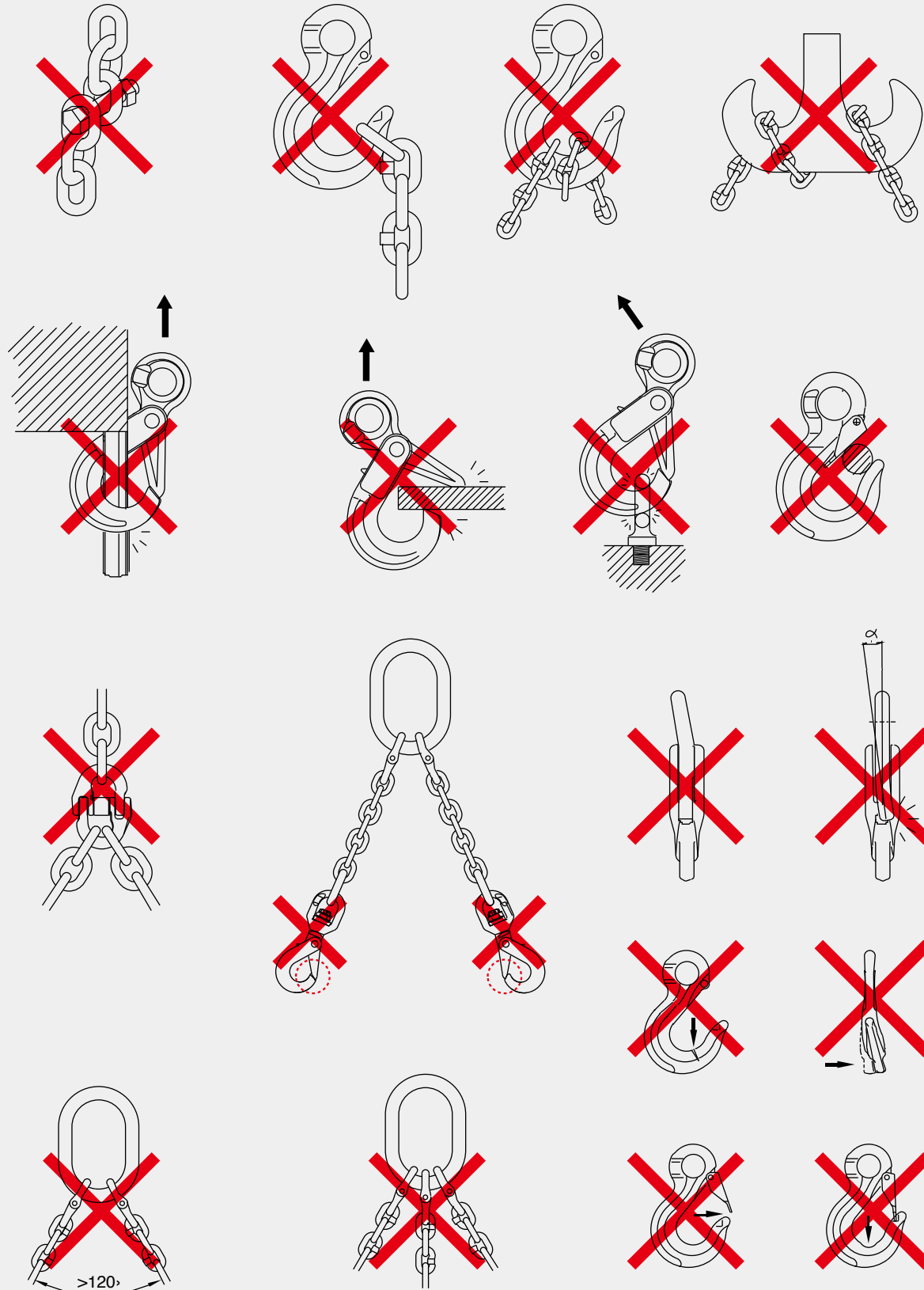





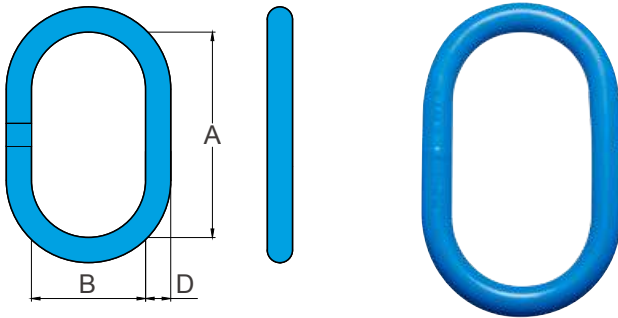

- Quenched and Tempered Alloy Steel.
- At least 25% greater WLL than traditional G80 products.
- Manufactured in accordance with ASTM A906/A906M, ASTM A952/A952M, ASME B30.9, ASME B30.10, ASME B30.26 and OSHA 1910.184, EN-1677-4.
- Proof Load tested at 2.5 times the WLL with certification for each batch manufactured.
- Design Factor 5:1.
- Fatigue rated to 20,000 cycles at 1.5 times the WLL.
- Tempering temperature at a minimum of 400°C.
- Welded Master Link designed for 1-2 legs Wire Rope and Chain Slings.
- Each link is marked with batch number that links to the test certificate with full traceability to raw materials.

G-100 Enlarged Welded Master Link

Item No.	For Chain		WLL β 0-45° tonnes	Proof Load kN	Dimensions (inch)			N.W. lbs
	single-leg	double-leg			D	A	B	
X-001-13	7/32 - 5/16	7/32	2.8	69	0.51	4.72	2.36	0.7
X-001-1601	3/8	1/4 - 5/16	4	98	0.63	5.51	2.76	1.5
X-001-16	3/8	1/4 - 5/16	4	98	0.63	6.30	3.54	1.8
X-001-19	1/2	3/8	6.7	164	0.75	6.30	3.54	2.4
X-001-22	1/2	3/8	8.5	208	0.87	7.09	3.94	3.5
X-001-25	5/8	1/2	11.5	282	0.98	8.27	4.53	5.3
X-001-2501	5/8	1/2	11.5	282	0.98	10.83	5.71	6.8
X-001-2801	5/8	1/2	13	319	1.10	7.48	3.94	6.2
X-001-28	5/8	1/2	13	319	1.10	10.83	5.71	8.6
X-001-32	3/4	5/8	17	417	1.26	10.83	5.71	11.4
X-001-3601	7/8	3/4	24	588	1.42	10.83	5.71	14.5
X-001-36	7/8	3/4	24	588	1.42	11.22	6.10	15.2
X-001-4001	1	7/8	28.1	689	1.57	10.24	5.12	17.2
X-001-40	1	7/8	28.1	689	1.57	11.81	6.30	19.8
X-001-45	1	1	38.3	939	1.77	13.39	7.09	28.2
X-001-50	1-1/4	1	45	1103	1.97	13.78	7.68	36.5
X-001-6001	-	-	65	1593	2.36	16.14	8.66	61.4
**X-001-60	-	-	65	1593	2.36	16.93	9.06	64.2
**X-001-7001	-	-	85	2083	2.76	15.75	7.87	82.9
**X-001-70	-	-	85	2083	2.76	18.90	10.24	97.5
**X-001-90	-	-	150	3675	3.54	19.69	11.81	189.2

★ Design factor 5:1 proof tested and certified.

★★ Available from February, 2018

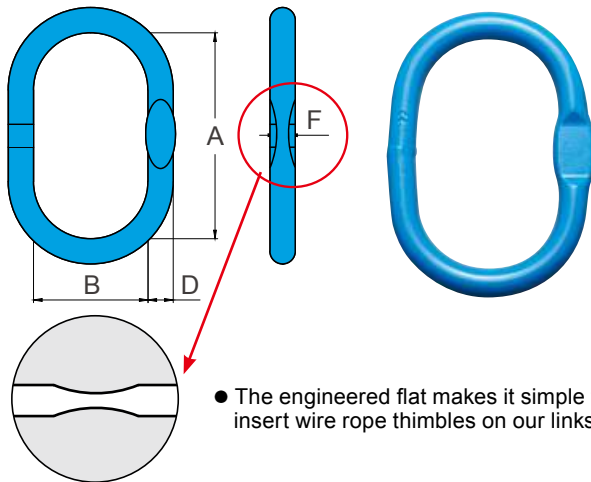

● The engineered flat makes it simple to insert wire rope thimbles on our links.

- Quenched and Tempered Alloy Steel.
- At least 25% greater WLL than traditional G80 products.
- Manufactured in accordance with ASTM A906/A906M, ASTM A952/A952M, ASME B30.9, ASME B30.10, ASME B30.26 and OSHA 1910.184, EN-1677-4.
- Proof Load tested at 2.5 times the WLL with certification for each batch manufactured.
- Design Factor 5:1.
- Fatigue rated to 20,000 cycles at 1.5 times the WLL.
- Tempering temperature at a minimum of 400°C.
- Welded Master Link designed for 1-2 legs Wire Rope and Chain Slings.
- Each link is marked with batch number that links to the test certificate with full traceability to raw materials.

G-100 Enlarged Welded Master Link with engineered flat

Item No.	For Chain		WLL b 0-45° tonnes	Proof Load kN	Dimensions (inch)			N.W. lbs
	Single Leg	Double Leg			D	A	B	
X-001F-13	7/32 - 5/16	7/32	2.8	69	0.51	4.72	2.36	0.7
X-001F-1601	3/8	1/4 - 5/16	4	98	0.63	5.51	2.76	1.5
X-001F-16	3/8	1/4 - 5/16	4	98	0.63	6.30	3.54	1.8
X-001F-19	1/2	3/8	6.7	164	0.75	6.30	3.54	2.4
X-001F-22	1/2	3/8	8.5	208	0.87	7.09	3.94	3.5
X-001F-25	5/8	1/2	11.5	282	0.98	8.27	4.53	5.3
X-001F-2501	5/8	1/2	11.5	282	0.98	10.83	5.71	6.8
X-001F-2801	5/8	1/2	13	319	1.10	7.48	3.94	6.2
X-001F-28	5/8	1/2	13	319	1.10	10.83	5.71	8.6
X-001F-32	3/4	5/8	17	417	1.26	10.83	5.71	11.4
X-001F-3601	7/8	3/4	24	588	1.42	10.83	5.71	14.5
X-001F-36	7/8	3/4	24	588	1.42	11.22	6.10	15.2
X-001F-4001	1	7/8	28.1	689	1.57	10.24	5.12	17.2
X-001F-40	1	7/8	28.1	689	1.57	11.81	6.30	19.8
X-001F-45	1	1	38.3	939	1.77	13.39	7.09	28.2
X-001F-50	1-1/4	1	45	1103	1.97	13.78	7.68	36.5
X-001F-6001	-	-	65	1593	2.36	16.14	8.66	61.4
**X-001F-60	-	-	65	1593	2.36	16.93	9.06	64.2
**X-001F-7001	-	-	85	2083	2.76	15.75	7.87	82.9
**X-001F-70	-	-	85	2083	2.76	18.90	10.24	97.5
**X-001F-90	-	-	150	3675	3.54	19.69	11.81	189.2

★ Design factor 5:1 proof tested and certified.

★★ Available from February, 2018



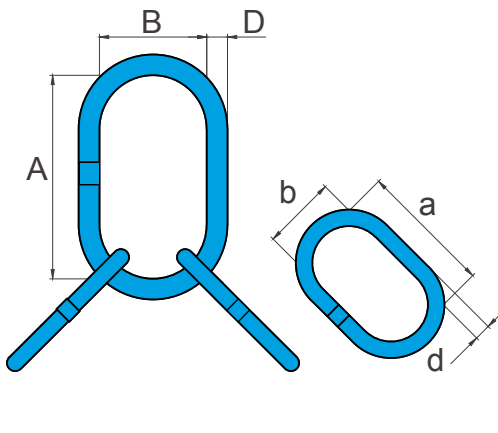

- Quenched and Tempered Alloy Steel.
- At least 25% greater WLL than traditional G80 products.
- Manufactured in accordance with ASTM A906/A906M, ASTM A952/A952M, ASME B30.9, ASME B30.10, ASME B30.26 and OSHA 1910.184, EN-1677-4.
- Proof Load tested at 2.5 times the WLL with certification for each batch manufactured.
- Design Factor 5:1.
- Fatigue rated to 20,000 cycles at 1.5 times the WLL.
- Tempering temperature at a minimum of 400°C.
- Welded Master Link designed for 3-4 legs Wire Rope and Chain Slings.
- Each link is marked with batch number that links to the test certificate with full traceability to raw materials.

G-100 Enlarged Welded Master Link Assembly

Item No.	For Chain	WLL β 0-45° tonnes	Proof Load kN	Dimensions (inch)						N.W. lbs
				D	A	B	d	a	b	
X-007-20	3 and 4-leg 1/4 - 5/16	5.3	130	0.75	6.30	3.54	0.63	5.51	2.76	5.50
X-007-25	3/8	8.9	218	0.98	10.83	5.71	0.75	6.30	3.54	9.90
X-007-28	3/8	12.9	316	1.10	10.83	5.71	0.87	7.09	3.94	15.62
X-007-32	1/2	17.0	417	1.26	10.83	5.71	0.98	8.27	4.53	22.00
X-007-36	5/8	23.6	579	1.42	10.83	5.71	1.10	7.48	3.94	26.84
X-007-40	5/8	28.1	689	1.57	11.81	6.30	1.26	10.83	5.71	42.46
X-007-45	3/4	38.3	939	1.77	13.39	7.09	1.42	11.22	6.10	58.52
X-007-50	7/8	45	1103	1.97	13.78	7.68	1.57	10.24	5.12	71.06
X-007-60	1	65	1593	2.36	16.93	9.06	1.97	13.78	7.68	140.58
X-007-70	1-1/4	85	2083	2.76	18.90	10.24	2.36	16.14	8.66	225.72
X-007-90	-	150	3675	3.54	19.69	11.81	2.76	15.75	7.87	360.80

★ Design factor 5:1 proof tested and certified.

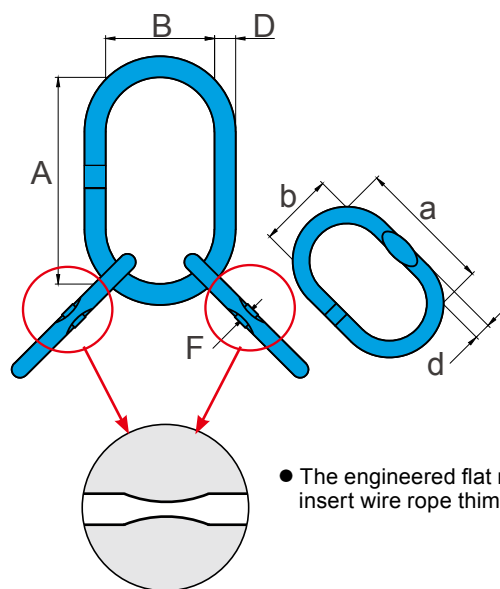

● The engineered flat makes it simple to insert wire rope thimbles on our links.



- Quenched and Tempered Alloy Steel.
- At least 25% greater WLL than traditional G80 products.
- Manufactured in accordance with ASTM A906/A906M, ASTM A952/A952M, ASME B30.9, ASME B30.10, ASME B30.26 and OSHA 1910.184, EN-1677-4.
- Proof Load tested at 2.5 times the WLL with certification for each batch manufactured.
- Design Factor 5:1.
- Fatigue rated to 20,000 cycles at 1.5 times the WLL.
- Tempering temperature at a minimum of 400°C.
- Welded Master Link designed for 3-4 legs Wire Rope and Chain Slings.
- Each link is marked with batch number that links to the test certificate with full traceability to raw materials.

G-100 Enlarged Welded Master Link Assembly

with engineered flat

Item No.	For Chain 3 and 4-leg	WLL β 0-45° tonnes	Proof Load kN	Dimensions (inch)						N.W. lbs
				D	A	B	d	a	b	
X-007F-20	1/4 - 5/16	5.3	130	0.75	6.30	3.54	0.63	5.51	2.76	5.50
X-007F-25	3/8	8.9	218	0.98	10.83	5.71	0.75	6.30	3.54	9.90
X-007F-28	3/8	12.9	316	1.10	10.83	5.71	0.87	7.09	3.94	15.62
X-007F-32	1/2	17.0	417	1.26	10.83	5.71	0.98	8.27	4.53	22.00
X-007F-36	5/8	23.6	579	1.42	10.83	5.71	1.10	7.48	3.94	26.84
X-007F-40	5/8	28.1	689	1.57	11.81	6.30	1.26	10.83	5.71	42.46
X-007F-45	3/4	38.3	939	1.77	13.39	7.09	1.42	11.22	6.10	58.52
X-007F-50	7/8	45	1103	1.97	13.78	7.68	1.57	10.24	5.12	71.06
X-007F-60	1	65	1593	2.36	16.93	9.06	1.97	13.78	7.68	140.58
X-007F-70	1-1/4	85	2083	2.76	18.90	10.24	2.36	16.14	8.66	225.72
X-007F-90	-	150	3675	3.54	19.69	11.81	2.76	15.75	7.87	360.80

★ Design factor 5:1 proof tested and certified.



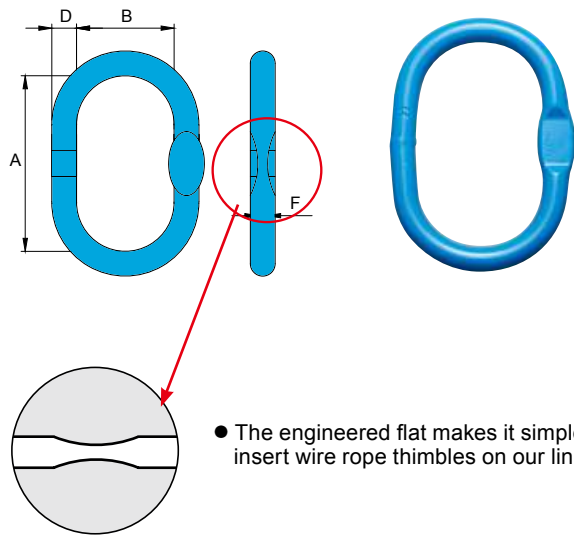

● The engineered flat makes it simple to insert wire rope thimbles on our links

- Quenched and Tempered Alloy Steel.
- At least 25% greater WLL than traditional G80 products.
- Manufactured in accordance with ASTM A906/A906M, ASTM A952/A952M, ASME B30.9, ASME B30.10, ASME B30.26 and OSHA 1910.184, EN-1677-4.
- Proof Load tested at 2.5 times the WLL with certification for each batch manufactured.
- Design Factor 4:1.
- Fatigue rated to 20,000 cycles at 1.5 times the WLL.
- Tempering temperature at a minimum of 400°C.
- Welded Master Link designed for 1-2 legs Wire Rope and Chain Slings.
- Each link is marked with batch number that links to the test certificate with full traceability to raw materials.

G-100 Welded EN Master Link

with engineered flat

Item No.	For Chain		WLL β 0-45° tonnes	Proof Load kN	Dimensions (inch)				N.W. lbs
	Single Leg	Duble Leg			D	A	B	F	
X-002F-06	1/4-5/16	7/32	2.8	67	0.51	4.33	2.36	0.24	0.7
X-002F-07	3/8	1/4-5/16	4	86	0.63	4.33	2.36	0.30	1.2
X-002F-10	1/2	3/8	6.7	123	0.75	5.31	2.95	0.30	2.0
X-002F-13	1/2	3/8	8.5	201	0.87	6.30	3.54	0.41	3.3
X-002F-16	5/8	1/2	11.5	263	1.10	7.09	3.94	0.53	4.8
X-002F-20	3/4	5/8	17	392	1.26	7.87	4.33	0.61	8.8
X-002F-22	7/8	3/4	25.1	615	1.42	10.24	5.51	0.73	13.9
X-002F-26	1	7/8	38.3	939	1.77	11.81	7.09	0.91	26.0
X-002F-32	1 1/4	1 1/8	45	1054	1.97	11.81	7.87	0.98	33.4
X-002F-40	1 5/8	1 1/4	64	1568	2.36	15.75	7.87	1.18	59.4
X-002F-45	1 3/4	1 3/8	85	2083	2.76	18.11	9.84	1.38	99.0

★ Design factor 4:1 proof tested and certified.

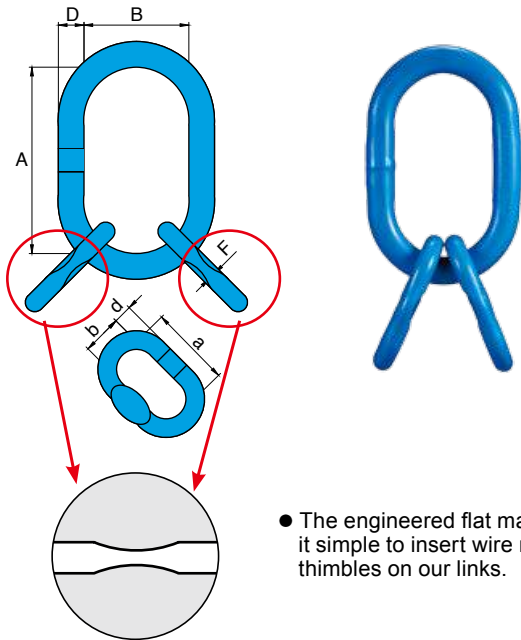

● The engineered flat makes it simple to insert wire rope thimbles on our links.

- Quenched and Tempered Alloy Steel.
- At least 25% greater WLL than traditional G80 products.
- Manufactured in accordance with ASTM A906/A906M, ASTM A952/A952M, ASME B30.9, ASME B30.10, ASME B30.26 and OSHA 1910.184, EN-1677-4.
- Proof Load tested at 2.5 times the WLL with certification for each batch manufactured.
- Design Factor 4:1.
- Fatigue rated to 20,000 cycles at 1.5 times the WLL.
- Tempering temperature at a minimum of 400°C.
- Welded Master Link designed for 3-4 legs Wire Rope and Chain Slings.
- Each link is marked with batch number that links to the test certificate with full traceability to raw materials.

G-100 Welded EN Master Link Assembly

with engineered flat

Item No.	For Chain	WLL β 0-45° tonnes*	Proof Load kN	Dimensions (inch)							N.W. lbs
				D	A	B	d	a	b	F	
X-006F-06	3 and 4-leg 7/32	4.2	103	0.75	5.31	2.95	0.51	2.13	0.98	0.24	2.9
X-006F-07	1/4-5/16	8.2	201	0.87	6.30	3.54	0.63	2.76	1.34	0.30	4.8
X-006F-10	3/8	10.7	263	0.98	7.09	3.94	0.75	3.35	1.57	0.41	7.5
X-006F-13	1/2	14.1	353	1.26	7.87	4.33	0.87	4.53	1.97	0.53	13.4
X-006F-16	5/8	21.2	520	1.42	10.24	5.51	0.98	5.51	2.56	0.61	21.3
X-006F-20	3/4	34.1	836	1.97	11.81	7.87	1.26	5.91	2.76	0.73	46.9
X-006F-22	7/8	40	980	1.97	11.81	7.87	1.42	6.69	2.95	0.73	52.4
X-006F-26	1	56	1373	2.36	15.75	7.87	1.77	6.69	3.15	0.91	90.9
X-006F-32	1-1/4	85	2085	2.76	18.11	9.84	1.97	7.87	3.94	0.98	146.5

★ Design factor 4:1 proof tested and certified.

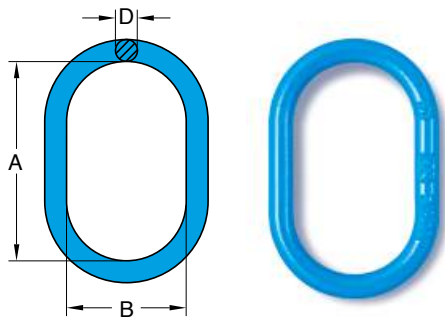

- Quenched and Tempered Alloy Steel.
- At least 25% greater WLL than traditional G80 products.
- Manufactured in accordance with ASTM A906/A906M, ASTMA952/A952M, ASME B30.9, ASME B30.10, ASME B30.26 and OSHA 1910.184, EN-1677-4.
- Proof Load tested at 2.5 times the WLL with certification for each batch manufactured.
- Design Factor 4:1.
- Fatigue rated to 20,000 cycles at 1.5 times the WLL.
- Tempering temperature at a minimum of 400°C.
- Designed for Wire Rope and Chain.
- Each link is marked with batch number that links to the test certificate with full traceability to raw materials.

Forged

G-100 Forged Oblong Master Link

Item No.	For Chain		WLL β 0-45° tonnes	Proof Load kN	Dimensions (inch)			N.W. lbs
	Single Leg	Double Leg			D	A	B	
X-003-06	7/32		1.4	34	0.43	3.94	2.36	0.4
X-003-0806	1/4-5/16	7/32	2.9	71	0.55	4.72	2.76	1.1
X-003-1008	3/8	1/4-5/16	5.3	130	0.67	5.51	3.15	1.5
X-003-13	1/2		6.7	164	0.75	5.91	3.54	2.4
X-003-1310	1/2	3/8	8.4	206	0.87	6.30	3.74	3.3
X-003-16	5/8		10.0	245	0.98	7.48	4.33	5.1
X-003-1613	5/8	1/2	14.1	345	1.10	7.09	4.13	5.9
X-003-19	3/4		16.0	392	1.18	7.87	4.72	7.7
X-003-2216	7/8	5/8	21.0	515	1.34	9.45	5.51	11.7
X-003-26	1		26.5	649	1.50	9.84	5.91	16.3
X-003-2619	1	3/4	33.6	823	1.57	9.84	5.91	18.3
X-003-3222	1-1/4	7/8	39.9	978	1.77	11.81	7.09	27.1

★ Design factor 4:1 proof tested and certified.

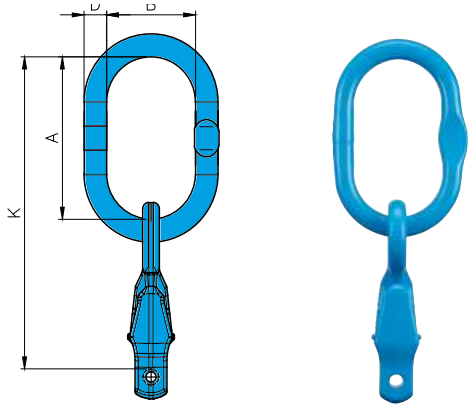

- Quenched and Tempered Alloy Steel.
- At least 25% greater WLL than traditional G80 products.
- Manufactured in accordance with ASTM A906/ A906M, ASTM A952/A952M, ASME B30.9, ASME B30.10, ASME B30.26 and OSHA 1910.184, EN-1677-4.
- Proof Load tested at 2.5 times the WLL with certification for each batch manufactured.
- Design Factor 4:1.
- Fatigue rated to 20,000 cycles at 1.5 times the WLL.
- Tempering temperature at a minimum of 400°C.
- Each link is marked with batch number that links to the test certificate with full traceability to raw materials.
- Fully integrated shortening clutch and master link.
- No reduction in WLL when shortening chain.
- Speedy assembly.
- Light weight system.
- Cost effective compared to slings which use multiple components.

G100 GrabEX Single Leg Assembly

Item No.	Code	WLL tonnes	For Grade 100 Chain mm	Can be used on single hook acc. To DIN15401 no.	Dimensions (inch)				N.W. lbs
					D	A	B	K	
X-A04-06	XAF-06	1.4	6	4	0.51	4.72	2.76	7.7	1.5
X-A04-07	XAF-07	1.9	7	4	0.51	4.72	2.76	8.73	2.1
X-A04-08	XAF-08	2.5	8	5	0.63	5.51	3.15	9.53	2.7
X-A04-10	XAF-10	4	10	6	0.75	6.3	3.74	11.22	4.7
X-A04-13	XAF-13	6.7	13	10	0.87	6.69	4.13	12.92	8.5
X-A04-16	XAF-16	10	16	10	1.1	7.48	4.33	15.41	15.5

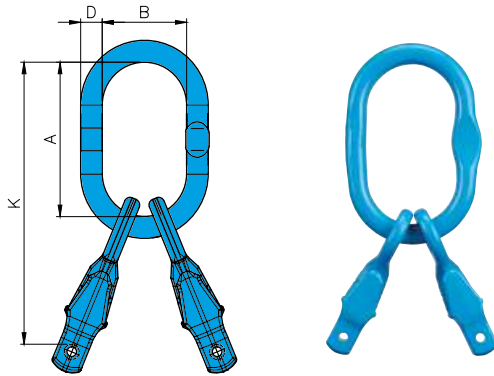

- Quenched and Tempered Alloy Steel.
- At least 25% greater WLL than traditional G80 products.
- Manufactured in accordance with ASTM A906/ A906M, ASTM A952/A952M, ASME B30.9, ASME B30.10, ASME B30.26 and OSHA 1910.184, EN-1677-4.
- Proof Load tested at 2.5 times the WLL with certification for each batch manufactured.
- Design Factor 4:1.
- Fatigue rated to 20,000 cycles at 1.5 times the WLL.
- Tempering temperature at a minimum of 400°C.
- Each link is marked with batch number that links to the test certificate with full traceability to raw materials.
- Fully integrated shortening clutch and master link.
- No reduction in WLL when shortening chain.
- Speedy assembly.
- Light weight system.
- Cost effective compared to slings which use multiple components.

G100 GrabEX 2-Leg Assembly

Item No.	Code	WLL tonnes	For Grade 100 Chain inch	Can be used on single hook acc. To DIN15401 no.	Dimensions (inch)				N.W. lbs
					D	A	B	K	
X-A05-06	XAG-06	2	1/4	4	0.51	4.72	2.76	7.7	2.0
X-A05-07	XAG-07	2.65	9/32	5	0.63	5.51	3.15	9.52	3.8
X-A05-08	XAG-08	3.55	5/16	6	0.75	6.3	3.74	10.31	4.8
X-A05-10	XAG-10	5.6	3/8	10	0.87	6.69	4.13	11.61	8.3
X-A05-13	XAG-13	9.5	1/2	10	1.1	7.48	4.33	13.7	15.4
X-A05-16	XAG-16	14	5/8	12	1.26	9.06	5.12	16.99	29.8

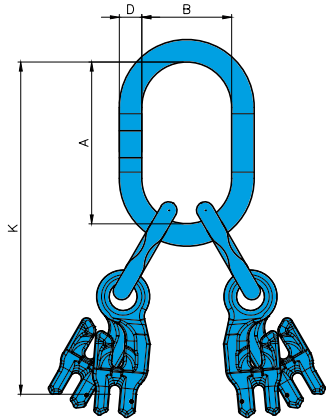

- Quenched and Tempered Alloy Steel.
- At least 25% greater WLL than traditional G80 products.
- Manufactured in accordance with ASTM A906/A906M, ASTM A952/A952M, ASME B30.9, ASME B30.10, ASME B30.26 and OSHA 1910.184, EN-1677-4.
- Proof Load tested at 2.5 times the WLL with certification for each batch manufactured.
- Design Factor 4:1.
- Fatigue rated to 20,000 cycles at 1.5 times the WLL.
- Tempering temperature at a minimum of 400°C.
- Each link is marked with batch number that links to the test certificate with full traceability to raw materials.
- Fully integrated shortening clutch and master link.
- No reduction in WLL when shortening chain.
- Speedy assembly.
- Light weight system.
- Cost effective compared to slings which use multiple components.

G100 GrabEX 4-Leg Assembly

Item No.	Code	WLL tonnes	For Grade 100 Chain inch	Can be used on single hook acc. To DIN15401 no.	Dimensions (inch)				N.W. lbs
					D	A	B	K	
X-A06-06	XAH-06	3	1/4	6	0.75	6.3	3.74	10.28	5.3
X-A06-07	XAH-07	4	9/32	10	0.87	6.3	4.33	11.65	9.9
X-A06-08	XAH-08	5.3	5/16	10	0.87	6.69	4.13	12.05	10.1
X-A06-10	XAH-10	8	3/8	10	1.1	7.48	4.33	13.98	17.8
X-A06-13	XAH-13	14	1/2	12	1.26	9.06	5.12	17.24	34.8
X-A06-16	XAH-16	21.2	5/8	20	1.5	10.83	5.91	21.34	63.6

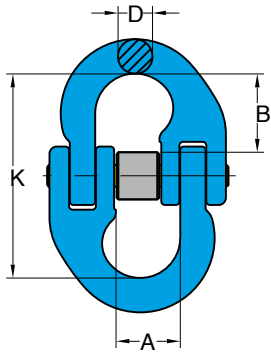

- Quenched and Tempered Alloy Steel.
- At least 25% greater WLL than traditional G80 products.
- Manufactured in accordance with EN 1677- 1 and ASTM A952/ A952M, DIN PAS 1061.
- Proof Load tested at 2.5 times the WLL with certification for each batch manufactured.
- Design Factor 4:1.
- Fatigue rated to 20,000 cycles at 1.5 times the WLL.
- Suitable for use with both Grade 80 and Grade 100 chain.



Repair kit available for maintenance.

G-100 Connecting Link

Item No.	For Grade 100 Chain	WLL		Dimensions (inch)				N.W.
	inch	lbs*	tonnes*	A	B	D	K	lbs
X-015-06	7/32	3,200	1.4	0.59	0.71	0.28	1.77	0.2
X-015-07	1/4-5/16	5,700	2.5	0.71	0.98	0.35	2.32	0.4
X-015-10	3/8	8,800	4.0	0.98	1.10	0.43	2.72	0.7
X-015-13	1/2	15,000	6.7	1.18	1.50	0.63	3.62	1.5
X-015-16	5/8	22,600	10.0	1.42	1.61	0.75	3.98	2.6
X-015-20	3/4	35,300	16.0	1.65	1.97	0.91	4.80	4.6
X-015-22	7/8	42,700	19.0	1.93	2.48	0.95	5.98	7.7
X-015-26	1	59,700	26.5	2.17	2.60	1.18	6.38	10.6
X-015-32	1-1/4	90,400	40.0	2.72	3.35	1.42	7.99	19.8

★ Design factor 4:1 proof tested and certified.

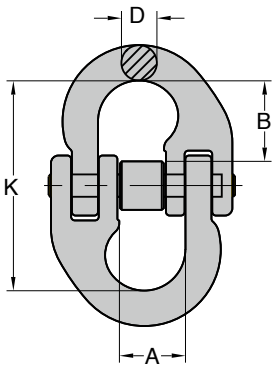

- Quenched and Tempered Alloy Steel.
- At least 25% greater WLL than traditional G80 products.
- Manufactured in accordance with EN 1677- 1 and ASTM A952/ A 952M, DIN PAS 1061.
- Proof Load tested at 2.5 times the WLL with certification for each batch manufactured.
- Design Factor 4:1.
- Fatigue rated to 20,000 cycles at 1.5 times the WLL.
- Suitable for use with both Grade 80 and Grade 100 chain.
- Dacromet surface finish for enhanced corrosion resistance.



Special pin and sleeve designed for maintenance purpose.

G-100 Connecting Link

Dacromet® surface finish**

Item No.	For Grade 100 Chain	WLL		Dimensions (inch)				N.W.
	inch	lbs*	tonnes*	A	B	D	K	lbs
X-M015-06	7/32	3,200	1.4	0.59	0.71	0.28	1.77	0.2
X-M015-07	1/4-5/16	5,700	2.5	0.71	0.98	0.35	2.32	0.4
X-M015-10	3/8	8,800	4.0	0.98	1.10	0.43	2.72	0.7
X-M015-13	1/2	15,000	6.7	1.18	1.50	0.63	3.62	1.5
X-M015-16	5/8	22,600	10.0	1.42	1.61	0.75	3.98	2.6
X-M015-20	3/4	35,300	16.0	1.65	1.97	0.91	4.80	4.6
X-M015-22	7/8	42,700	19.0	1.93	2.48	0.95	5.98	7.7
X-M015-26	1	59,700	26.5	2.17	2.60	1.18	6.38	10.6
X-M015-32	1-1/4	90,400	40.0	2.72	3.35	1.42	7.99	19.8

★ Design factor 4:1 proof tested and certified.

YOKE

YOKE[®]

Safety is our first priority[™]

New!
Safety Triggers



Quality approval by:



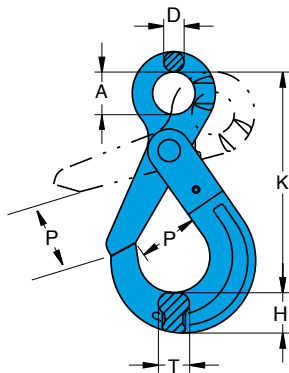

- Quenched and Tempered Alloy Steel.
- At least 25% greater WLL than traditional G80 products.
- Manufactured in accordance with EN 1677- 3 and ASME B30.26.
- Proof Load tested at 2.5 times the WLL with certification for each batch manufactured.
- Design Factor 4:1.
- Fatigue rated to 20,000 cycles at 1.5 times the WLL.
- Tempering temperature minimum 400°C
- Magnaflux crack detection is performed 100% on each batch.



8-P025
For most sizes



8-P025T
For 26mm

G-100 Eye Self Locking Hook

Item No.	For Grade 100 Chain	WLL		Dimensions (inch)						N.W.
		inch	lbs*	tonnes*	A	D	H	K	P	T
X-025-06	7/32	3,200	1.4	0.83	0.39	0.87	4.33	1.10	0.59	1.1
X-025-07	1/4-5/16	5,700	2.5	0.98	0.43	1.02	5.35	1.34	0.79	1.8
X-025-10	3/8	8,800	4.0	1.26	0.51	1.34	6.57	1.73	1.02	3.3
X-025-13	1/2	15,000	6.7	1.57	0.63	1.65	8.15	2.01	1.18	6.6
X-025-16	5/8	22,600	10.0	1.97	0.83	2.20	9.92	2.36	1.42	12.8
X-025-20	3/4	35,300	16.0	2.36	0.91	2.56	11.42	2.76	2.09	22.0
X-025-22	7/8	42,700	19.0	2.76	0.94	2.80	12.56	3.15	1.93	27.5
X-025-26	1	59,700	26.5	3.15	0.98	3.11	13.50	3.90	2.20	33.0

★ Design factor 4:1 proof tested and certified.

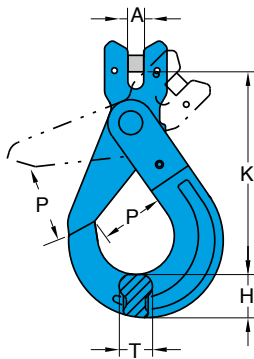

- Quenched and Tempered Alloy Steel.
- At least 25% greater WLL than traditional G80 products.
- Manufactured in accordance with EN 1677- 3 and ASME B30.26.
- Proof Load tested at 2.5 times the WLL with certification for each batch manufactured. Design Factor 4:1.
- Fatigue rated to 20,000 cycles at 1.5 times the WLL.
- Tempering temperature minimum 400°C
- Magnaflux crack detection is performed 100% on each batch.



X-P026
For load pin replacement



8-P025T
For trigger replacement

G-100 Clevis Self Locking Hook

Item No.	For Grade 100 Chain		WLL		Dimensions (inch)					N.W.
	inch	lbs*	tonnes*	A	H	K	P	T	lbs	
X-026-06	7/32	3,200	1.4	0.27	0.87	3.66	1.10	0.59	1.1	
X-026-07	1/4-5/16	5,700	2.5	0.40	1.02	4.69	1.34	0.79	1.8	
X-026-10	3/8	8,800	4.0	0.48	1.34	5.5 9	1.73	1.02	3.3	
X-026-13	1/2	15,000	6.7	0.60	1.65	7.01	2.01	1.18	6.6	
X-026-16	5/8	22,600	10.0	0.73	2.20	8.39	2.36	1.42	12.5	
X-026-20	3/4	35,300	16.0	0.86	2.56	9.61	2.76	2.09	22.5	
X-026-22	7/8	42,700	19.0	0.99	2.80	10.75	3.15	1.93	24.0	

★ Design factor 4:1 proof tested and certified.

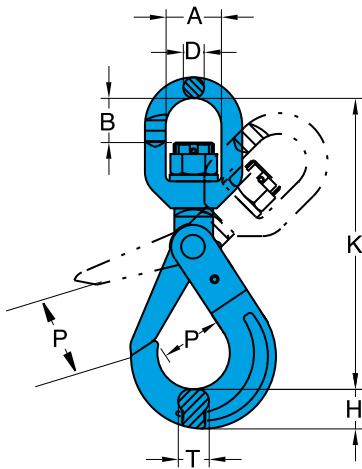

- Quenched and Tempered Alloy Steel.
- At least 25% greater WLL than traditional G80 products.
- Manufactured in accordance with EN 1677- 3 and ASME B30.26.
- Proof Load tested at 2.5 times the WLL with certification for each batch manufactured.
- Design Factor 4:1.
- Fatigue rated to 20,000 cycles at 1.5 times the WLL.
- Tempering temperature minimum 400°C
- Magnaflux crack detection is performed 100% on each batch.



8-P025T
For trigger

G-100 Swivel Self Locking Hook

With Brass Bushing

Item No.	For Grade 100 Chain			Dimensions (inch)						N.W. lbs
	inch	lbs*	tonnes*	A	D	H	K	P	T	
X-027-06	7/32	3,200	1.4	1.26	0.87	0.47	0.87	5.87	1.10	1.3
X-027-07	1/4-5/16	5,700	2.5	1.42	1.14	0.51	1.02	7.32	1.34	2.6
X-027-10	3/8	8,800	4.0	1.61	1.34	0.63	1.34	8.58	1.73	4.4
X-027-13	1/2	15,000	6.7	1.81	1.69	0.83	1.65	10.87	2.01	9.0
X-027-16	5/8	22,600	10.0	2.40	1.97	0.91	2.20	12.95	2.36	15.0
X-027-20	3/4	35,300	16.0	2.91	3.23	0.98	2.56	15.24	2.76	27.8
X-027-22	7/8	42,700	19.0	3.82	3.74	1.30	2.80	17.99	3.15	39.6
X-027-26	1	59,700	26.5	4.84	4.53	2.01	3.11	21.06	3.90	69.3

★ Design factor 4:1 proof tested and certified.

⚠ WARNING INFORMATION: This hook is a positioning device and is not intended to rotate under load. For swivel hooks designed to rotate under load, see X-027N.

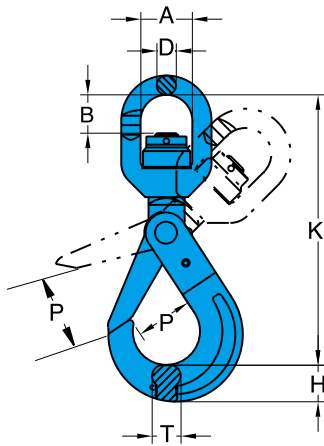

- Quenched and Tempered Alloy Steel.
- At least 25% greater WLL than traditional G80 products.
- Manufactured in accordance with EN 1677- 3 and ASME B30.26.
- Proof Load tested at 2.5 times the WLL with certification for each batch manufactured. Design Factor 4:1.
- Fatigue rated to 20,000 cycles at 1.5 times the WLL.
- Tempering temperature minimum 400°C
- Magnaflex crack detection is performed 100% on each batch.
- Built with ball bearing and enables full swivel feature under load.



8-P025T
For trigger

G-100 Swivel Self Locking Hook

with Ball Bearing, which performs full swivel under load.

Item No.	For Grade 100 Chain		Dimensions (inch)							N.W.
	inch	lbs*	tonnes*	A	D	H	K	P	T	lbs
X-027N-06	7/32	3,200	1.4	0.87	0.47	0.87	5.87	1.10	0.59	1.3
X-027N-07	1/4-5/16	5,700	2.5	1.14	0.51	1.02	7.32	1.34	0.79	2.6
X-027N-10	3/8	8,800	4.0	1.34	0.63	1.34	8.58	1.73	1.02	4.4
X-027N-13	1/2	15,000	6.7	1.69	0.83	1.65	10.87	2.01	1.18	9.0
X-027N-16	5/8	22,600	10.0	1.97	0.91	2.20	12.95	2.36	1.42	15.0
X-027N-20	3/4	35,300	16.0	3.23	0.98	2.56	15.24	2.76	2.09	27.8
X-027N-22	7/8	42,700	19.0	3.74	1.30	2.80	17.99	3.15	1.93	39.6
X-027N-26	1	59,700	26.5	4.53	2.01	3.11	21.06	3.90	2.20	69.3

★ Design factor 4:1 proof tested and certified.

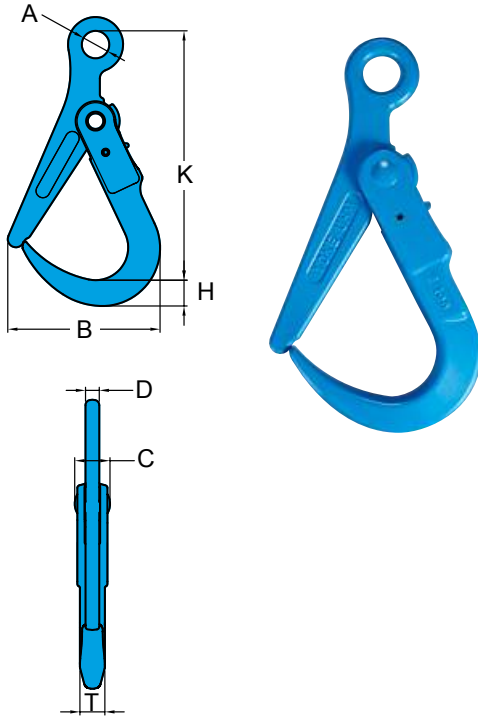

- Quenched and Tempered Alloy Steel.
- At least 25% greater WLL than traditional G80 products.
- Manufactured in accordance with EN 1677- 1 and ASME B30.26.
- Proof Load tested at 2.5 times the WLL with certification for each batch manufactured.
- Design Factor 4:1.
- Fatigue rated to 20,000 cycles at 1.5 times the WLL.
- Tempering temperature minimum 400°C

G-100 Super Lock Hook

Item No.	WLL		Dimensions (inch)								N.W.
	lbs	tonnes	A	B	C	D	H	K	P	T	lbs
X-019-02	4400	2.0	1.26	6.97	1.61	0.63	1.18	11.42	4.25	1.14	7.7
X-019-03	6600	3.0	1.26	6.97	1.61	0.63	1.18	11.42	4.25	1.14	7.7

★ Design factor 4:1 proof tested and certified.

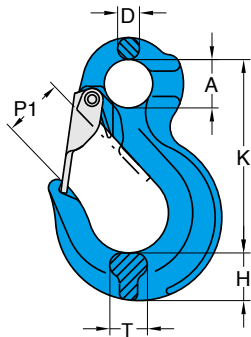

- Quenched and Tempered Alloy Steel.
- At least 25% greater WLL than traditional G80 products.
- Manufactured in accordance with EN 1677- 2 and ASME B30.26.
- Proof Load tested at 2.5 times the WLL with certification for each batch manufactured.
- Design Factor 4:1.
- Fatigue rated to 20,000 cycles at 1.5 times the WLL.
- Tempering temperature minimum 400°C
- Magnaflux crack detection is performed 100% on each batch.



8-P044
Repair kit available

G-100 Eye Sling Hook

with Latch

Item No.	For Grade 100 Chain	Working Load Limit		Dimensions (inch)						N.W.
		lbs*	tonnes*	A	D	H	K	P	T	
X-044/S-06	7/32	3,200	1.4	0.79	0.39	0.75	3.15	0.91	0.67	0.7
X-044/S-07	1/4-5/16	5,700	2.5	0.98	0.47	0.91	3.86	1.10	0.79	1.1
X-044/S-10	3/8	8,800	4.0	1.26	0.59	1.22	4.76	1.42	0.91	2.2
X-044/S-13	1/2	15,000	6.7	1.57	0.71	1.50	5.98	1.58	1.06	4.0
X-044/S-16	5/8	22,600	10.0	1.97	0.87	1.77	7.28	1.73	1.26	6.8
X-044/S-20	3/4	35,300	16.0	2.44	1.06	2.51	9.05	2.13	1.89	16.0
X-044/S-22	7/8	42,700	19.0	2.01	1.22	2.48	9.65	2.99	2.05	20.5
X-044/S-26	1	59,700	26.5	2.56	1.38	3.07	11.22	3.03	2.36	28.6
X-044/S-32	1-1/4	90,400	40.0	3.45	1.57	3.15	13.86	4.49	2.56	37.4

★ Design factor 4:1 proof tested and certified.

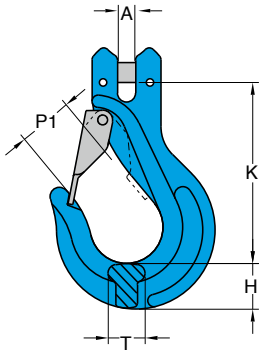

- Quenched and Tempered Alloy Steel.
- At least 25% greater WLL than traditional G80 products.
- Manufactured in accordance with EN 1677- 2 and ASME B30.26.
- Proof Load tested at 2.5 times the WLL with certification for each batch manufactured.
- Design Factor 4:1.
- Fatigue rated to 20,000 cycles at 1.5 times the WLL.
- Tempering temperature minimum 400°C
- Magnaflux crack detection is performed 100% on each batch.



X-P026
For load pin replacement



8-P044
For latch replacement

G-100 Clevis Sling Hook

with Latch

Item No.	Working Load Limit		For Grade 100 Chain inch	Dimensions (inch)						N.W. lbs
	lbs*	tonnes*		A	H	K	P1	T	T	
X-043/S-06	3,200	1.4	7/32	0.24	0.91	3.82	0.91	0.59	0.67	0.7
X-043/S-07	5,700	2.5	1/4-5/16	0.35	0.87	3.86	1.06	0.71	0.79	1.1
X-043/S-10	8,800	4.0	3/8	0.43	1.18	4.80	1.34	0.94	0.91	2.2
X-043/S-13	15,000	6.7	1/2	0.55	1.46	5.79	1.73	1.18	1.06	4.0
X-043/S-16	22,600	10.0	5/8	0.67	1.65	6.54	1.89	1.54	1.26	6.8
X-043/S-20	35,300	16.0	3/4	0.94	2.52	8.15	2.24	1.89	1.89	16.0
X-043/S-22	7/8	42,700	19.0	2.01	1.22	2.48	9.65	2.99	2.05	20.5

★ Design factor 4:1 proof tested and certified.

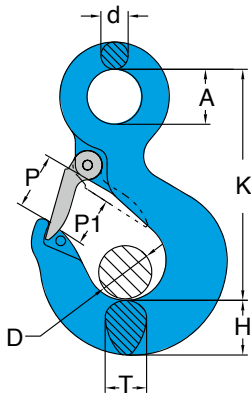

- Quenched and Tempered Alloy Steel.
- At least 25% greater WLL than traditional G80 products.
- Manufactured in accordance with EN 1677- 2 and ASME B30.26.
- Proof Load tested at 2.5 times the WLL with certification for each batch manufactured.
- Design Factor 4:1.
- Fatigue rated to 20,000 cycles at 1.5 times the WLL.
- Tempering temperature minimum 400°C
- Magnaflux crack detection is performed 100% on each batch.

G-100 Alloy Eye Hoist Hook

with Latch



For latch replacement

Item No.	Hook Feature Code	For Grade 100 Chain		For Grade 100 Chain inch	Dimensions (inch)								N.W. lbs
		lbs	tonnes*		A	D	d	H	K	P	P1	T	
8-173-015	BB	3,200	1.4	7/32	0.91	0.75	0.43	0.83	3.74	0.95	0.75	0.67	0.9
8-173-02	CC	5,700	2.5	1/4-5/16	1.14	0.79	0.51	1.02	4.17	1.06	0.79	0.83	1.5
8-173-03	DD	8,800	4.0	3/8	1.26	0.98	0.59	1.14	4.80	1.22	0.98	0.95	2.0
8-173-05	EE	15,000	6.7	1/2	1.57	1.22	0.71	1.46	5.87	1.42	1.22	1.22	4.6
8-173-07	FF	22,600	10.0	5/8	2.00	1.54	0.95	1.85	7.56	1.77	1.54	1.46	8.8
8-173-11	GG	35,300	16.0	3/4	2.44	2.24	1.10	2.28	9.13	2.40	2.24	1.89	15.2
8-173-15	HH	42,700	19.0	7/8	2.84	2.44	1.26	2.60	10.10	2.83	2.44	2.20	22.0

★ Design factor 4:1 proof tested and certified.

⚠
When using hoist hook with grade 100 chain, YOKE hoist hook is recommended to be grinded the WLL (which is for a safety factor 5:1) off the hook.

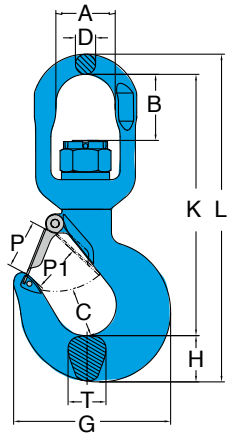

- Quenched and Tempered Alloy Steel.
- At least 25% greater WLL than traditional G80 products.
- Manufactured in accordance with EN 1677- 2 and ASME B30.26.
- Proof Load tested at 2.5 times the WLL with certification for each batch manufactured.
- Design Factor 4:1.
- Fatigue rated to 20,000 cycles at 1.5 times the WLL.
- Tempering temperature minimum 400°C
- Magnaflux crack detection is performed 100% on each batch.

G-100 Alloy Swivel Hoist Hook

with Brass Washer

Item No.	Hook Feature Code	Working Load Limit		For Grade 100 Chain	Dimensions (inch)											N.W. lbs
		lbs*	tonnes*		inch	A	B	C	D	G	H	K	L	P	P1	
8-175-015	BB	3,200	1.4	7/32	1.26	0.91	0.97	0.45	3.15	0.84	4.96	6.23	0.95	0.75	0.71	1.5
8-175-02	CC	5,700	2.5	1/4-5/16	1.42	1.14	1.03	0.49	3.66	1.00	5.63	7.15	1.06	0.79	0.88	2.0
8-175-03	DD	8,800	4.0	3/8	1.62	1.38	1.16	0.63	4.02	1.13	7.73	8.36	1.22	0.98	0.95	3.3
8-175-05	EE	15,000	6.7	1/2	1.83	1.73	1.53	0.83	5.14	1.41	8.32	10.58	1.42	1.22	1.22	7.0
8-175-07	FF	22,600	10.0	5/8	2.40	1.99	1.94	0.89	6.60	1.82	10.18	12.92	1.77	1.54	1.42	12.5
8-175-11	GG	35,300	16.0	3/4	2.92	3.25	2.46	0.99	7.72	2.28	12.84	16.11	2.40	2.24	1.89	21.2
8-175-15	HH	42,700	19.0	7/8	3.83	3.78	2.59	1.30	8.70	2.53	14.64	18.55	2.83	2.44	2.20	35.1

⚠ When using hoist hook with grade 100 chain, YOKE hoist hook is recommended to be grinded the WLL (which is for a safety factor 5:1) off the hook.

⚠ WARNING INFORMATION: This hook is a positioning device and is not intended to rotate under load. For swivel hooks designed to rotate under load, see 8-175N.

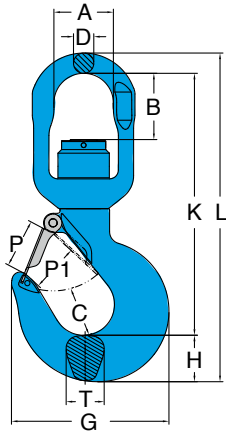

- Quenched and Tempered Alloy Steel.
- At least 25% greater WLL than traditional G80 products.
- Manufactured in accordance with EN 1677- 2 and ASME B30.26.
- Proof Load tested at 2.5 times the WLL with certification for each batch manufactured.
- Design Factor 4:1.
- Fatigue rated to 20,000 cycles at 1.5 times the WLL.
- Tempering temperature minimum 400°C
- Magnaflux crack detection is performed 100% on each batch.
- Built with ball bearing and enables full swivel feature under load.

G-100 Alloy Swivel Bearing Hoist Hook

with Ball Bearing, which performs full swivel under load.

Item No.	Hook Feature Code	Working Load Limit		For Grade 100 Chain inch	Dimensions (inch)										N.W. lbs	
		lbs*	tonnes*		A	B	C	D	G	H	K	L	P	P1		T
8-175N-015	BB	3,200	1.4	7/32	1.26	0.91	0.97	0.45	3.15	0.84	4.96	6.23	0.95	0.75	0.71	1.5
8-175N-02	CC	5,700	2.5	1/4-5/16	1.42	1.14	1.03	0.49	3.66	1.00	5.63	7.15	1.06	0.79	0.88	2.0
8-175N-03	DD	8,800	4.0	3/8	1.62	1.38	1.16	0.63	4.02	1.13	7.73	8.36	1.22	0.98	0.95	3.3
8-175N-05	EE	15,000	6.7	1/2	1.83	1.73	1.53	0.83	5.14	1.41	8.32	10.58	1.42	1.22	1.22	7.0
8-175N-07	FF	22,600	10.0	5/8	2.40	1.99	1.94	0.89	6.60	1.82	10.18	12.92	1.77	1.54	1.42	12.5
8-175N-11	GG	35,300	16.0	3/4	2.92	3.25	2.46	0.99	7.72	2.28	12.84	16.11	2.40	2.24	1.89	21.2
8-175N-15	HH	42,700	19.0	7/8	3.83	3.78	2.59	1.30	8.70	2.53	14.64	18.55	2.83	2.44	2.20	36.3



When using hoist hook with grade 100 chain, YOKE hoist hook is recommended to be grinded the WLL (which is for a safety factor 5:1) off the hook.

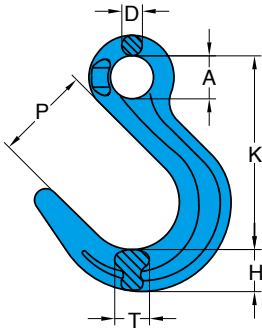

- Quenched and Tempered Alloy Steel.
- At least 25% greater WLL than traditional G80 products.
- Testing according to DIN PAS 1061 and ASTM A952/A 952M
- Proof Load tested at 2.5 times the WLL with certification for each batch manufactured.
- Design Factor 4:1.
- Fatigue rated to 20,000 cycles at 1.5 times the WLL.
- Tempering temperature minimum 400°C
- Not used for general chain sling applications, rather for use where a large throat opening is necessary.
- Before using the hook, check whether hooks without safety latches are allowed to be used for the particular application.

G-100 Eye Foundry Hook

Item No.	Working Load Limit		For Grade 100 Chain	Dimensions (inch)						N.W.
	lbs*	tonnes*		inch	A	D	H	K	P	
X-047-07	5,700	2.5	1/4-5/16	0.94	0.47	1.06	4.84	2.44	0.75	1.8
X-047-10	8,800	4.0	3/8	1.26	0.59	1.26	5.87	2.91	0.91	3.5
X-047-13	15,000	6.7	1/2	1.57	0.75	1.54	7.09	3.46	1.26	5.5
X-047-16	22,600	10.0	5/8	1.97	0.98	1.85	8.39	3.86	1.61	9.7
X-047-20	35,300	16.0	3/4	2.36	1.02	2.24	9.76	4.45	1.81	20.5

★ Design factor 4:1 proof tested and certified.

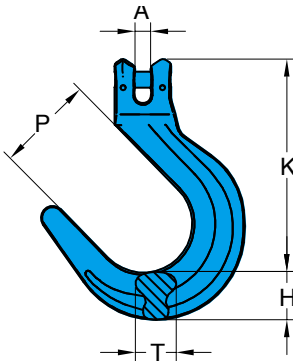

- Quenched and Tempered Alloy Steel.
- At least 25% greater WLL than traditional G80 products.
- Testing according to DIN PAS 1061 and ASTM A952/A 952M
- Design Factor 4:1.
- Fatigue rated to 20,000 cycles at 1.5 times the WLL.
- Tempering temperature minimum 400°C
- Designed for the assembly of chain slings where wide throat openings are necessary.
- Before using the hook, check whether hooks without safety latches are allowed to be used for the particular application.



X-P026
For load pin replacement

G-100 Clevis Foundry Hook

Item No.	Working Load Limit		For Grade 100 Chain inch	Dimensions (inch)					N.W. lbs
	lbs*	tonnes*		A	H	K	P	T	
X-046-07	5,700	2.5	1/4-5/16	0.35	1.06	5.24	2.44	0.75	2.1
X-046-10	8,800	4.0	3/8	0.43	1.26	6.42	2.91	0.91	4.0
X-046-13	15,000	6.7	1/2	0.55	1.54	7.87	3.46	1.26	7.9
X-046-16	22,600	10.0	5/8	0.71	1.85	9.41	3.86	1.61	14.1
X-046-20	35,300	16.0	3/4	0.83	2.44	12.01	4.45	1.81	24.6

★ Design factor 4:1 proof tested and certified.

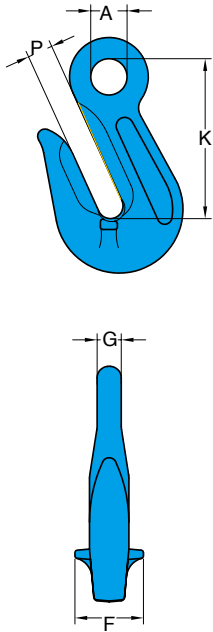

- Quenched and Tempered Alloy Steel.
- At least 25% greater WLL than traditional G80 products.
- Testing according to DIN PAS 1061 and ASTM A952/A 952M
- Proof Load tested at 2.5 times the WLL with certification for each batch manufactured.
- Design Factor 4:1.
- Fatigue rated to 20,000 cycles at 1.5 times the WLL.
- Tempering temperature minimum 400°C
- Not for use with Omega Link
- Enables full WLL while in use, thanks to supporting wings which prevent chain link deformation.

G-100 Eye Grab Hook

Item No.	Working Load Limit		For Grade 100 Chain inch	Dimensions (inch)					N.W. lbs
	lbs*	tonnes*		A	F	G	K	P	
X-041-06	3,200	1.4	7/32	0.51	1.02	0.31	1.97	0.31	0.2
X-041-07	5,700	2.5	1/4-5/16	0.63	1.18	0.35	2.44	0.39	0.7
X-041-10	8,800	4.0	3/8	0.79	1.57	0.51	3.23	0.51	1.3
X-041-13	15,000	6.7	1/2	1.02	2.05	0.63	4.21	0.67	3.1
X-041-16	22,600	10.0	5/8	1.18	2.24	0.79	5.19	0.83	5.3
X-041-20	35,300	16.0	3/4	1.50	2.87	0.94	5.79	0.91	8.8
X-041-22	42,700	19.0	7/8	1.50	2.76	1.02	6.46	1.02	10.1
X-041-26	58,400	26.5	26	1.97	4.33	1.26	8.15	1.3	22.0

★ Design factor 4:1 proof tested and certified.

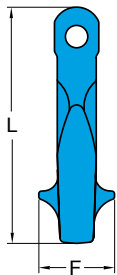
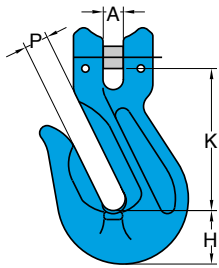

- Quenched and Tempered Alloy Steel.
- At least 25% greater WLL than traditional G80 products.
- Testing according to DIN PAS 1061 and ASTM A952/A 952M
- Proof Load tested at 2.5 times the WLL with certification for each batch manufactured.
- Design Factor 4:1.
- Fatigue rated to 20,000 cycles at 1.5 times the WLL.
- Tempering temperature minimum 400°C
- Not for use with Omega Link
- Enables full WLL while in use, thanks to supporting wings which prevent chain link deformation.



X-P026

For load pin replacement

G-100 Clevis Grab Hook

Item No.	Working Load Limit		For Grade 100 Chain	Dimensions (inch)						N.W.
	lbs*	tonnes*	inch	A	F	H	K	L	P	lbs
X-042-06	3,200	1.4	7/32	0.28	0.98	0.71	1.85	3.11	0.32	0.4
X-042-07	5,700	2.5	1/4-5/16	0.39	1.18	0.87	2.17	3.66	0.39	0.9
X-042-10	8,800	4.0	3/8	0.43	1.61	1.14	3.03	5.04	0.51	1.7
X-042-13	15,000	6.7	1/2	0.59	2.05	1.50	3.90	6.50	0.67	3.5
X-042-16	22,600	10.0	5/8	0.71	2.24	1.77	4.49	7.68	0.83	6.0
X-042-20	35,300	16.0	3/4	0.87	2.87	2.05	5.12	8.74	0.91	9.9
X-042-22	42,700	19.0	22	0.98	1.65	2.20	5.47	9.72	1.06	13.9

★ Design factor 4:1 proof tested and certified.

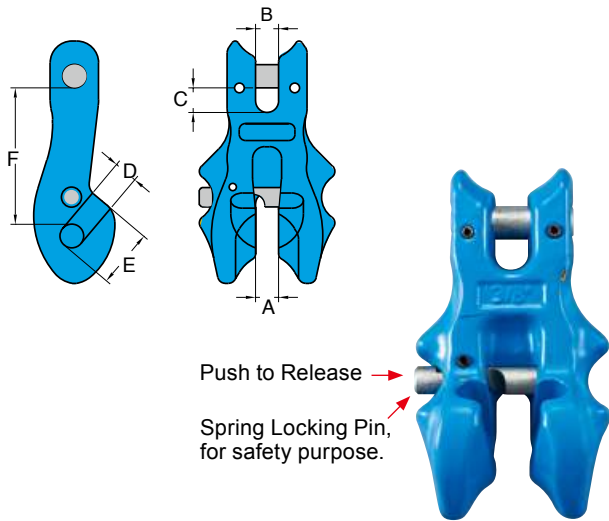

- Quenched and Tempered Alloy Steel.
- At least 25% greater WLL than traditional G80 products.
- Manufactured in accordance with EN 1677- 1 and ASME B30.26.
- Proof Load tested at 2.5 times the WLL with certification for each batch manufactured.
- Design Factor 4:1.
- Fatigue rated to 20,000 cycles at 1.5 times the WLL.
- Tempering temperature minimum 400°C
- The use of Clevis Clutch still allows 100% of the chain sling capacity.

G-100 Clevis Clutch - Locking Type

Item No.	For Chain		WLL		Dimensions (inch)						N.W.
	inch		lbs	tonnes	A	B	C	D	E	F	lbs
X-061-06	7/32		3,200	1.4	0.28	0.39	0.28	0.71	1.97	0.01	0.7
X-061-07	1/4-5/16		5,700	2.5	0.39	0.39	0.39	0.94	2.20	0.02	1.1
X-061-10	3/8		8,800	4.0	0.47	0.47	0.47	1.10	2.60	0.04	2.0
X-061-13	1/2		15,000	6.7	0.59	0.63	0.63	1.54	3.46	0.09	4.8
X-061-16	5/8		22,600	10.0	0.83	0.75	0.75	1.89	4.06	0.15	8.1
X-061-20	3/4		35,300	16.0	0.91	0.91	0.83	2.17	5.20	0.23	12.8

★ Design factor 4:1 proof testes and certificated.

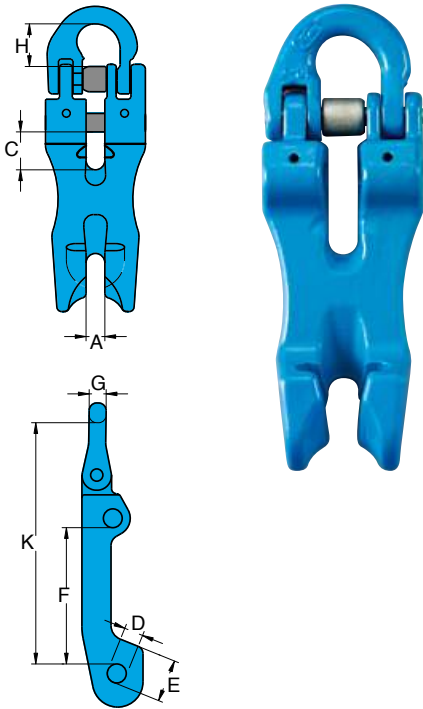

- Quenched and Tempered Alloy Steel.
- At least 25% greater WLL than traditional G80 products.
- Manufactured in accordance with EN 1677- 1 and ASME B30.26.
- Proof Load tested at 2.5 times the WLL with certification for each batch manufactured.
- Design Factor 4:1.
- Fatigue rated to 20,000 cycles at 1.5 times the WLL.
- Tempering temperature minimum 400°C
- Dual locking pins that provide safer locking mechanism.
- Simple assembling and disassembling without special tool required.

G-100 Shortening Clutch

Item No.	For Chain	WLL		Dimensions (inch)								N.W.
		inch	lbs	tonnes	A	C	D	E	F	H	G	
X-078-07	1/4-5/16	5,700	2.5	0.47	0.79	0.39	0.91	2.76	0.89	0.35	5.04	1.5
X-078-10	3/8	8,800	4.0	0.51	1.02	0.47	1.14	3.43	1.06	0.50	6.06	2.9
X-078-13	1/2	15,000	6.7	0.59	1.30	0.63	1.46	4.53	1.38	0.62	7.99	6.2
X-078-16	5/8	22,600	10.0	0.83	1.54	0.75	1.81	5.63	1.51	0.75	9.76	11.7

★ Design factor 4:1 proof testes and certificated.



Safety is our first priority™

www.yoke.net



Quality approval by:



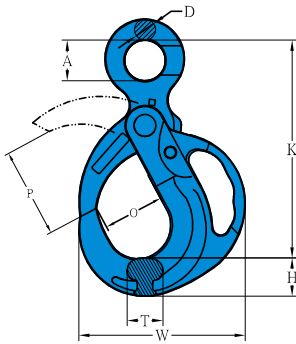

- Quenched and Tempered Alloy Steel.
 - Manufactured in accordance with EN 1677- 1.
 - Testing according to ASTM A952/A-DIN PAS 1061.
 - Proof Load tested at 2.5 times the WLL with certification for each batch manufactured.
 - Design Factor 4:1.
 - Fatigue rated to 20,000 cycles at 1.5 times the WLL.
 - Tempering temperature minimum 400°C
- » American Patent



8-P950
For push lock replacement

G-100 Eye Grip Safe Locking Hook

Item No.	Working Load Limit		For Grade 100 Chain	Dimensions (inch)								N.W. lbs
	lbs*	tonnes*		inch	A	D	H	K	O	P	T	
X-950-10	8,800	4.0	3/8	1.26	0.51	1.22	6.89	1.93	2.80	1.06	5.47	4.2
X-950-13	15,000	6.7	1/2	1.57	0.63	1.54	8.94	2.24	3.15	1.34	6.85	6.6
X-950-16	22,600	10.0	5/8	1.97	0.83	1.85	10.91	3.07	4.49	1.54	8.35	13.9
X-950-20	35,300	16.0	3/4	2.36	0.91	2.20	12.95	3.58	5.00	2.13	9.84	25.8
X-950-22	42,700	19.0	7/8	2.76	0.94	2.32	13.78	4.13	5.94	2.20	10.24	31.9

★ Design factor 4:1 proof tested and certified

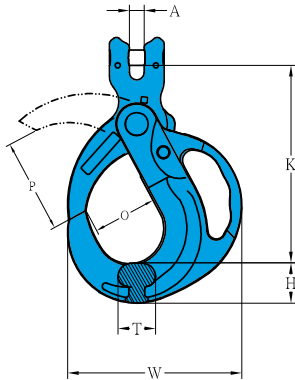

- Quenched and Tempered Alloy Steel.
- Manufactured in accordance with EN 1677- 1.
- Testing according to ASTM A952/A-DIN PAS 1061.
- Proof Load tested at 2.5 times the WLL with certification for each batch manufactured.
- Fatigue rated to 20,000 cycles at 1.5 times the WLL.
- Tempering temperature minimum 400°C

» American Patent



8-P950

For push lock replacement

G-100 Clevis Grip Safe Locking Hook

Item No.	Working Load Limit		For Grade 100 Chain	Dimensions (inch)							N.W. lbs
	lbs*	tonnes*		inch	A	H	K	O	P	T	
X-951-10	8,800	4.0	3/8	0.43	1.22	6.02	1.93	2.80	1.06	5.47	4.2
X-951-13	15,000	6.7	1/2	0.55	1.54	8.11	2.24	3.15	1.34	6.85	9.0
X-951-16	22,600	10.0	5/8	0.71	1.85	9.57	3.07	4.49	1.54	8.35	14.1
X-951-20	35,300	16.0	3/4	0.83	2.20	12.20	3.58	5.00	2.13	9.84	28.0
X-951-22	42,700	19.0	7/8	0.94	2.32	11.81	4.13	5.94	2.20	10.24	31.1

★ Design factor 4:1 proof tested and certified

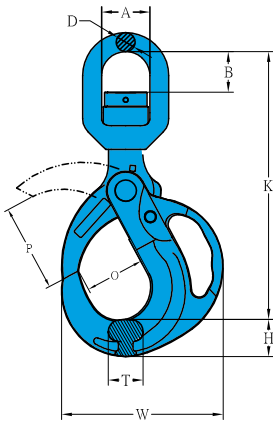

- Quenched and Tempered Alloy Steel.
 - Manufactured in accordance with EN 1677- 1.
 - Testing according to ASTM A952/A-DIN PAS 1061.
 - Proof Load tested at 2.5 times the WLL with certification for each batch manufactured.
 - Design Factor 4:1.
 - Fatigue rated to 20,000 cycles at 1.5 times the WLL.
 - Tempering temperature minimum 400°C
 - Built with ball bearing and enables full swivel feature under load.
- » American Patent

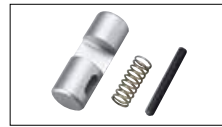

8-P950
For push lock replacement

G-100 Swivel Grip Safe Locking Hook

Item No.	Working Load Limit		For Grade 100 Chain	Dimensions (inch)									N.W. lbs
	lbs*	tonnes*		inch	A	B	D	H	K	O	P	T	
X-952N-10	8,800	4.0	3/8	1.61	1.34	0.63	1.22	8.86	1.93	2.80	1.06	5.47	5.3
X-952N-13	15,000	6.7	1/2	1.81	1.73	0.83	1.54	11.22	2.24	3.15	1.34	6.85	11.4
X-952N-16	22,600	10.0	5/8	2.40	1.97	0.91	1.85	13.58	3.07	4.49	1.54	8.35	18.5
X-952N-20	35,300	16.0	3/4	2.91	3.23	0.98	2.20	17.05	3.58	5.00	2.13	9.84	31.9
X-952N-22	42,700	19.0	7/8	3.82	3.74	1.30	2.32	18.70	4.13	5.94	2.20	10.24	43.8

★ Design factor 4:1 proof tested and certified

★ Design factor 4:1 proof tested and certified

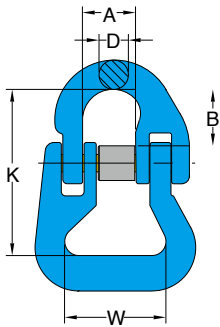

- Quenched and Tempered Alloy Steel.
- At least 25% greater WLL than traditional G80 products.
- Manufactured in accordance with EN 1677- 1 and ASME B30.26.
- Proof Load tested at 2.5 times the WLL with certification for each batch manufactured.
- Design Factor 4:1.
- Fatigue rated to 20,000 cycles at 1.5 times the WLL.
- Tempering temperature minimum 400°C

G-100 Web Sling Connector

Item No.	Working Load Limit		For Grade 100 Chain	Dimensions (inch)					N.W.
	lbs*	tonnes*	inch	A	B	D	K	W	lbs
X-016-06	3,200	1.4	7/32	0.59	0.67	0.28	2.16	1.54	0.4
X-016-07	5,700	2.5	1/4-5/16	0.71	0.89	0.35	2.44	1.57	0.7
X-016-10	8,800	4.0	3/8	0.99	1.06	0.50	3.07	1.85	1.3
X-016-13	15,000	6.7	1/2	1.19	1.38	0.62	3.74	2.09	2.4
X-016-16	22,600	10.0	5/8	1.42	1.51	0.75	4.53	2.64	4.4
X-016-20	35,300	16.0	3/4	1.65	1.81	0.87	5.20	3.15	7.0
X-016-22	42,700	19.0	7/8	1.93	2.32	0.94	7.36	4.92	16.3

★ Design factor 4:1 proof tested and certified.

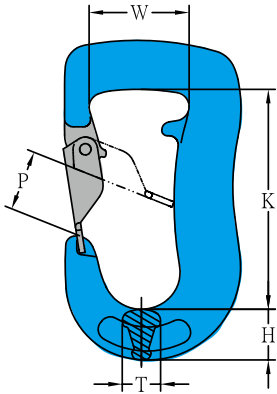

- Quenched and Tempered Alloy Steel.
- At least 25% greater WLL than traditional G80 products.
- Manufactured in accordance with EN 1677- 1 and ASME B30.26.
- Proof Load tested at 2.5 times the WLL with certification for each batch manufactured.
- Design Factor 4:1.
- Fatigue rated to 20,000 cycles at 1.5 times the WLL.
- Tempering temperature minimum 400°C

G-100 Web Sling Hook

Item No.	Working Load Limit		Dimensions (inch)					N.W.
	lbs*	tonnes*	H	K	P	T	W	lbs
X-032-01	2,200	1	0.79	3.50	0.98	0.59	1.69	1.5
X-032-02	4,400	2	1.06	4.57	1.18	0.79	2.09	3.3
X-032-03	6,600	3	1.26	4.69	1.26	1.02	2.52	5.3
X-032-05	11,000	5	1.73	5.71	1.77	1.50	2.40	7.7

★ Design factor 5:1 proof tested and certified.

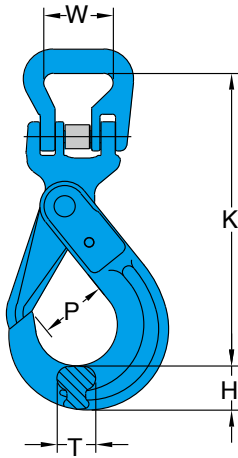

- Quenched and Tempered Alloy Steel.
- At least 25% greater WLL than traditional G80 products.
- Manufactured in accordance with ASTM A906/A906M, ASTM A952/A952M, ASME B30.9, ASME B30.10, ASME B30.26 and OSHA 1910.184.
- Proof Load tested at 2.5 times the WLL with certification for each batch manufactured.
- Design Factor 4:1.
- Fatigue rated to 20,000 cycles at 1.5 times the WLL.
- Tempering temperature minimum 400°C



8-P025T
for trigger

G-100 Round Sling Self Locking Hook

Item No.	Working Load Limit		For Grade 100 Chain inch	Dimensions (inch)					N.W. lbs
	lbs*	tonnes*		H	K	P	T	W	
X-028-06	3,200	1.4	7/32	0.75	5.43	1.14	0.59	1.54	1.3
X-028-07	5,700	2.5	1/4-5/16	0.94	6.65	1.34	0.79	1.57	2.4
X-028-10	8,800	4.0	3/8	1.19	7.72	1.77	1.02	1.85	4.0
X-028-13	15,000	6.7	1/2	1.57	9.96	2.13	1.19	2.09	8.6
X-028-16	22,600	10.0	5/8	1.93	12.00	2.44	1.42	2.64	15.2
X-028-20	35,300	16.0	3/4	2.36	12.91	3.54	1.91	3.15	26.4
X-028-22	42,700	19.0	7/8	2.48	16.38	3.14	2.12	4.92	40.9

★ Design factor 4:1 proof tested and certified.

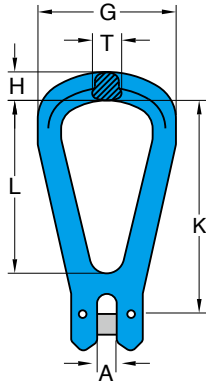

- Quenched and Tempered Alloy Steel.
- At least 25% greater WLL than traditional G80 products.
- Manufactured in accordance with EN 1677- 1 and ASME B30.26.
- Proof Load tested at 2.5 times the WLL with certification for each batch manufactured.
- Design Factor 4:1.
- Fatigue rated to 20,000 cycles at 1.5 times the WLL.
- tempering temperature minimum 400°C

G-100 Clevis Master Link

Item No.	Working Load Limit		For Grade 100 Chain inch	Dimensions (inch)						N.W. lbs
	lbs*	tonnes*		A	G	H	K	L	T	
X-059-07	5,700	2.5	1/4-5/16	0.35	2.56	0.59	3.90	3.15	0.59	0.9
X-059-10	8,800	4.0	3/8	0.43	3.15	0.71	4.92	3.94	0.75	1.8
X-059-13	15,000	6.7	1/2	0.55	4.25	0.87	6.61	5.35	0.98	3.3
X-059-16	22,600	10.0	5/8	0.71	4.88	1.02	7.80	6.22	1.06	5.3

★ Design factor 4:1 proof tested and certified

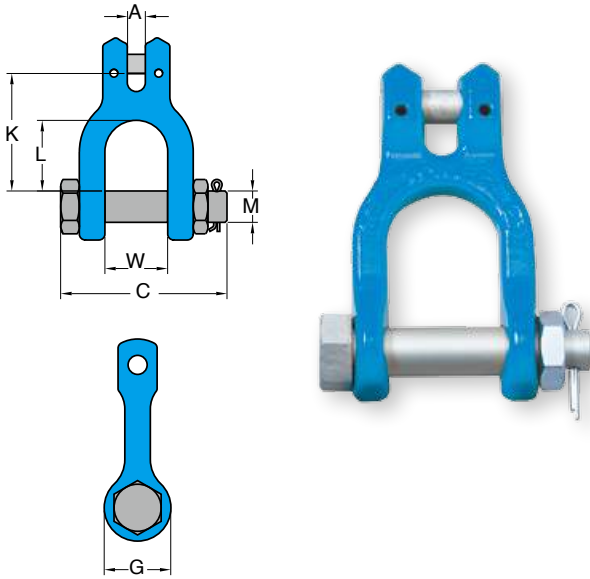

- Quenched and Tempered Alloy Steel.
- At least 25% greater WLL than traditional G80 products.
- Manufactured in accordance with EN 1677- 1 and ASME B30.26.
- Proof Load tested at 2.5 times the WLL with certification for each batch manufactured.
- Design Factor 4:1.
- Fatigue rated to 20,000 cycles at 1.5 times the WLL.
- Tempering temperature minimum 400°C

G-100 Clevis Shackle

Item No.	Working Load Limit		For Grade 100 Chain inch	Dimensions (inch)							N.W. lbs
	lbs*	tonnes*		A	C	G	K	L	M	W	
X-066-07	5,700	2.5	1/4-5/16	0.35	3.11	1.34	2.32	1.38	0.63	1.30	0.9
X-066-10	8,800	4.0	3/8	0.43	3.66	1.57	3.07	1.89	0.79	1.46	1.8
X-066-13	15,000	6.7	1/2	0.55	4.65	1.73	3.86	2.52	0.87	1.93	3.1
X-066-16	22,600	10.0	5/8	0.71	5.55	2.13	4.41	2.72	1.10	2.36	5.5

★ Design factor 4:1 proof tested and certified



DISCOVERY VIDEO



Oblong Master Link, Code "MF".

Connected to Chain with "YA" connecting link.

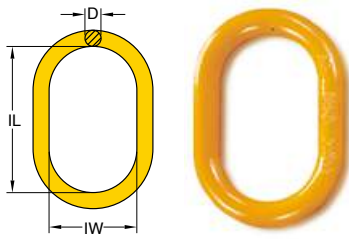

Extra width inside allows better works on large crane hooks.



Type Approval

Item No.	Trade Size	For Grade 80 Chain(inch)		Working Load Limit		Dimensions (inch)			N.W. lbs
		1-Leg	2-Leg	lbs*	tonnes*	D	IL	IW	
8-003-06 ※	3/8	7/32	--	3,000	1.25	0.43	3.94	2.36	0.4
8-003-0806 ※	1/2	1/4-5/16	7/32	4,920	2.5	0.55	4.72	2.76	0.9
8-003-1008 ※	5/8	3/8	1/4-5/16	6,600	4.0	0.67	5.51	3.15	1.5
8-003-13 ※	3/4	1/2	--	10,320	5.4	0.75	5.91	3.54	2.4
8-003-1310 ※	7/8	1/2	3/8	14,040	7.5	0.87	6.30	3.74	3.3
8-003-16 ※	1	5/8	--	24,360	10.0	0.98	7.48	4.33	4.9
8-003-1613 ※	1-1/8	5/8	1/2	27,000	10.0	1.10	7.09	4.13	6.2
8-003-19 ※	1-1/4	3/4	--	35,160	12.0	1.18	7.87	4.72	8.4
8-003-2216 ※	1-3/8	7/8	5/8	42,000	17.0	1.34	9.45	5.51	12.1
8-003-26 ※	1-1/2	1	--	47,880	25.0	1.50	9.84	5.91	15.4
8-003-2619 ※	1-5/8	1	3/4	60,600	28.0	1.57	9.84	5.91	17.6
8-003-3222 ※	1-3/4	1-1/4	7/8	62,520	37.0	1.77	11.81	7.09	28.0

※ Forged Oblong Master Links.

Design factor 4:1 proof tested and certified Tested acc. to EN 1677

Oblong Master Link with Flat. Code "MFF"

Connected to Chain with "YO" Omega Link.

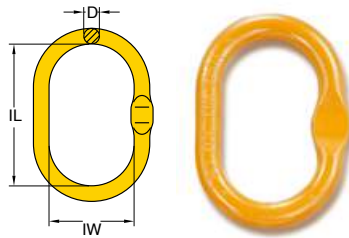

Item No.	Trade Size	For Grade 80 Chain(inch)		Working Load Limit		Dimensions (inch)			N.W. lbs
		1-Leg	2-Leg	lbs*	tonnes*	D	IL	IW	
8-003F-06 ※	3/8	7/32	--	3,000	1.25	0.43	3.94	2.36	0.4
8-003F-0806 ※	1/2	1/4-5/16	7/32	4,920	2.5	0.55	4.72	2.76	0.9
8-003F-1008 ※	5/8	3/8	1/4-5/16	6,600	4.0	0.67	5.51	3.15	1.5
8-003F-1310 ※	7/8	1/2	3/8	14,040	7.5	0.87	6.30	3.74	3.3
8-003F-1613 ※	1-1/8	5/8	1/2	27,000	10.0	1.10	7.09	4.13	5.9
8-003F-2216 ※	1-3/8	3/4	5/8	42,000	17.0	1.34	9.45	5.51	12.1
8-003F-2619 ※	1-5/8	1	3/4	60,600	28.0	1.57	9.84	5.91	17.4

※ Forged Oblong Master Links.

★ Design factor 4:1 Proof tested and certified

WLL=Working Load Limit Tested acc. to EN 1677

Clevis Master Link. Code "YG"

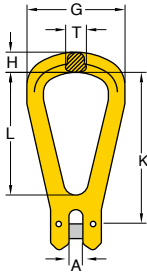

Item No.	Working Load Limit		For Grade 80 Chain	Dimensions (inch)						N.W.
	lbs*	tonnes*	inch	A	G	H	K	L	T	lbs
8-059-07	4,500	2.0	1/4-5/16	0.35	2.56	0.59	3.90	3.15	0.59	0.9
8-059-10	7,100	3.15	3/8	0.43	3.15	0.71	4.92	3.94	0.75	1.8
8-059-13	12,000	5.3	1/2	0.55	4.25	0.87	6.62	5.35	0.98	3.3
8-059-16	18,100	8.0	5/8	0.71	4.88	1.02	7.80	6.50	1.07	5.3

★ Design factor 4:1 proof tested and certified
Tested acc. to EN 1677

D Master Link. Code "DA"

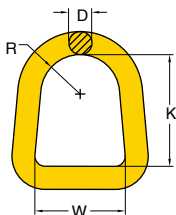

Item No.	Working Load Limit		Dimensions (inch)				N.W.
	lbs*	tonnes*	D	K	R	W	lbs
8-056-14	5,500	2.5	0.55	2.68	0.94	2.17	0.6
8-056-17	8,800	4.0	0.67	2.56	1.14	2.52	1.3
8-056-22	17,600	8.0	0.87	3.66	1.30	2.99	2.4
8-056-26	22,000	10.0	1.02	3.58	1.34	2.64	3.7
8-056-28	26,400	12.0	1.10	4.37	1.61	3.19	4.2
8-056-32	35,200	16.0	1.38	5.20	1.97	3.98	8.6
8-056-45	53,000	24.0	1.77	7.64	2.95	5.90	20.7

★ Design factor 5:1 Proof tested and certified
Tested acc. to EN 1677

**Connecting Link
Code " YA "**

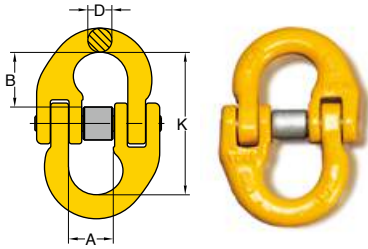

Item No.	Working Load Limit		For Grade 80 Chain	Dimensions (inch)				N.W.
	lbs*	tonnes*	inch	A	B	D	K	lbs
8-015-05	1,500	0.8	3/16	0.39	0.51	0.24	1.39	0.08
8-015-06	2,500	1.12	7/32	0.59	0.67	0.28	1.73	0.2
8-015-07	4,500	2.0	1/4-5/16	0.71	0.89	0.35	2.25	0.4
8-015-10	7,100	3.15	3/8	0.99	1.06	0.50	2.68	0.7
8-015-13	12,000	5.3	1/2	1.19	1.38	0.62	3.58	1.5
8-015-16	18,100	8.0	5/8	1.42	1.51	0.75	3.94	2.4
8-015-20	28,300	12.5	3/4	1.65	1.81	0.87	4.80	4.2
8-015-22	34,200	15.0	7/8	1.93	2.32	0.94	5.98	6.6
8-015-26	47,700	21.2	1	2.17	2.44	1.19	6.38	10.4
8-015-32	72,300	31.5	1-1/4	2.72	3.11	1.42	7.96	19.4

★ Design factor 4:1 proof tested and certified
Tested acc. to EN 1677

Connecting Link

Dacromet® Surface Finish.**



special pin and sleeve designed for more often re-use purpose.

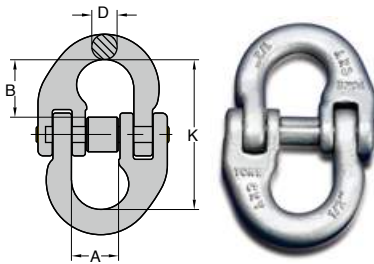

Item No.	Working Load Limit		For Grade 80 Chain	Dimensions (inch)				N.W.
	lbs*	tonnes*	inch	A	B	D	K	lbs
8-M015-05	1,500	0.8	3/16	0.39	0.51	0.24	1.39	0.08
8-M015-06	2,500	1.12	7/32	0.59	0.67	0.28	1.73	0.2
8-M015-07	4,500	2.0	1/4-5/16	0.71	0.89	0.35	2.25	0.4
8-M015-10	7,100	3.15	3/8	0.99	1.06	0.50	2.68	0.7
8-M015-13	12,000	5.3	1/2	1.19	1.38	0.62	3.58	1.5
8-M015-16	18,100	8.0	5/8	1.42	1.51	0.75	3.94	2.4
8-M015-20	28,300	12.5	3/4	1.65	1.81	0.87	4.80	4.2
8-M015-22	34,200	15.0	7/8	1.93	2.32	0.94	5.98	6.6
8-M015-26	47,700	21.2	1	2.17	2.44	1.19	6.38	10.4
8-M015-32	72,300	31.5	1-1/4	2.72	3.11	1.42	7.96	19.4

★ Design factor 4:1 proof tested and certified
Tested acc. to EN 1677

Omega Link. Code "YO"

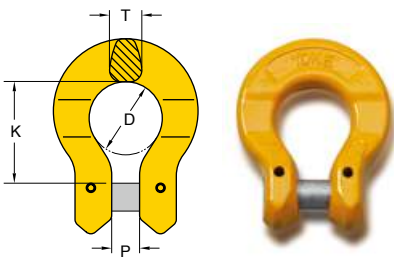

Item No.	Working Load Limit		For Grade 80 Chain	Dimensions (inch)				N.W.
	lbs*	tonnes*	inch	D	K	P	T	lbs
8-018-06	2,500	1.12	7/32	0.83	1.18	0.31	0.35	0.2
8-018-07	4,500	2.0	1/4-5/16	1.06	1.42	0.35	0.44	0.4
8-018-10	7,100	3.15	3/8	1.26	1.73	0.47	0.59	0.9
8-018-13	12,000	5.3	1/2	1.65	2.17	0.62	0.67	1.8
8-018-16	18,100	8.0	5/8	1.96	2.72	0.71	0.89	3.3
8-018-20	28,300	12.5	3/4	2.28	3.15	0.85	1.08	4.6

★ Design factor 4:1 proof tested and certified
Tested acc. to EN 1677



How to use YOKE Self Locking Hook?



Eye Self Locking Hook. Code "YC"

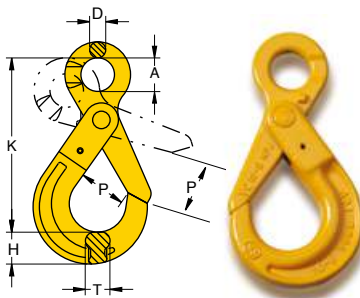

ABS
Type Approval

Item No.	Working Load Limit		For Grade 80 Chain inch	Dimensions (inch)						N.W. lbs
	lbs*	tonnes*		A	D	H	K	P	T	
8-025-06	2,500	1.12	7/32	0.83	0.39	0.75	4.33	1.14	0.59	1.1
8-025-07	4,500	2.0	1/4-5/16	0.98	0.44	0.94	5.35	1.34	0.79	1.8
8-025-10	7,100	3.15	3/8	1.26	0.51	1.19	6.57	1.77	1.02	3.1
8-025-13	12,000	5.3	1/2	1.56	0.62	1.57	8.15	2.13	1.19	6.4
8-025-16	18,100	8.0	5/8	2.05	0.83	1.93	9.92	2.44	1.42	12.6
8-025-20	28,300	12.5	3/4	2.52	0.91	2.36	11.10	3.54	1.91	18.7
8-025-22	34,200	15.0	7/8	2.75	0.94	2.48	12.56	3.14	2.12	27.6
8-025-26	47,700	21.2	1	3.15	0.98	2.72	13.50	3.90	2.20	32.0
8-025-28	55,100	24.8	1-1/8	3.54	1.10	3.18	15.80	4.72	2.48	54.9

★ Design factor 4:1 proof tested and certified
Tested acc. to EN 1677

Clevis Self Locking Hook. Code "YD"

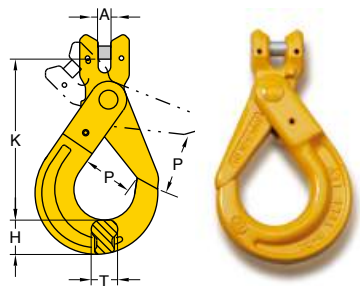

Item No.	Working Load Limit		For Grade 80 Chain inch	Dimensions (inch)					N.W. lbs
	lbs*	tonnes*		A	H	K	P	T	
8-026-06	2,500	1.12	7/32	0.24	0.75	3.94	1.14	0.59	1.1
8-026-07	4,500	2.0	1/4-5/16	0.35	0.94	4.69	1.34	0.79	1.8
8-026-10	7,100	3.15	3/8	0.43	1.19	5.63	1.77	1.02	3.1
8-026-13	12,000	5.3	1/2	0.55	1.57	7.05	2.13	1.19	6.4
8-026-16	18,100	8.0	5/8	0.71	1.93	8.35	2.44	1.42	12.4
8-026-20	28,300	12.5	3/4	0.83	2.36	9.56	3.54	1.91	19.4
8-026-22	34,200	15.0	7/8	0.95	2.48	10.70	3.14	2.12	28.2

★ Design factor 4:1 proof tested and certified
Tested acc. to EN 1677

Swivel Self Locking Hook. Code" YE "

with Brass Bushing

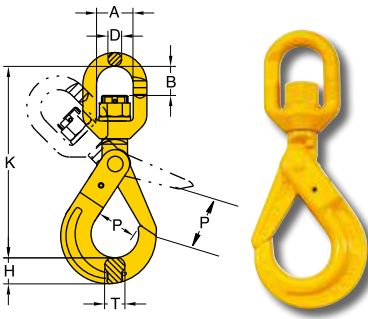

Item No.	Working Load Limit		For Grade 80 Chain inch	Dimensions (inch)							N.W. lbs
	lbs*	tonnes*		A	B	D	H	K	P	T	
8-027-06	2,500	1.12	7/32	1.26	0.87	0.44	0.75	5.86	1.14	0.59	1.5
8-027-07	4,500	2.0	1/4-5/16	1.42	1.14	0.51	0.94	7.32	1.34	0.79	2.6
8-027-10	7,100	3.15	3/8	1.63	1.34	0.62	1.19	8.66	1.77	1.02	4.4
8-027-13	12,000	5.3	1/2	1.81	1.70	0.83	1.57	10.51	2.09	1.19	9.0
8-027-16	18,100	8.0	5/8	2.36	1.97	0.91	1.93	12.91	2.44	1.42	15.9
8-027-20	28,300	12.5	3/4	2.91	3.23	1.02	2.36	15.28	3.54	1.91	24.9
8-027-22	34,200	15.0	7/8	3.82	3.74	1.30	2.48	17.99	3.14	2.12	39.5
8-027-26	47,700	21.2	1	4.13	4.53	1.65	2.72	21.06	3.90	2.20	62.4

★ Design factor 4:1 proof tested and certified
Tested acc. to EN 1677

⚠ **WARNING INFORMATION:** This hook is a positioning device and is not intended to rotate under load. For swivel hooks designed to rotate under load, see p.129 8-027N .

Swivel Self Locking Hook. Code "YEN"

with Ball Bearing, which performs full swivel underload

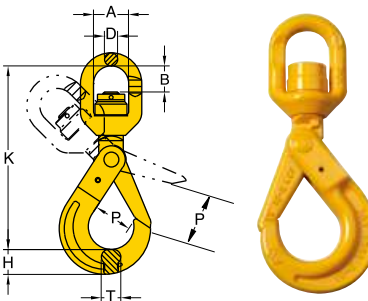

Item No.	Working Load Limit		For Grade 80 Chain inch	Dimensions (inch)							N.W. lbs
	lbs*	tonnes*		A	B	D	H	K	P	T	
8-027N-06	2,500	1.12	7/32	1.26	0.87	0.44	0.75	5.86	1.14	0.59	1.5
8-027N-07	4,500	2.0	1/4-5/16	1.42	1.14	0.51	0.94	7.32	1.34	0.79	2.6
8-027N-10	7,100	3.15	3/8	1.63	1.34	0.62	1.19	8.66	1.77	1.02	4.4
8-027N-13	12,000	5.3	1/2	1.81	1.70	0.83	1.57	10.51	2.09	1.19	9.0
8-027N-16	18,100	8.0	5/8	2.36	1.97	0.91	1.93	12.91	2.44	1.42	16.1
8-027N-20	28,300	12.5	3/4	2.91	3.23	1.02	2.36	15.28	3.54	1.91	25.1
8-027N-22	34,200	15.0	7/8	3.82	3.74	1.30	2.48	17.99	3.14	2.12	39.9
8-027N-26	47,700	21.2	1	4.13	4.53	1.65	2.72	21.06	3.90	2.20	65.0

★ Design factor 4:1 proof tested and certified
Tested acc. to EN 1677

Shank Self Locking Hook. Code "YEA"

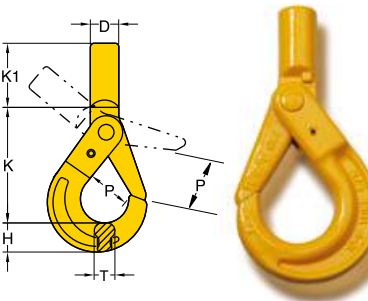

Item No.	Working Load Limit		Dimensions (inch)							N.W. lbs
	lbs*	tonnes*	D	d min.**	H	K	K1	P	T	
8-024-06	2,500	1.12	0.83	0.44	0.75	3.54	1.46	1.14	0.59	1.1
8-024-07	4,500	2.0	1.98	0.51	0.94	4.53	1.69	1.38	0.79	2.0
8-024-10	7,100	3.15	1.14	0.62	1.19	5.31	1.89	1.77	1.02	3.3
8-024-13	12,000	5.3	1.34	0.79	1.57	6.73	2.52	2.09	1.19	6.6
8-024-16	18,100	8.0	1.46	0.98	1.93	8.03	2.95	2.44	1.42	12.1
8-024-20	28,300	12.5	1.69	1.50	2.36	8.62	3.54	3.54	1.91	19.0
8-024-22	34,200	15.0	2.01	1.77	2.48	9.88	4.53	3.14	2.12	26.0
8-024-26	47,700	21.2	2.56	1.97	2.72	10.67	5.94	3.90	2.20	37.2

** d min. = the smallest shank dimension after machining.

Note: After machining the shank, proof loading must be carried out.

★ Design factor 4:1

Clevis Swivel Self Locking Hook. Code " KP "

with Ball Bearing, which performs full swivel under load

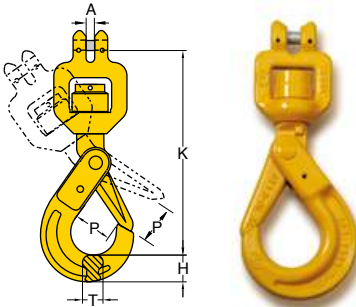

Item No.	Working Load Limit		For Grade 80 Chain inch	Dimensions (inch)					N.W. lbs
	lbs*	tonnes*		A	H	K	P	T	
8-022-06	2,500	1.12	7/32	0.24	0.75	6.14	1.14	0.59	1.8
8-022-07	4,500	2.0	1/4-5/16	0.35	0.94	7.40	1.34	0.79	2.9
8-022-10	7,100	3.15	3/8	0.43	1.19	8.46	1.77	1.02	4.9
8-022-13	12,000	5.3	1/2	0.55	1.57	10.83	2.13	1.19	9.9
8-022-16	18,100	8.0	5/8	0.71	1.93	12.72	2.44	1.42	17.4
8-022-20	28,300	12.5	3/4	0.83	2.36	16.45	3.54	1.91	27.6

★ Design factor 4:1 proof tested and certified
Tested acc. to EN 1677

Eye Swivel Hook. Code " YSW "

with Brass Bushing

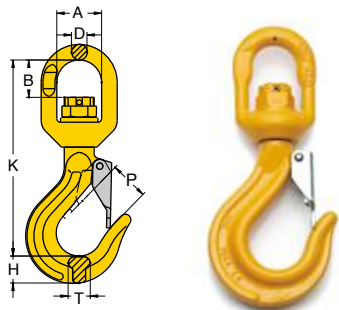

Item No.	Working Load Limit		For Grade 80 Chain inch	Dimensions (inch)							N.W. lbs
	lbs*	tonnes*		A	B	D	H	K	P	T	
8-049-06	2,500	1.12	7/32	1.26	0.88	0.44	0.74	5.35	0.94	0.64	1.3
8-049-07	4,500	2.0	1/4-5/16	1.42	1.06	0.51	0.87	6.10	1.02	0.71	1.9
8-049-10	7,100	3.15	3/8	1.63	1.46	0.62	1.14	7.44	1.42	0.91	3.5
8-049-13	12,000	5.3	1/2	1.81	1.57	0.83	1.38	9.17	1.65	1.10	7.1
8-049-16	18,100	8.0	5/8	2.36	1.97	0.91	1.73	11.02	1.97	1.38	11.7
8-049-20	28,300	12.5	3/4	2.91	3.23	1.02	2.56	14.00	2.20	1.91	20.3

★ Design factor 4:1 proof tested and certified
Tested acc. to EN 1677

⚠ **WARNING INFORMATION:** This hook is a positioning device and is not intended to rotate under load. For swivel hooks designed to rotate under load, see p.130 8-049N.



Eye Swivel Hook. Code "YSWN "

with Ball Bearing, which performs full swivel under load

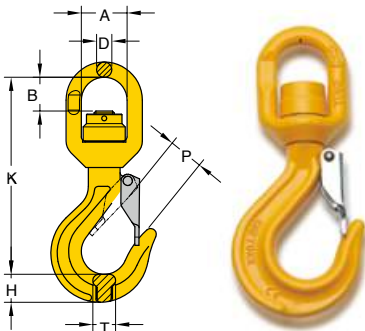

Item No.	Working Load Limit		For Grade 80 Chain inch	Dimensions (inch)							N.W. lbs
	lbs*	tonnes*		A	B	D	H	K	P	T	
8-049N-06	2,500	1.12	7/32	1.26	0.88	0.44	0.74	5.35	0.94	0.64	1.3
8-049N-07	4,500	2.0	1/4-5/16	1.42	1.06	0.51	0.87	6.10	1.02	0.71	2.0
8-049N-10	7,100	3.15	3/8	1.63	1.46	0.62	1.14	7.44	1.42	0.91	3.5
8-049N-13	12,000	5.3	1/2	1.81	1.57	0.83	1.38	9.17	1.65	1.10	7.5
8-049N-16	18,100	8.0	5/8	2.36	1.97	0.91	1.73	11.02	1.97	1.38	11.7
8-049N-20	28,300	12.5	3/4	2.91	3.23	1.02	2.56	14.00	2.20	1.91	20.5

★ Design factor 4:1 proof tested and certified
Tested acc. to EN 1677

Eye Sling Hook. Code "YP"

with Latch

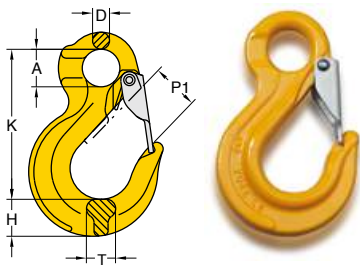

ABS

Type Approval

Item No.	Working Load Limit		For Grade 80 Chain inch	Dimensions (inch)						N.W. lbs
	lbs*	tonnes*		A	D	H	K	P1	T	
8-044/S-06	2,500	1.12	7/32	0.79	0.35	0.79	3.15	0.94	0.63	0.7
8-044/S-07	4,500	2.0	1/4-5/16	0.98	0.43	0.91	3.86	1.18	0.75	1.1
8-044/S-10	7,100	3.15	3/8	1.26	0.59	1.22	4.76	1.42	0.91	2.0
8-044/S-13	12,000	5.3	1/2	1.57	0.71	1.50	5.98	1.69	1.10	4.2
8-044/S-16	18,100	8.0	5/8	1.97	0.87	1.85	7.20	1.85	1.29	7.1
8-044/S-20	28,300	12.5	3/4	2.36	1.06	1.89	8.54	1.77	1.69	12.6
8-044/S-22	34,200	15.0	7/8	2.01	1.26	2.44	9.45	2.75	1.97	20.1
8-044/S-26	47,700	21.2	1	2.60	1.34	3.15	10.63	3.15	2.36	30.0
8-044/S-32	72,300	31.5	1-1/4	3.50	1.57	3.39	13.86	4.49	2.56	41.2

★ Design factor 4:1 proof tested and certified
Tested acc. to EN 1677

Eye Sling Hook. Code "EL"

with Latch

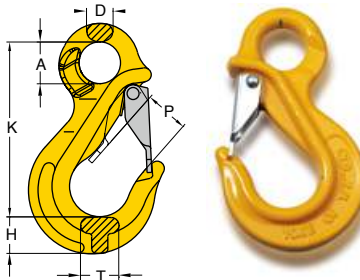

Item No.	Working Load Limit		For Grade 80 Chain inch	Dimensions (inch)						N.W. lbs
	lbs*	tonnes*		A	D	H	K	P	T	
8-039-06	2,500	1.12	7/32	0.78	0.35	0.75	3.15	0.90	0.63	0.7
8-039-07	4,500	2.0	1/4-5/16	1.02	0.62	0.90	4.29	1.10	0.94	1.5
8-039-10	7,100	3.15	3/8	1.33	0.76	1.18	5.39	1.29	1.02	2.6
8-039-13	12,000	5.3	1/2	1.65	0.90	1.45	6.81	1.57	1.37	5.5
8-039-16	18,100	8.0	5/8	2.04	1.10	1.81	7.28	1.73	1.41	8.2

★ Design factor 4:1 proof tested and certified Tested acc. to EN 1677



Eye Foundry Hook. Code "YN"

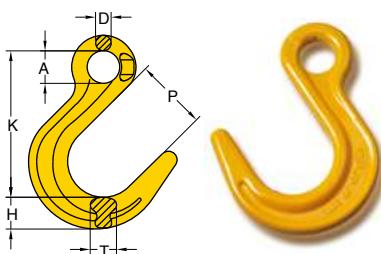

Item No.	Working Load Limit		For Grade 80 Chain inch	Dimensions (inch)						N.W. lbs
	lbs*	tonnes*		A	D	H	K	P	T	
8-047-07	4,500	2.0	1/4-5/16	0.94	0.47	1.18	4.84	2.44	0.79	1.5
8-047-10	7,100	3.15	3/8	1.26	0.59	1.34	5.91	2.87	0.94	2.9
8-047-13	12,000	5.3	1/2	1.56	0.75	1.65	7.09	3.50	1.34	5.3
8-047-16	18,100	8.0	5/8	1.96	0.98	1.97	8.46	3.94	1.63	8.8
8-047-20	28,300	12.5	3/4	2.36	1.10	2.25	9.76	4.41	1.81	20.7

★ Design factor 4:1 proof tested and certified
Tested acc. to EN 1677

Clevis Sling Hook. Code "YM"

with Latch

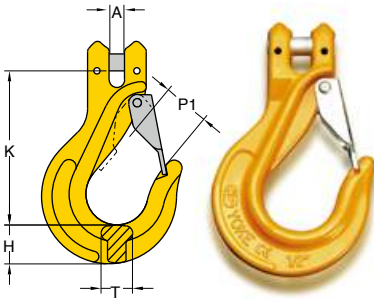

Item No.	Working Load Limit		For Grade 80 Chain inch	Dimensions (inch)					N.W. lbs
	lbs*	tonnes*		A	H	K	P1	T	
8-043/S-06	2,500	1.12	7/32	0.24	0.70	3.07	0.87	0.59	0.7
8-043/S-07	4,500	2.0	1/4-5/16	0.35	0.91	3.74	1.18	0.75	1.3
8-043/S-10	7,100	3.15	3/8	0.43	1.14	4.72	1.42	0.91	2.6
8-043/S-13	12,000	5.3	1/2	0.55	1.50	5.79	1.73	1.10	5.1
8-043/S-16	18,100	8.0	5/8	0.71	1.65	6.65	1.81	1.54	8.4
8-043/S-20	28,300	12.5	3/4	0.83	2.01	7.87	2.20	1.85	14.8

★ Design factor 4:1 proof tested and certified
Tested acc. to EN 1677

Clevis Shackle. Code "YR"

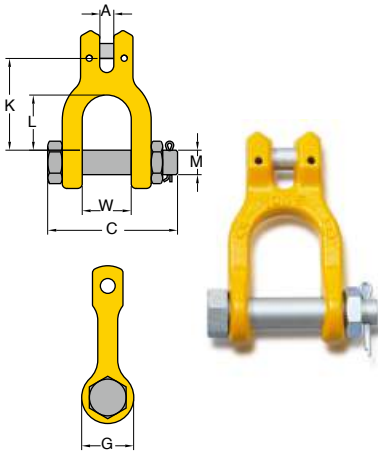

Item No.	Working Load Limit		For Grade 80 Chain inch	Dimensions (inch)						N.W. lbs	
	lbs*	tonnes*		A	C	G	K	L	M		W
8-066-07	4,500	2.0	1/4-5/16	0.35	3.11	1.34	2.32	1.38	0.63	1.30	0.9
8-066-10	7,100	3.15	3/8	0.43	3.66	1.57	3.07	1.89	0.79	1.46	1.8
8-066-13	12,000	5.3	1/2	0.55	4.65	1.73	3.86	2.52	0.87	1.93	3.1
8-066-16	18,100	8.0	5/8	0.71	5.55	2.13	4.41	2.72	1.10	2.36	5.5

★ Design factor 4:1 proof tested and certified
Tested acc. to EN 1677

Clevis C Hook. Code "FE"

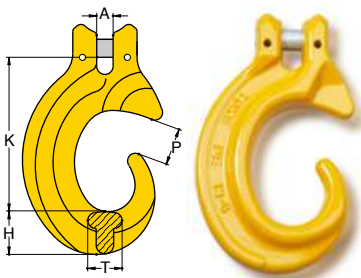

Item No.	Working Load Limit		For Grade 80 Chain inch	Dimensions (inch)					N.W. lbs
	lbs*	tonnes*		A	H	K	P	T	
8-097-07	4,500	2.0	1/4-5/16	0.35	0.87	3.15	0.75	0.71	1.1
8-097-10	7,100	3.15	3/8	0.43	1.02	4.13	1.02	0.94	2.0
8-097-13	12,000	5.3	1/2	0.55	1.34	5.43	1.34	1.26	4.6
8-097-16	18,100	8.0	5/8	0.71	1.77	6.69	1.50	1.46	7.9

★ Design factor 4:1 proof tested and certified
Tested acc. to EN 1677

Clevis Forest Hook. Code "YT"

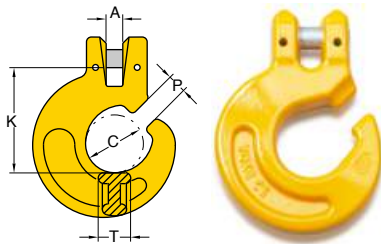

Item No.	Working Load Limit		For Grade 80 Chain	Dimensions (inch)					N.W.
	lbs*	tonnes*	inch	A	C	K	P	T	lbs
8-075-06	2,500	1.12	7/32	0.31	1.02	1.85	0.31	0.67	0.7
8-075-07	4,500	2.0	1/4-5/16	0.35	1.26	2.28	0.39	0.71	1.1
8-075-10	7,100	3.15	3/8	0.51	1.77	3.23	0.47	0.83	2.0
8-075-13	12,000	5.3	1/2	0.55	1.85	3.93	0.62	1.06	3.7

★ Design factor 4:1 proof tested and certified
Tested acc. to EN 1677

Clevis Choker. Code "YF"

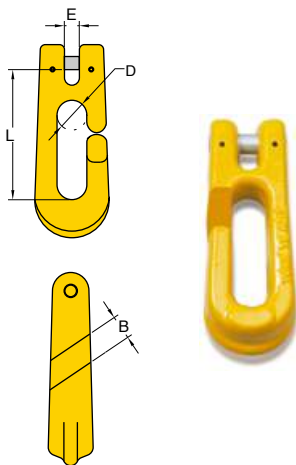

Item No.	Working Load Limit		For Grade 80 Chain	Dimensions (inch)				N.W.
	lbs*	tonnes*	inch	B	D	E	L	lbs
8-091-06	3,500	1.5	7/32-1/4	0.57	0.63	0.35	3.09	1.1
8-091-08	4,500	2.0	5/16	0.61	0.67	0.37	3.23	1.3

★ Design factor 4:1 proof tested and certified
Tested acc. to EN 1677

**Item No.8-Tag-03
Sling Tag, Steel.**

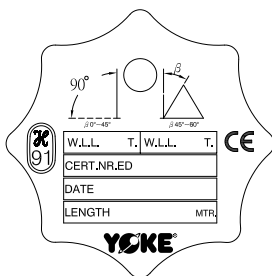

**Item No.8-Tag-04
Sling Tag, Stainless**

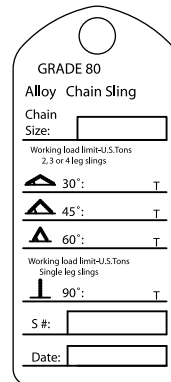

Eye Grab Hook. Code "YH"

Not for use with Omega Link Item. 8-018
No reduction of working load limit, thanks to supporting wings which prevent chain link deformation.

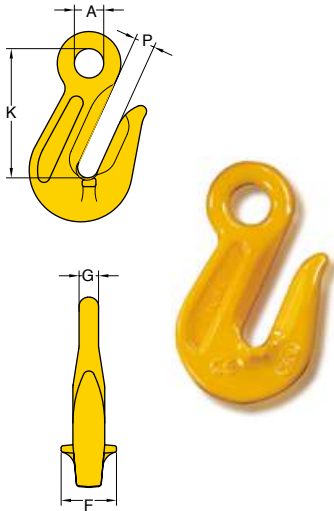

Item No.	Working Load Limit		For Grade 80 Chain inch	Dimensions (inch)					N.W. lbs
	lbs*	tonnes*		A	F	G	K	P	
8-041-06	2,500	1.12	7/32	0.51	0.98	0.31	2.01	0.31	0.4
8-041-07	4,500	2.0	1/4-5/16	0.59	1.18	0.35	2.36	0.39	0.7
8-041-10	7,100	3.15	3/8	0.79	1.61	0.51	3.22	0.51	1.3
8-041-13	12,000	5.3	1/2	0.98	2.05	0.59	4.02	0.63	3.1
8-041-16	18,100	8.0	5/8	1.18	2.24	0.79	5.16	0.79	4.9
8-041-20	28,300	12.5	3/4	1.49	2.87	0.91	5.75	0.91	8.4
8-041-22	34,200	15.0	7/8	1.50	2.76	1.02	6.42	1.02	10.1
8-041-26	47,700	21.2	1	1.81	3.94	1.26	8.07	1.14	22.7
8-041-32	72,300	31.5	1-1/4	2.28	5.00	1.61	10.51	1.53	44.1

★ Design factor 4:1 proof tested and certified.
Tested acc. to EN 1677

Clevis Grab Hook. Code "YK"

Not for use with Omega Link Item. 8-018
No reduction of working load limit, thanks to supporting wings which prevent chain link deformation.

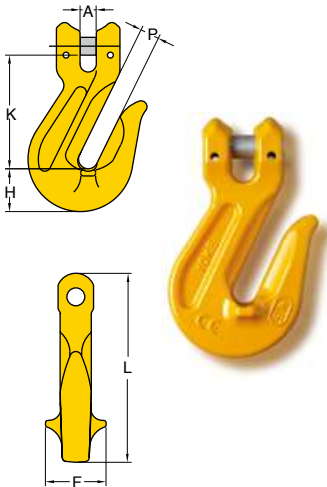

Item No.	Working Load Limit		For Grade 80 Chain inch	Dimensions (inch)						N.W. lbs
	lbs*	tonnes*		A	F	H	K	L	P	
8-042-06	2,500	1.12	7/32	0.28	0.98	0.63	1.61	3.11	0.31	0.4
8-042-07	4,500	2.0	1/4-5/16	0.35	1.18	0.98	2.17	3.66	0.39	0.7
8-042-10	7,100	3.15	3/8	0.47	1.61	1.38	3.03	5.04	0.51	1.8
8-042-13	12,000	5.3	1/2	0.59	2.09	1.65	3.82	5.98	0.63	3.5
8-042-16	18,100	8.0	5/8	0.67	2.22	1.77	4.47	7.66	0.79	6.2
8-042-20	28,300	12.5	3/4	0.91	3.86	2.13	4.88	8.54	0.91	11.0

★ Design factor 4:1 proof tested and certified.
Tested acc. to EN 1677

Clevis Clutch - Locking Type. Code "KCK"

Item No.	Working Load Limit		For Grade 80 Chain inch	Dimensions (inch)						N.W. lbs
	lbs*	tonnes*		A	B	C	D	E	F	
8-061-06	2,500	1.12	7/32	0.28	0.28	0.39	0.28	0.71	1.97	0.7
8-061-07	4,500	2.0	1/4-5/16	0.37	0.37	0.40	0.39	0.94	2.22	1.1
8-061-10	7,100	3.15	3/8	0.47	0.45	0.45	0.47	1.10	2.59	2.0
8-061-13	12,000	5.3	1/2	0.59	0.59	0.63	0.63	1.54	3.46	4.6
8-061-16	18,100	8.0	5/8	0.71	0.83	0.72	0.75	1.90	4.06	8.2
8-061-20	28,300	12.5	3/4	0.91	0.91	0.91	0.83	2.17	5.18	12.6

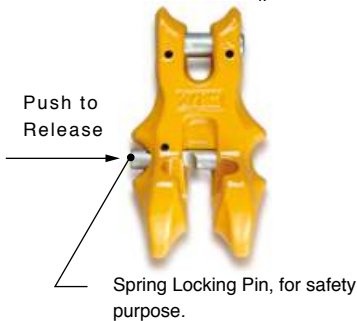
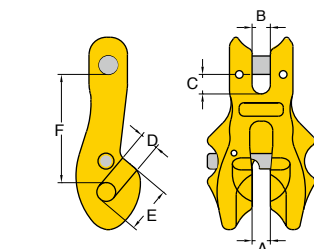

★ Design factor 4:1 proof tested and certified.
Tested acc. to EN 1677



Clevis Clutch. Code "KC"

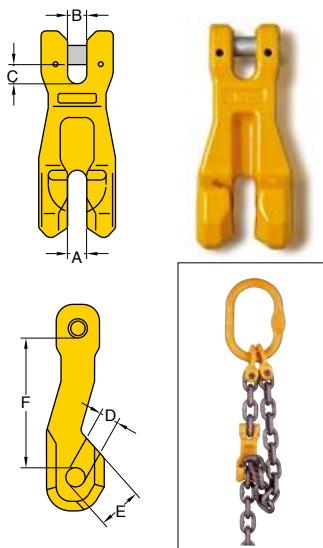

Item No.	Working Load Limit		For Grade 80 Chain inch	Dimensions (inch)					N.W. lbs
	lbs*	tonnes*		A,B	C	D	E	F	
8-060-06	2,500	1.12	7/32	0.26	0.31	0.28	0.43	1.77	0.4
8-060-07	4,500	2.0	1/4-5/16	0.34	0.39	0.35	0.63	2.44	1.1
8-060-10	7,100	3.15	3/8	0.49	0.55	0.47	0.98	3.43	2.2
8-060-13	12,000	5.3	1/2	0.65	0.67	0.59	1.26	4.53	4.4
8-060-16	18,100	8.0	5/8	0.81	0.75	0.75	1.54	5.63	7.1
8-060-20	28,300	12.5	3/4	0.85	0.91	0.87	1.81	5.98	10.8

★ Design factor 4:1 proof tested and certified.
Tested acc. to EN 1677

Eye Shortening Hook. Code "KD"

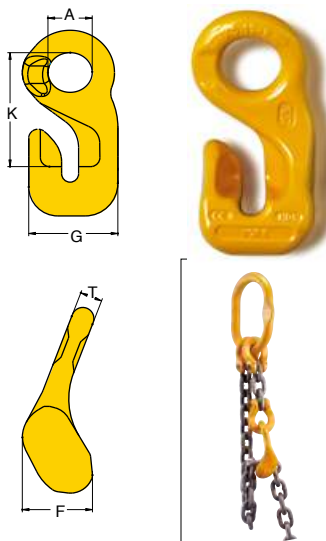

Item No.	Working Load Limit		For Grade 80 Chain inch	Dimensions (inch)					N.W. lbs
	lbs*	tonnes*		A	F	G	K	T	
8-062-06	2,500	1.12	7/32	0.79	1.38	1.50	2.13	0.39	0.4
8-062-07	4,500	2.0	1/4-5/16	0.98	1.73	1.93	2.64	0.47	1.1
8-062-10	7,100	3.15	3/8	1.26	2.24	2.36	2.95	0.55	2.0
8-062-13	12,000	5.3	1/2	1.57	2.87	3.15	4.17	0.75	4.2
8-062-16	18,100	8.0	5/8	1.97	3.46	3.82	5.16	0.87	7.7
8-062-20	28,300	12.5	3/4	2.36	4.21	4.49	6.30	1.06	12.8

★ Design factor 4:1 proof tested and certified.
Tested acc. to EN 1677

Clevis Traveling Clutch. Code "KR"

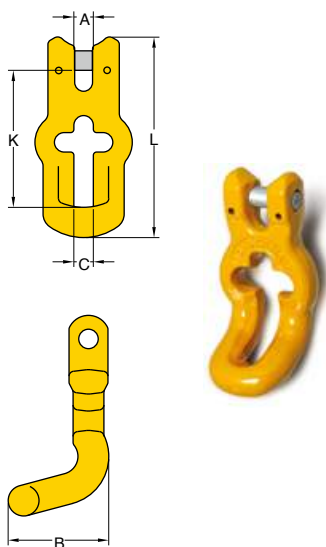

Item No.	Working Load Limit		For Grade 80 Chain inch	Dimensions (inch)					N.W. lbs
	lbs*	tonnes*		A	B	C	K	L	
8-064-06	2,500	1.12	7/32	0.28	1.22	0.31	2.52	3.39	0.4
8-064-07	4,500	2.0	1/4-5/16	0.39	1.73	0.39	2.87	4.09	0.9
8-064-10	7,100	3.15	3/8	0.43	2.40	0.51	3.23	4.76	1.5

★ Design factor 4:1 proof tested and certified.
Tested acc. to EN 1677

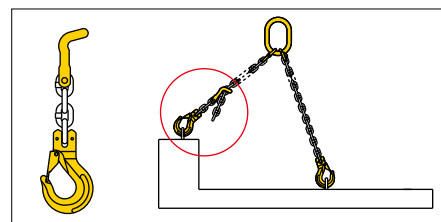

Clutch Sling Hook - Locking Clutch. Code "EF"

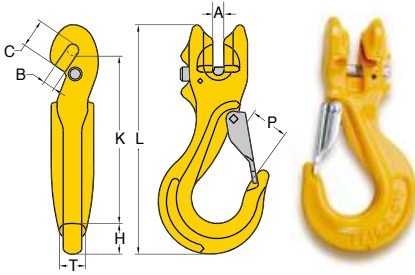

Patent

Item No.	Working Load Limit		For Grade 80 Chain	Dimensions (inch)								N.W.
	lbs*	tonnes*	inch	A	B	C	H	K	L	P	T	lbs
8-077-06	2,500	1.12	7/32	0.28	0.28	0.67	0.71	4.00	5.33	0.85	0.61	1.1
8-077-07	4,500	2.0	1/4-5/16	0.38	0.40	0.94	0.93	4.85	6.75	1.04	0.72	1.8
8-077-10	7,100	3.15	3/8	0.47	0.47	1.10	1.34	5.85	8.40	1.32	0.93	3.8
8-077-13	12,000	5.3	1/2	0.60	0.63	1.14	1.46	7.05	10.06	1.71	1.18	7.5
8-077-16	18,100	8.0	5/8	0.80	0.75	1.90	1.66	8.36	12.00	1.80	1.54	12.4

★ Design factor 4:1 proof tested and certified.

Tested acc. to EN 1677



Double End Claw, with fixed pin. Code "KT"

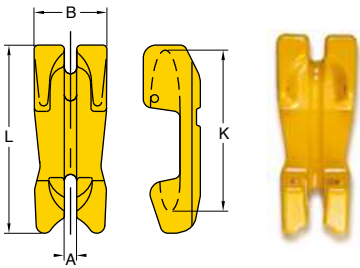

ItemNo.	Working Load Limit		For Grade 80 Chain	Dimensions (inch)				N.W.
	lbs*	tonnes*	inch	A	B	K	L	lbs
8-065-06	2,500	1.12	7/32	0.28	1.46	2.87	3.70	0.7
8-065-07	4,500	2.0	1/4-5/16	0.39	1.89	3.90	4.88	1.3
8-065-10	7,100	3.15	3/8	0.51	2.36	4.88	6.10	2.7
8-065-13	12,000	5.3	1/2	0.59	2.95	5.91	7.68	5.7
8-065-16	18,100	8.0	5/8	0.75	3.70	7.60	9.72	11.5

★ Design factor 4:1 proof tested and certified.

Tested acc. to EN 1677

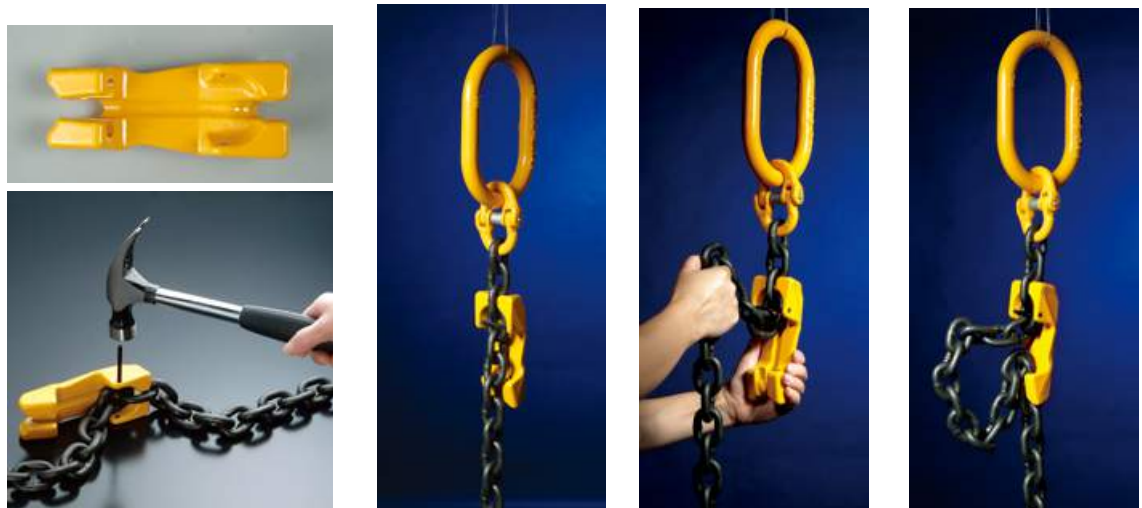

Shortening Clutch. Code "EX"

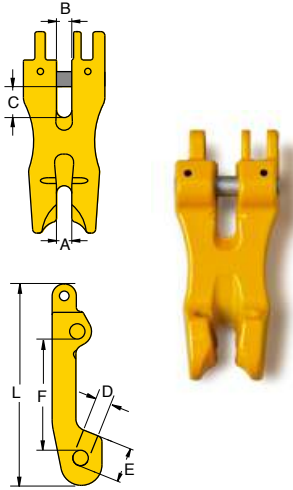

Item No.	Working Load Limit		For Grade 80 Chain	Dimensions (inch)							N.W.
	lbs*	tonnes*	inch	A	B	C	D	E	F	L	lbs
8-072-07	4,500	2.0	1/4-5/16	0.47	0.79	0.39	0.40	0.87	2.77	5.01	1.3
8-072-10	7,100	3.15	3/8	0.51	1.02	0.47	0.47	1.10	3.43	6.18	2.4
8-072-13	12,000	5.3	1/2	0.59	1.30	0.63	0.63	1.46	4.58	8.66	5.3
8-072-16	18,100	8.0	5/8	0.83	1.54	0.75	0.75	1.77	4.91	10.00	10.1

★ Design factor 4:1 proof tested and certified.
Tested acc. to EN 1677

Shortening Clutch

with Half Link

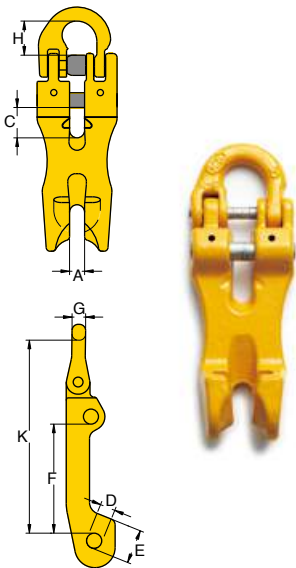

Item No.	Working Load Limit		For Grade 80 Chain	Dimensions (inch)								N.W.
	lbs*	tonnes*	inch	A	C	D	E	F	G	H	K	lbs
8-078-07	4,500	2.0	1/4-5/16	0.47	0.79	0.39	0.91	2.76	0.89	0.35	5.04	1.5
8-078-10	7,100	3.15	3/8	0.51	1.02	0.47	1.14	3.43	1.06	0.50	6.06	2.9
8-078-13	12,000	5.3	1/2	0.59	1.30	0.63	1.46	4.53	1.38	0.62	7.99	6.2
8-078-16	18,100	8.0	5/8	0.83	1.54	0.75	1.81	5.63	1.51	0.75	9.76	11.7

★ Design factor 4:1 proof tested and certified.
Tested acc. to EN 1677

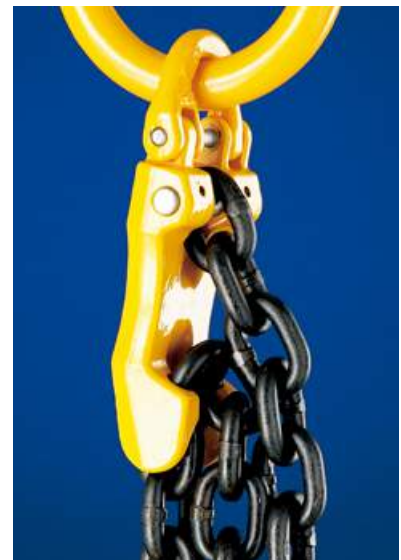

Eye Container Hook. Code"KA"

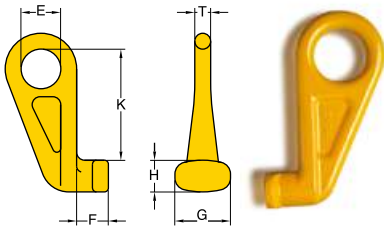

Item No.	DSC.	Working Load Limit		Dimensions (inch)						N.W.
		lbs*	tonnes*	E	F	G	H	K	T	lbs
8-067-STR	Straight	28,000	12.5	2.76	1.81	2.95	1.89	7.56	0.98	8.6
8-067-45LT	Left 45°	28,000	12.5	2.76	1.81	2.95	1.89	7.56	0.98	8.6
8-067-45RH	Right 45°	28,000	12.5	2.76	1.81	2.95	1.89	7.56	0.98	8.6

8-067-45LT

8-067-45RH

8-067-STR



★ Design factor 4:1 proof tested and certified.



Clevis Container Hook. Code"KB"

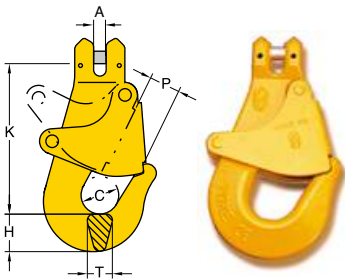

Item No.	Working Load Limit		For Grade 80 Chain	Dimensions (inch)						N.W.
	lbs*	tonnes*	inch	A	C	H	K	P	T	lbs
8-068-13	12,000	5.3	1/2	0.59	2.05	1.73	1.10	1.73	7.48	7.8

★ Design factor 4:1 proof tested and certified.
Tested acc. to EN 1677

Clevis Container Link. Code"KU"

with Spring Gate

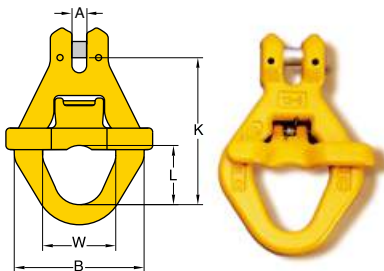

Item No.	Working Load Limit		For Grade 80 Chain	Dimensions (inch)					N.W.
	lbs*	tonnes*	inch	A	B	K	L	W	lbs
8-069-13	12,000	5.3	1/2	0.55	5.55	2.24	2.56	4.92	4.0

★ Design factor 4:1 proof tested and certified.
Tested acc. to EN 1677

Container Hook. Code "KL"

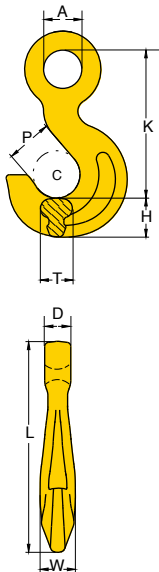

Item No.	Working Load Limit		For Grade 80 Chain	Dimensions (inch)								N.W.
	lbs*	tonnes*	inch	A	D	H	K	L	P	T	W	lbs
8-073-16	18,100	8.0	5/8	1.93	1.26	1.97	7.44	10.31	2.28	1.61	1.73	8.2

★ Design factor 4:1 proof tested and certified.
Tested acc. to EN 1677

Shackle Eye Swivel Hook, with brass bushing. Code "YSWX"

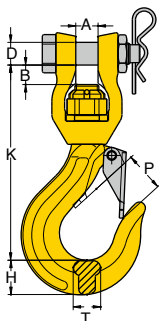

Item No.	Working Load Limit		For Grade 80 Chain	Dimensions (inch)								N.W.
	lbs*	tonnes*	inch	A	B	D	H	K	P	T	lbs	
8-048-16	18,100	8.0	5/8	1.10	1.10	1.10	1.77	8.86	2.13	1.38	13.0	

★ Design factor 4:1 proof tested and certified.
Tested acc. to EN 1677

⚠ **WARNING INFORMATION:** This hook is a positioning device and is not intended to rotate under load.

Sliding Choke Hook. Code "KF"

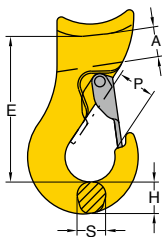

Item No.	Working Load Limit		For Wire Rope	Dimensions (inch)					N.W.
	lbs*	tonnes*	inch	A	E	H	P	S	lbs
8-074-09/13	3,300	1.5	3/8	0.63	3.43	0.94	0.71	0.71	1.3
8-074-14/16	4,850	2.2	9/16	0.83	3.86	1.14	0.79	0.87	2.0

★ Design factor 5 : 1

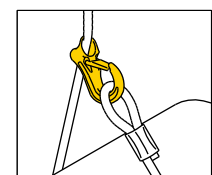

Twist Eye Choke Hook. Code "KE"

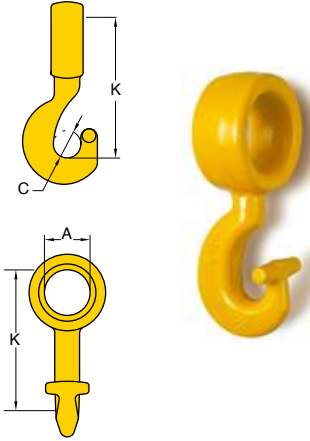

Item No.	Working Load Limit		For Grade 80 Chain	Dimensions (inch)			N.W.
	lbs*	tonnes*	inch	A	C	K	lbs
8-063-07	4,500	2.0	1/4-5/16	1.28	0.75	3.74	0.9
8-063-10	7,100	3.15	3/8	1.61	0.83	4.57	1.8
8-063-13	12,000	5.3	1/2	1.97	1.06	5.91	4.4
8-063-16	18,100	8.0	5/8	2.64	1.26	7.28	6.8

★ Design factor 4:1 proof tested and certified.
Tested acc. to EN 1677

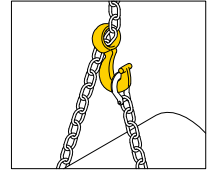

Rapid Double End Choker. Code "KS"

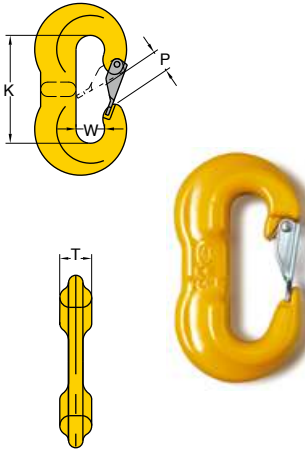

Item No.	Working Load Limit		For Wire Rope	Dimensions (inch)				N.W.
	lbs*	tonnes*	inch	K	P	T	W	lbs
8-076-0.5	1,100	0.5	5/16	2.83	0.75	0.47	0.71	0.9
8-076-01	2,200	1.0	1/2	2.83	0.75	0.79	0.71	1.1
8-076-02	4,400	2.0	5/8	3.50	0.75	1.10	1.02	2.4
8-076-04	8,800	4.0	3/4	4.29	0.98	1.26	1.34	4.2

★ Design factor 5:1 proof tested and certified.

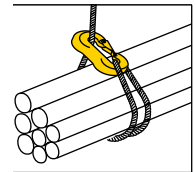

Barrel Hook. Code "KK"

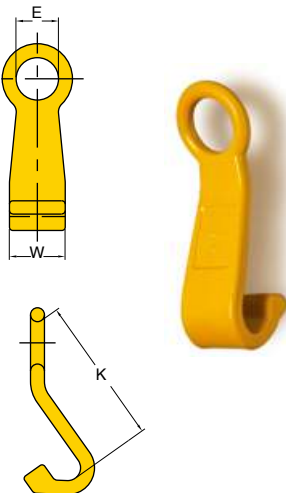

Item No.	Working Load Limit		For Grade 80 Chain	Dimensions (inch)			N.W.
	lbs*	tonnes*	inch	E	K	W	lbs
8-071-07	3,500	1.6	1/4	1.50	5.24	1.97	2.0

★ Design factor 4:1 proof tested and certified.

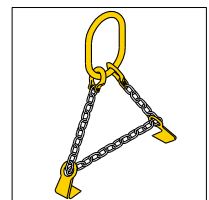

Shank Sling Hook. Code "FH"

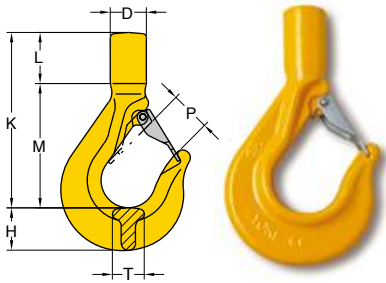

Item No.	Working Load Limit		For Grade 80 Chain	Dimensions (inch)								N.W.
	lbs*	tonnes*	inch	D	d min***	H	K	L	M	P	T	lbs
8-045-10	7,100	3.15	3/8	1.38	M20	1.69	8.31	1.81	5.51	1.65	1.26	3.5

**d min.: the smallest shank dimension after machining.

Note: After machining the shank proof loading must be carried out.

★ Design factor 4:1

Tractor Hook. Code "FG"

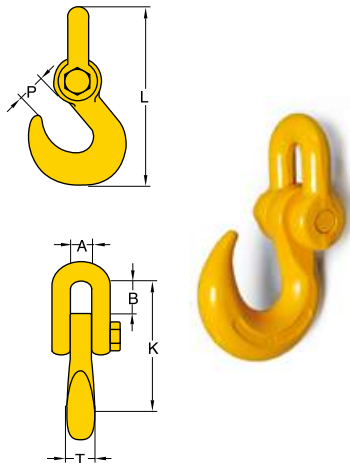

Item No.	Working Load Limit		Dimensions (inch)							N.W.
	lbs*	tonnes*	A	B	K	L	P	T	lbs	
8-092-38	18,700	8.5	1.26	1.69	7.2	10.43	1.18	1.65	12.4	
8-092-45	24,200	11	1.26	1.69	8.4	11.81	1.30	1.81	15.4	

★ Design factor 4:1 proof tested and certified.

Super Lock Hook

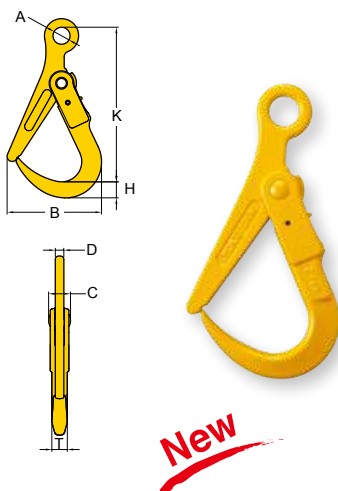

Item No.	Working Load Limit		Dimensions (inch)								N.W.
	lbs*	tonnes*	A	B	C	D	H	K	P	T	lbs
8-019-02	4,400	2	1.26	6.97	1.61	0.63	1.18	11.42	4.25	1.14	7.7
8-019-03	6,600	3	1.26	6.97	1.61	0.63	1.18	11.42	4.25	1.14	7.7

★ Design factor 5:1 proof tested and certified.

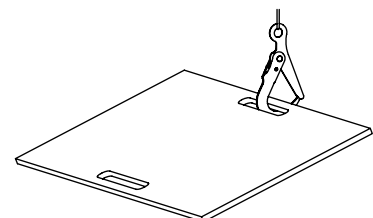

Eye Swivels

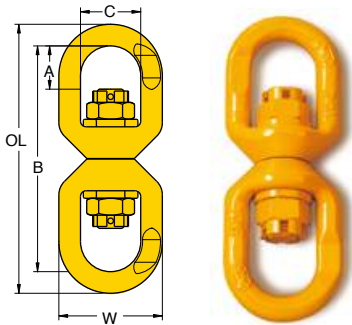

Item No.	Working Load Limit		For Grade 80 Chain	Dimensions (inch)						N.W.
	lbs*	tonnes*	inch	A	B	C	OL	W	lbs	
8-080-06	2,500	1.12	7/32	0.86	4.72	1.26	5.63	2.17	1.3	
8-080-07	4,500	2.0	1/4-5/16	1.14	5.51	1.42	6.50	2.36	2.2	
8-080-10	7,100	3.15	3/8	1.34	6.54	1.63	7.80	2.87	3.1	
8-080-13	12,000	5.3	1/2	1.70	8.35	1.81	10.00	3.46	6.6	
8-080-16	18,100	8.0	5/8	1.97	9.84	2.35	11.65	4.21	10.1	
8-080-20	28,300	12.5	3/4	3.23	13.26	2.91	15.20	5.00	16.8	
8-080-22	34,200	15.0	7/8	3.74	16.22	3.82	18.52	6.61	40.1	
8-080-26	47,700	21.2	1	4.53	20.43	4.13	23.70	8.31	80.3	

★ Design factor 4:1 proof tested and certified. Tested acc. to EN 1677

⚠ **WARNING INFORMATION:** This hook is a positioning device and is not intended to rotate under load.

Quick Connector. Code "EM"

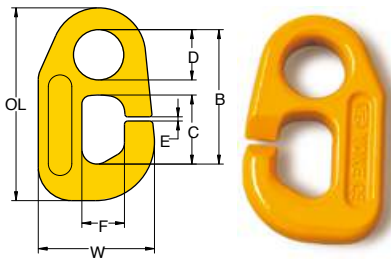

Item No.	Working Load Limit		Dimensions (inch)							N.W.
	lbs*	tonnes*	B	C	D	E	F	OL	W	lbs
8-089-10	6,600	3.0	3.15	1.61	1.18	0.1	0.98	4.53	2.76	1.5
8-089-13	11,000	5.0	3.74	1.88	1.42	0.1	1.18	5.35	3.15	2.6
8-089-16	17,600	8.0	4.25	1.97	1.65	0.1	1.41	6.10	3.78	4.4

★ Design factor 4:1 proof tested and certified.

Quick Hook. Code "FA"

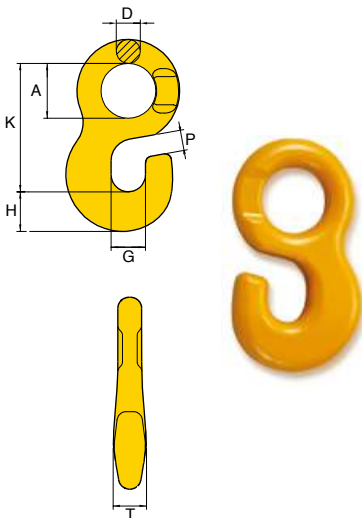

Item No.	Working Load Limit		For Grade 80 Chain	Dimensions (inch)							N.W.
	lbs*	tonnes*	inch	A	D	G	H	K	P	T	lbs
8-093-10	7,100	3.15	3/8	1.26	0.59	0.79	0.91	3.00	0.47	0.83	0.9
8-093-13	12,000	5.3	1/2	1.50	0.71	1.10	1.10	3.66	0.55	0.98	2.0
8-093-16	18,100	8.0	5/8	1.97	0.87	1.26	1.34	4.65	0.67	1.26	3.8
8-093-19	25,500	11.5	3/4	2.32	1.02	1.50	1.73	5.67	0.83	1.42	7.3

★ Design factor 4:1 proof tested and certified.



How to use YOKE Web Sling Connector?

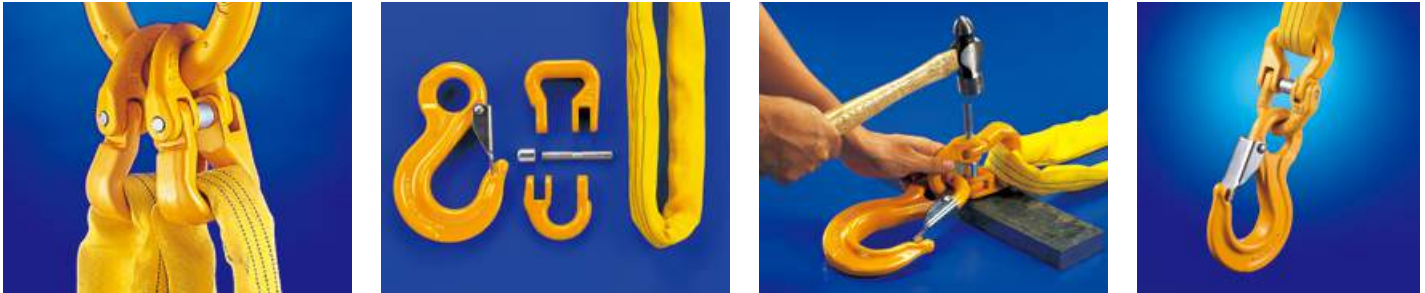

Web Sling Connector

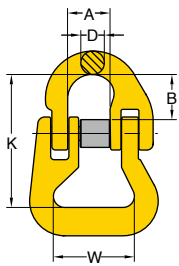

Item No.	Working Load Limit		For Grade 80 Chain	Dimensions (inch)					N.W.
	lbs*	tonnes*	inch	A	B	D	K	W	lbs
8-016-06	2,500	1.12	7/32	0.59	0.67	0.28	2.16	1.54	0.4
8-016-07	4,500	2.0	1/4-5/16	0.71	0.89	0.35	2.44	1.57	0.7
8-016-10	7,100	3.15	3/8	0.99	1.06	0.50	3.07	1.85	1.3
8-016-13	12,000	5.3	1/2	1.19	1.38	0.62	3.74	2.09	2.4
8-016-16	18,100	8.0	5/8	1.42	1.51	0.75	4.53	2.64	4.4
8-016-20	28,300	12.5	3/4	1.65	1.81	0.87	5.20	3.15	7.1
8-016-22	34,200	15.0	7/8	1.93	2.32	0.94	7.36	4.92	16.3
8-016-26	47,700	21.2	1	2.17	2.44	1.19	8.23	5.91	25.3
8-016-32	72,300	31.5	1-1/4	2.72	3.11	1.42	10.98	7.48	40.6

★ Design factor 4:1 proof tested and certified.
Tested acc. to EN 1677

Eye Self Locking Webbing Hook. Code "FT"

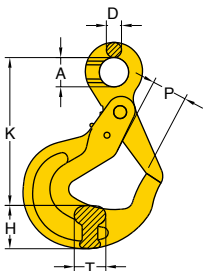

Item No.	Working Load Limit		For Grade 80 Chain	Dimensions (inch)						N.W.
	lbs*	tonnes*	inch	A	D	H	K	P	T	lbs
8-029-10	7,100	3.15	3/8	1.26	0.51	165	6.69	1.50	1.26	5.5

★ Design factor 4:1 proof tested and certified.
Tested acc. to EN 1677

Flat Webbing Choker. Code "FN"

Patent No. : Germany 40144213.8
Taiwan 90301916

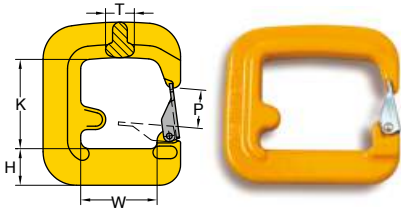

Item No.	Working Load Limit		Dimensions (inch)					N.W.	
	lbs*	tonnes*	H	K	P	T	W	lbs	
8-030-01	2,200	1	1.02	3.11	1.02	0.83	1.73	1.8	
8-030-02	4,400	2	1.38	3.43	1.34	0.98	2.80	3.5	
8-030-03	6,600	3	1.50	3.78	1.46	1.14	4.02	5.3	
8-030-05	11,000	5	1.97	6.10	1.77	1.57	6.73	17.2	

★ Design factor 4:1 proof tested and certified.

Flat Webbing Choker. Code "FM"

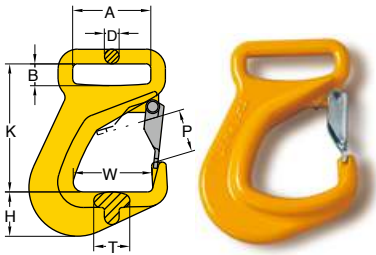

Item No.	Working Load Limit		Dimensions (inch)								N.W.	
	lbs*	tonnes*	A	B	D	H	K	P	T	W	lbs	
8-031-02	4,400	2.0	3.19	0.94	0.55	1.73	5.51	1.73	1.57	3.15	4.6	

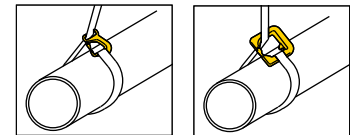

★ Design factor 4:1 proof tested and certified.

Bolt Anchor. Code "DC"

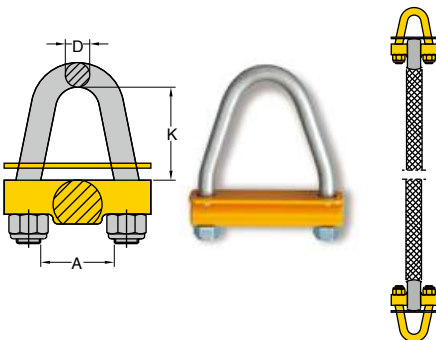

Item No.	Working Load Limit		Dimensions (inch)			N.W.
	lbs*	tonnes*	A	D	K	lbs
8-036-05	5,500	2.5	2.72	0.55	2.32	1.5
8-036-06	7,050	3.2	3.11	0.55	2.64	1.8
8-036-07	9,260	4.2	3.78	0.63	3.50	2.9
8-036-10	9,260	4.2	4.76	0.63	4.29	3.3
8-036-12	14,100	6.4	5.98	0.79	5.31	5.3
8-036-15	14,100	6.4	7.09	0.79	6.77	7.7

★ Design factor 5:1

Round Sling Self Locking Hook

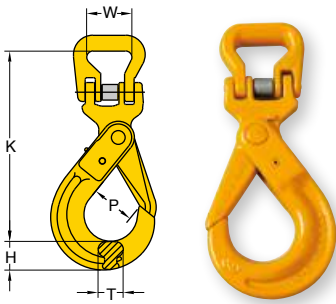



Item No.	Working Load Limit		For Grade 80 Chain	Dimensions (inch)					N.W.
	lbs*	tonnes*	inch	H	K	P	T	W	lbs
8-028-06	2,500	1.12	7/32	0.75	5.43	1.14	0.59	1.54	1.3
8-028-07	4,500	2.0	1/4-5/16	0.94	6.65	1.34	0.79	1.57	2.4
8-028-10	7,100	3.15	3/8	1.19	7.72	1.77	1.02	1.85	4.0
8-028-13	12,000	5.3	1/2	1.57	9.96	2.13	1.19	2.09	7.9
8-028-16	18,100	8.0	5/8	1.93	12.00	2.44	1.42	2.64	15.2
8-028-20	28,300	12.5	3/4	2.36	12.91	3.54	1.91	3.15	23.6
8-028-22	34,200	15.0	7/8	2.48	16.38	3.14	2.12	4.92	39.0
8-028-26	47,700	21.2	1	2.72	18.07	3.90	2.20	5.91	53.1

★ Design factor 4:1 proof tested and certified.

YOKE Roundsling Self Locking Hook is designed in a way to solve your synthetic end-fitting problems.

The Roundsling Self Locking Hook presents following utmost benefits :

1. The Round Shape is designed to provide great protection to your synthetic roundsling on everyloading.
2. Offer complete range of hooks from 1 tonnes up to 21.2 tonnes.
3. Assembly is fast and easy with only a hammer required.
4. The hook with Self Locking function meets real safe and safer required.
5. Acquired  certificate approved by BG  German company.



Shackle Swivel Self Hook. Code "EH"

with Brass Bushing

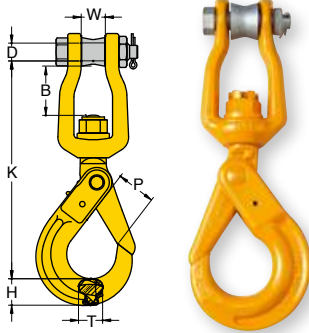

Item No.	Working Load Limit		For Grade 80 Chain inch	Dimensions (inch)							N.W. lbs
	lbs*	tonnes*		B	D	H	K	P	T	W	
8-020-07	4,500	2.0	9/16-5/8	1.77	0.75	0.94	8.03	1.34	0.79	0.83	3.1
8-020-10	7,100	3.15	3/4	2.36	0.79	1.19	9.57	1.77	1.02	1.06	6.0
8-020-13	12,000	5.3	7/8-1	2.95	0.87	1.57	12.09	2.13	1.19	1.34	11.5

★ Design factor 4:1 proof tested and certified.
Tested acc. to EN 1677

⚠ **WARNING INFORMATION:** This hook is a positioning device and is not intended to rotate under load. For swivel hooks designed to rotate under load, see p.147 8-020N.

Shackle Swivel Self Hook. Code " EHN "

with Ball Bearing, which performs full swivel under load

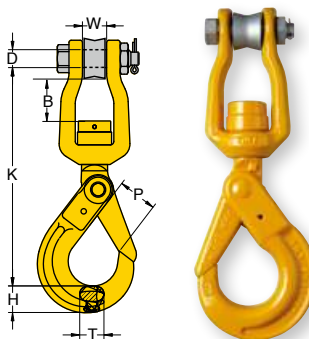

Item No.	Working Load Limit		For Grade 80 Chain inch	Dimensions (inch)							N.W. lbs
	lbs*	tonnes*		B	D	H	K	P	T	W	
8-020N-07	4,500	2.0	9/16-5/8	1.77	0.75	0.94	8.03	1.34	0.79	0.83	3.1
8-020N-10	7,100	3.15	3/4	2.36	0.79	1.19	9.57	1.77	1.02	1.06	6.2
8-020N-13	12,000	5.3	7/8-1	2.95	0.87	1.57	12.09	2.13	1.19	1.34	11.7

★ Design factor 4:1 proof tested and certified.
Tested acc. to EN 1677

Shackle Swivel Hook. Code " EHY "

with Brass Bushing

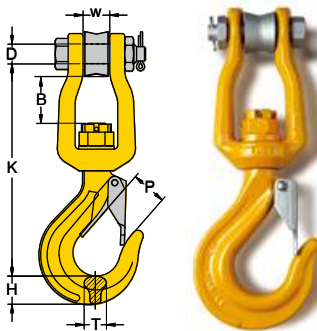

Item No.	Working Load Limit		For Grade 80 Chain inch	Dimensions (inch)							N.W. lbs
	lbs*	tonnes*		B	D	H	K	P	T	W	
8-021-07	4,500	2.0	9/16-5/8	1.77	0.75	0.87	6.77	1.02	0.71	0.83	2.4
8-021-10	7,100	3.15	3/4	2.36	0.79	1.14	8.43	1.42	0.91	1.06	5.1
8-021-13	12,000	5.3	7/8-1	2.95	0.87	1.38	10.43	1.65	1.10	1.34	9.5

★ Design factor 4:1 proof tested and certified.
Tested acc. to EN 1677

⚠ **WARNING INFORMATION:** This hook is a positioning device and is not intended to rotate under load. For swivel hooks designed to rotate under load, see p.147 8-021N.

Shackle Swivel Hook. Code " EHYN "

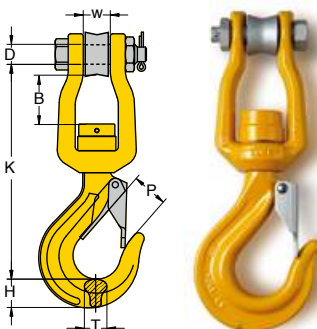

with Ball Bearing, which performs full swivel under load



Item No.	Working Load Limit		For Grade 80 Chain inch	Dimensions (inch)							N.W. lbs
	lbs*	tonnes*		B	D	H	K	P	T	W	
8-021N-07	4,500	2.0	9/16-5/8	1.77	0.75	0.87	6.77	1.02	0.71	0.83	2.4
8-021N-10	7,100	3.15	3/4	2.36	0.79	1.14	8.43	1.42	0.91	1.06	5.1
8-021N-13	12,000	5.3	7/8-1	2.95	0.87	1.38	10.43	1.65	1.10	1.34	9.7

★ Design factor 4:1 proof tested and certified.
Tested acc. to EN 1677

YOKE Insulation Solution

- YOKE Insulated Swivel is designed for winch protection in overhead crane during welding operations.
- Heavy hoisting with a strong but lightweight system.
- Individual swivels & components are 100% proof load tested to a minimum of 2.5 times the working load limit.
- All Swivels are individually tested during manufacturing to assure 1000 Volts insulating property. Test certificate is packaged with each unit shipped.
- YOKE Insulated Swivels are designed with ball bearing which performs to fully swivel under Load.
- Acquired  certificate approved by Deutsche Gesetzliche Unfallversicherung (DGUV) .



Coupling Self Locking Hook. Code "YL"

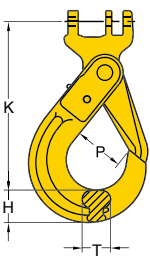



Item No.	Working Load Limit		For Grade 80 Chain	Dimensions (inch)				N.W.
	lbs*	tonnes*	inch	H	K	P	T	lbs
8-023-06	2,500	1.12	7/32	0.75	4.12	1.14	0.59	1.1
8-023-07	4,500	2.0	1/4-5/16	0.94	5.35	1.34	0.79	1.8
8-023-10	7,100	3.15	3/8	1.19	6.06	1.77	1.02	3.1
8-023-13	12,000	5.3	1/2	1.57	7.95	2.13	1.19	6.4
8-023-16	18,100	8.0	5/8	1.93	9.53	2.44	1.42	11.9
8-023-20	28,300	12.5	3/4	2.36	10.12	3.54	1.91	17.9
8-023-22	34,200	15.0	7/8	2.48	11.97	3.15	2.12	24.7
8-023-26	47,700	21.2	1	2.72	12.95	3.90	2.20	32.2

★ Design factor 4:1 proof tested and certified.

Tested acc. to EN 1677

YOKE's innovative, fine design with " **Coupling Pin** " system hook is able to solve any of your problems in Chain, Wire Rope and Synthetic Slings.

The hook :

1. Create safer lifting with the use of " Self Locking " system.
2. Assembly is fast and easy with only a hammer required.
3. Acquired  certificate approved by BG  German company.
4. **Patent** :Taiwan, China, France, Germany, Italy, Japan,USA, Switzerland.

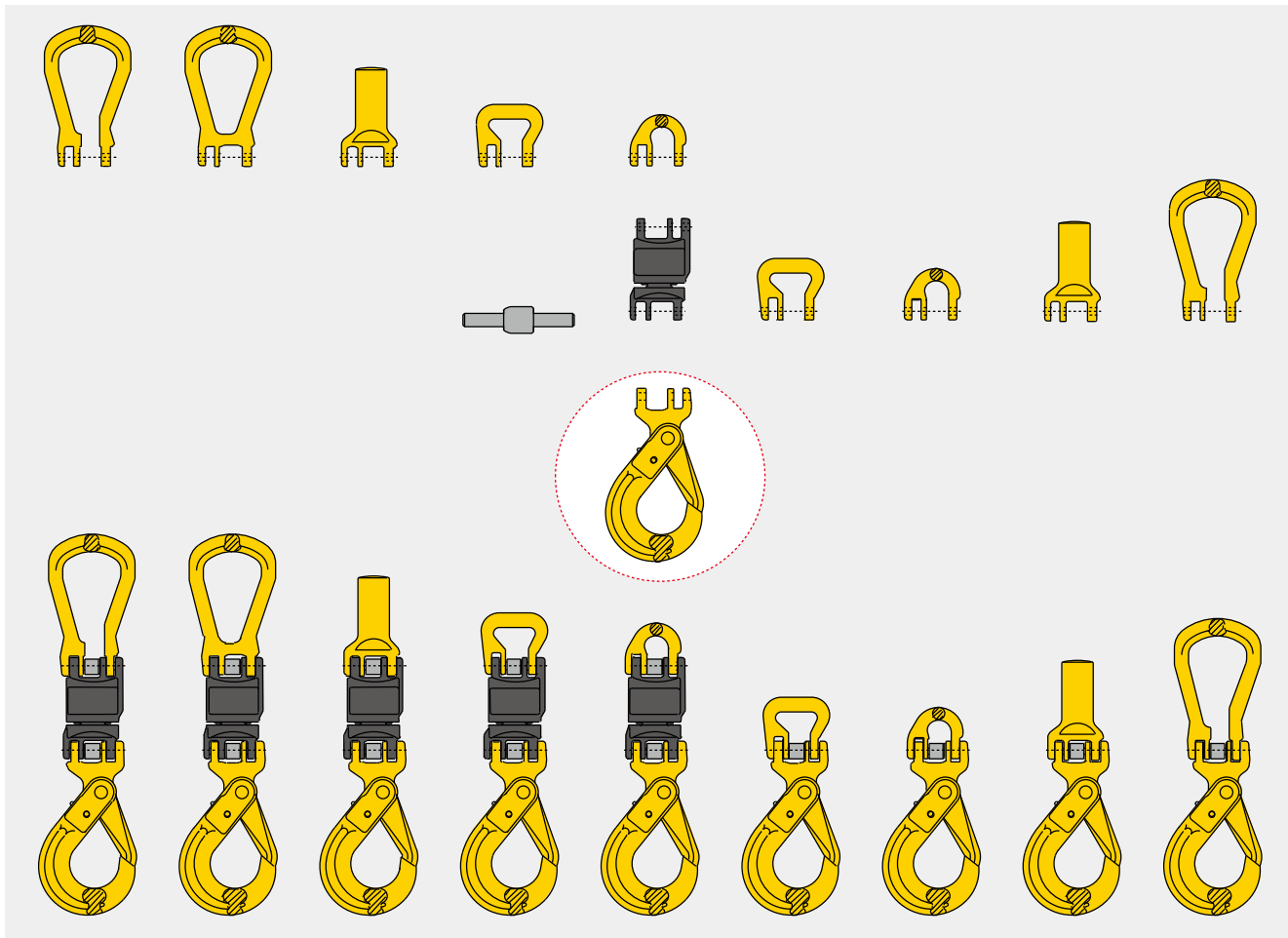

Insulated Blank Swivels. Code "BSI"

with Ball Bearing

Individually tested to resist 1000 Volts insulated with Test Certificate.

Design for protection of overhead crane during welding operations on suspended loads.

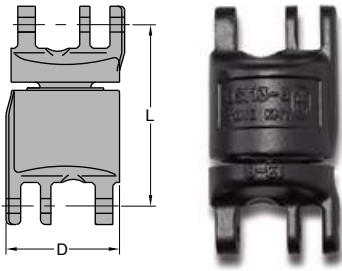

1000 Volts Resistance

Item No.	Working Load Limit		For Grade 80 Chain	Dimensions (inch)		N.W.
	lbs*	tonnes*	inch	D	L	lbs
8-088-07	4,500	2.0	1/4-5/16	1.97	2.95	1.1
8-088-10	7,100	3.15	3/8	2.44	3.70	2.4
8-088-13	12,000	5.3	1/2	3.03	4.84	5.1
8-088-16	18,100	8.0	5/8	3.70	5.63	9.3
8-088-20	28,300	12.5	3/4	4.29	6.46	14.1

★ Design factor 4:1 proof tested and certified.
Tested acc. to EN 1677

Coupling Master Link. Code "EC"

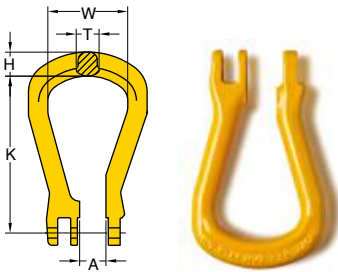

Item No.	Working Load Limit		For Grade 80 Chain	Dimensions (inch)					N.W.
	lbs*	tonnes*	inch	A	H	K	T	W	lbs
8-051-07	4,500	2.0	1/4-5/16	0.59	0.59	3.94	0.59	1.97	0.7
8-051-10	7,100	3.15	3/8	0.79	0.75	5.00	0.75	2.56	1.5
8-051-13	12,000	5.3	1/2	0.98	0.87	5.71	0.93	2.83	2.2
8-051-16	18,100	8.0	5/8	1.18	1.02	6.85	0.98	3.15	3.5
8-051-20	28,300	12.5	3/4	1.42	1.42	7.95	1.22	4.09	6.6

★ Design factor 4:1 proof tested and certified.
Tested acc. to EN 1677

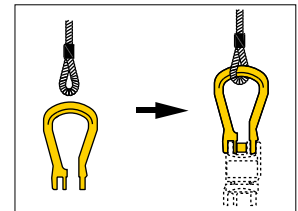

Closed Coupling Master Link. Code "ECO"

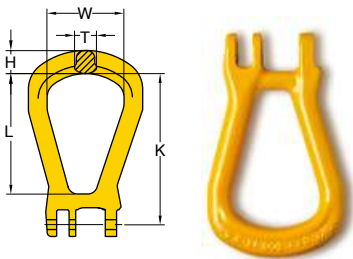

Item No.	Working Load Limit		For Grade 80 Chain	Dimensions (inch)					N.W.
	lbs*	tonnes*	inch	H	K	L	T	W	lbs
8-052-07	4,500	2.0	1/4-5/16	0.59	3.94	3.07	0.59	1.97	0.7
8-052-10	7,100	3.15	3/8	0.75	5.00	3.98	0.75	2.56	1.5
8-052-13	12,000	5.3	1/2	0.87	5.71	4.45	0.91	2.83	2.4
8-052-16	18,100	8.0	5/8	1.02	6.85	5.39	0.98	3.15	3.8
8-052-20	28,300	12.5	3/4	1.42	7.95	6.50	1.22	4.09	6.6

★ Design factor 4:1 proof tested and certified.
Tested acc. to EN 1677

Shank Coupling. Code "EA"

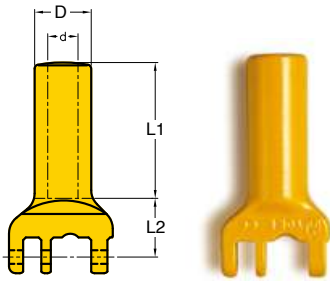

Item No.	Working Load Limit		For Grade 80 Chain	Dimensions (inch)				N.W.
	lbs*	tonnes*	inch	D	d min.**	L1	L2	lbs
8-050-07	4,500	2.0	1/4-5/16	1.18	0.51	2.72	0.91	1.1
8-050-10	7,100	3.15	3/8	1.38	0.63	2.76	1.26	1.5
8-050-13	12,000	5.3	1/2	1.65	0.78	4.13	1.54	3.5
8-050-16	18,100	8.0	5/8	1.97	0.98	4.72	1.81	5.7
8-050-20	28,300	12.5	3/4	2.95	1.18	3.54	2.32	12.4

** d min.: the smallest shank dimension after machining.

Note: After machining the shank, proof loading must be carried out.

Coupling Sling Hook. Code "EB"

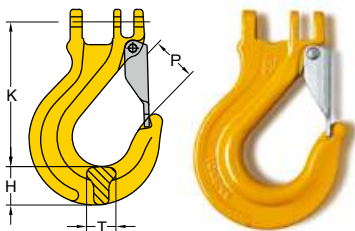

Item No.	Working Load Limit		For Grade 80 Chain	Dimensions (inch)				N.W.
	lbs*	tonnes*	inch	H	K	P	T	lbs
8-055-07	4,500	2.0	1/4-5/16	0.91	3.66	1.18	0.75	0.9
8-055-10	7,100	3.15	3/8	1.22	4.53	1.42	0.91	2.0
8-055-13	12,000	5.3	1/2	1.42	5.55	1.65	1.10	4.0
8-055-16	18,100	8.0	5/8	1.77	6.54	1.85	1.26	6.6
8-055-20	28,300	12.5	3/4	1.89	7.52	2.05	1.69	10.4

★ Design factor 4:1 proof tested and certified.

Tested acc. to EN 1677

Round Sling Coupling. Code "YW"

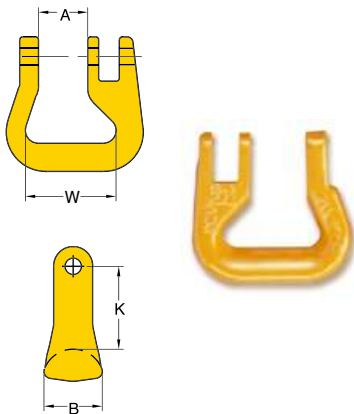

Item No.	Working Load Limit		For Grade 80 Chain	Dimensions (inch)				N.W.
	lbs*	tonnes*	inch	A	B	K	W	lbs
8-053-06	2,500	1.12	7/32	0.59	0.87	1.30	1.54	0.4
8-053-07	4,500	2.0	1/4-5/16	0.71	0.94	1.30	1.57	0.4
8-053-10	7,100	3.15	3/8	0.98	1.14	1.65	1.85	0.9
8-053-13	12,000	5.3	1/2	1.18	1.38	2.01	2.09	1.5
8-053-16	18,100	8.0	5/8	1.42	1.73	2.48	2.64	2.9
8-053-20	28,300	12.5	3/4	1.65	2.05	2.87	3.15	4.6
8-053-22	34,200	15.0	7/8	1.97	2.83	4.37	4.92	12.6
8-053-26	47,700	21.2	1	2.17	3.39	5.08	5.91	20.1
8-053-32	72,300	31.5	1-1/4	2.72	3.35	6.50	7.48	29.5

★ Design factor 4:1 proof tested and certified.

Half Coupling Link. Code "BST"

with Coupling Pin and Sleeve Locking

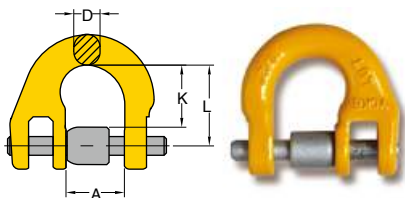

Item No.	Working Load Limit		For Grade 80 Chain	Dimensions (inch)				N.W.
	lbs*	tonnes*	inch	A	D	K	L	lbs
8-054-06	2,500	1.12	7/32	0.59	0.28	0.67	0.87	0.2
8-054-07	4,500	2.0	1/4-5/16	0.71	0.35	0.89	1.10	0.2
8-054-10	7,100	3.15	3/8	0.98	0.50	1.06	1.30	0.4
8-054-13	12,000	5.3	1/2	1.18	0.62	1.38	1.77	0.9
8-054-16	18,100	8.0	5/8	1.42	0.75	1.51	1.97	1.3
8-054-20	28,300	12.5	3/4	1.65	0.87	1.81	2.36	2.4
8-054-22	34,200	15.0	7/8	1.93	0.94	2.32	3.00	3.8
8-054-26	47,700	21.2	1	2.19	1.19	2.44	3.20	6.0
8-054-32	72,300	31.5	1-1/4	2.72	1.42	3.11	4.00	11.0

★ Design factor 4:1 proof tested and certified.

Tested acc. to EN 1677



Insulated Swivels

with Shank & Coupling Sling Hook

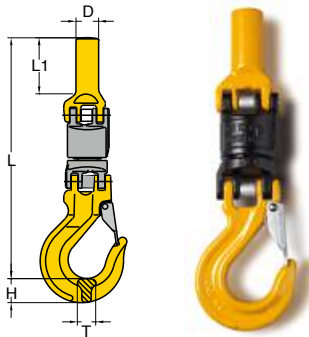

1000 Volts Resistance

Item No.	Working Load Limit		For Grade 80 Chain	Dimensions (inch)					N.W.
	lbs*	tonnes*	inch	D	H	L	L1	T	lbs
8-132-07	4,500	2.0	1/4-5/16	1.18	0.91	10.47	2.72	0.75	4.0
8-132-10	7,100	3.15	3/8	1.38	1.22	12.20	2.76	0.91	6.4
8-132-13	12,000	5.3	1/2	1.65	1.42	16.10	4.13	1.10	12.8
8-132-16	18,100	8.0	5/8	1.97	1.77	18.66	4.72	1.26	22.7
8-132-20	28,300	12.5	3/4	2.95	1.89	19.76	3.54	1.69	37.7

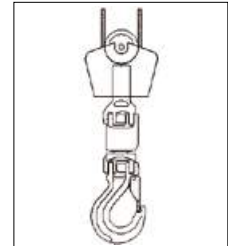

★ Design factor 4:1 proof tested and certified

Insulated Swivels

with Shank & Coupling Self Locking Hook

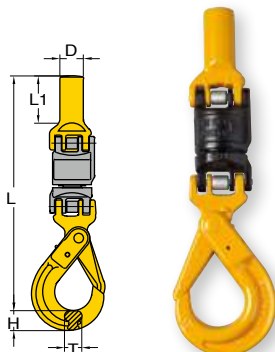

1000 Volts Resistance

Item No.	Working Load Limit		For Grade 80 Chain	Dimensions (inch)					N.W.
	lbs*	tonnes*	inch	D	H	L	L1	T	lbs
8-121-07	4,500	2.0	1/4-5/16	1.16	0.94	12.20	2.72	0.79	5.1
8-121-10	7,100	3.15	3/8	1.38	1.19	13.78	2.76	1.02	7.3
8-121-13	12,000	5.3	1/2	1.65	1.57	18.50	4.13	1.19	15.4
8-121-16	18,100	8.0	5/8	1.97	1.93	21.69	4.72	1.42	29.1
8-121-20	28,300	12.5	3/4	2.95	2.44	22.36	3.54	1.91	46.3

★ Design factor 4:1 proof tested and certified

Insulated Swivels

with Half Link & Coupling Self Locking Hook

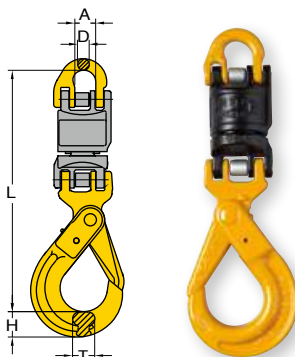

1000 Volts Resistance

Item No.	Working Load Limit		For Grade 80 Chain	Dimensions (inch)					N.W.
	lbs*	tonnes*	inch	A	D	H	L	T	lbs
8-122-07	4,500	2.0	1/4-5/16	0.71	0.35	0.94	9.41	0.79	4.2
8-122-10	7,100	3.15	3/8	0.99	0.50	1.19	11.10	1.02	6.2
8-122-13	12,000	5.3	1/2	1.19	0.62	1.57	14.61	1.19	13.7
8-122-16	18,100	8.0	5/8	1.42	0.75	1.93	17.13	1.42	24.9
8-122-20	28,300	12.5	3/4	1.65	0.87	2.44	18.98	1.91	37.9

★ Design factor 4:1 proof tested and certified
Tested acc. to EN 1677

Insulated Swivels

with 2 Half Links

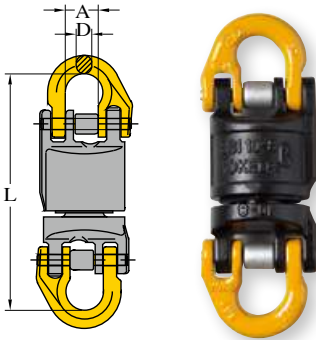

1000 Volts Resistance

Item No.	Working Load Limit		For Grade 80 Chain inch	Dimensions (inch)			N.W. lbs
	lbs*	tonnes*		A	D	L	
8-123-07	4,500	2.0	1/4-5/16	0.71	0.35	5.16	1.5
8-123-10	7,100	3.15	3/8	0.99	0.50	6.38	3.3
8-123-13	12,000	5.3	1/2	1.19	0.62	8.43	7.3
8-123-16	18,100	8.0	5/8	1.42	0.75	9.57	12.8
8-123-20	28,300	12.5	3/4	1.65	0.87	11.22	20.3

★ Design factor 4:1 proof tested and certified
Tested acc. to EN 1677

Insulated Swivels

with Open Master Link & Coupling Self Locking Hook

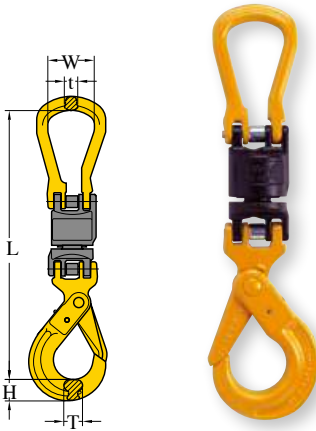

1000 Volts Resistance

Item No.	Working Load Limit		For Grade 80 Chain inch	Dimensions (inch)					N.W. lbs
	lbs*	tonnes*		H	L	T	t	W	
8-124-07	4,500	2.0	1/4-5/16	0.94	12.20	0.79	0.59	1.97	4.6
8-124-10	7,100	3.15	3/8	1.19	14.72	1.02	0.75	2.56	7.3
8-124-13	12,000	5.3	1/2	1.57	18.54	1.19	0.91	2.83	14.6
8-124-16	18,100	8.0	5/8	1.93	22.05	1.42	0.98	3.15	25.6
8-124-20	28,300	12.5	3/4	2.44	24.57	1.91	1.22	4.09	41.7

★ Design factor 4:1 proof tested and certified
Tested acc. to EN 1677

Insulated Swivels

with Open Master Link & Sling Hook

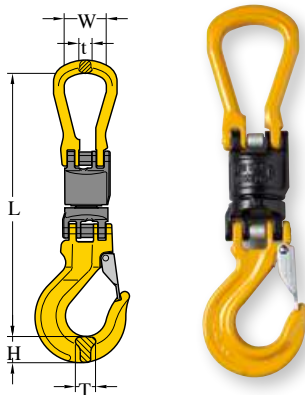

1000 Volts Resistance

Item No.	Working Load Limit		For Grade 80 Chain inch	Dimensions (inch)					N.W. lbs
	lbs*	tonnes*		H	L	T	t	W	
8-125-07	4,500	2.0	1/4-5/16	0.91	10.51	0.75	0.59	1.97	3.5
8-125-10	7,100	3.15	3/8	1.22	13.19	0.91	0.75	2.56	6.2
8-125-13	12,000	5.3	1/2	1.42	16.14	1.10	0.91	2.83	11.9
8-125-16	18,100	8.0	5/8	1.77	19.06	1.26	0.98	3.15	20.3
8-125-20	28,300	12.5	3/4	1.89	21.97	1.69	1.22	4.09	33.1

★ Design factor 4:1 proof tested and certified
Tested acc. to EN 1677



Insulated Swivels

with Open Master Link & Half Link

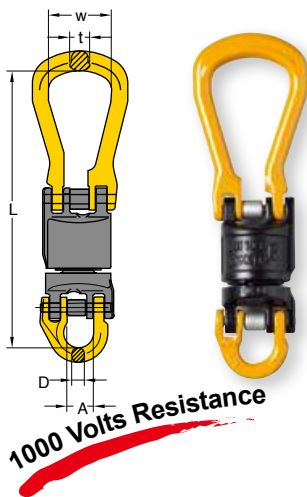

Item No.	Working Load Limit		For Grade 80 Chain inch	Dimensions (inch)					N.W. lbs
	lbs*	tonnes*		A	D	L	t	W	
8-126-07	4,500	2.0	1/4-5/16	0.71	0.35	7.95	0.59	1.97	2.9
8-126-10	7,100	3.15	3/8	0.98	0.50	10.04	0.75	2.56	4.4
8-126-13	12,000	5.3	1/2	1.18	0.62	12.32	0.91	2.83	9.0
8-126-16	18,100	8.0	5/8	1.42	0.75	14.49	0.98	3.15	15.2
8-126-20	28,300	12.5	3/4	1.65	0.87	16.81	1.22	4.09	24.5

★ Design factor 4:1 proof tested and certified
Tested acc. to EN 1677

Insulated Swivels

with Half Link & Web Sling Connector

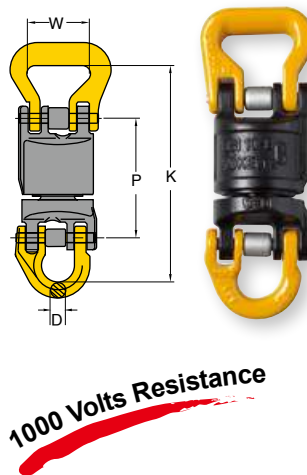

Item No.	Working Load Limit		For Grade 80 Chain inch	Dimensions (inch)				N.W. lbs
	lbs*	tonnes*		D	K	P	W	
8-130-07	4,500	2.0	1/4-5/16	0.35	5.35	2.99	1.57	1.8
8-130-10	7,100	3.15	3/8	0.50	6.69	3.70	1.85	4.0
8-130-13	12,000	5.3	1/2	0.62	8.62	4.84	2.09	7.9
8-130-16	18,100	8.0	5/8	0.75	10.08	5.59	2.64	14.3
8-130-20	28,300	12.5	3/4	0.87	11.61	6.46	3.15	22.3

★ Design factor 4:1 proof tested and certified

Open Master Link with Half Link

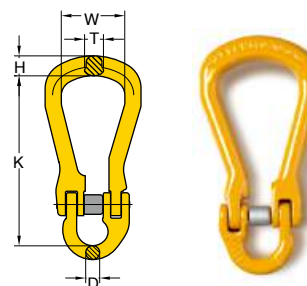

Item No.	Working Load Limit		For Grade 80 Chain inch	Dimensions (inch)					N.W. lbs
	lbs*	tonnes*		D	H	K	T	W	
8-128-07	4,500	2.0	1/4-5/16	0.35	0.59	4.76	0.59	1.97	0.9
8-128-10	7,100	3.15	3/8	0.50	0.75	5.87	0.75	2.56	1.8
8-128-13	12,000	5.3	1/2	0.62	0.87	7.36	0.91	2.83	3.3
8-128-16	18,100	8.0	5/8	0.75	1.02	8.50	0.98	3.15	5.3
8-128-20	28,300	12.5	3/4	0.87	1.42	9.92	1.22	4.09	8.6

★ Design factor 4:1 proof tested and certified
Tested acc. to EN 1677

Closed Master Link with Half Link

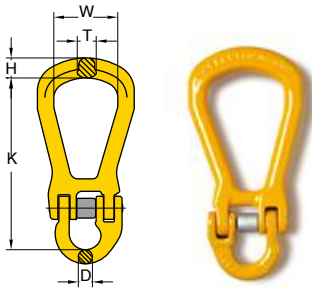

Item No.	Working Load Limit		For Grade 80 Chain	Dimensions (inch)					N.W.
	lbs*	tonnes*	inch	D	H	K	T	W	lbs
8-129-07	4,500	2.0	1/4-5/16	0.35	0.59	4.76	0.59	1.97	0.9
8-129-10	7,100	3.15	3/8	0.50	0.75	5.86	0.75	2.56	2.0
8-129-13	12,000	5.3	1/2	0.62	0.87	7.36	0.91	2.83	3.3
8-129-16	18,100	8.0	5/8	0.75	1.02	8.50	0.98	3.15	5.3
8-129-20	28,300	12.5	3/4	0.87	1.42	9.92	1.22	4.09	8.6

★ Design factor 4:1 proof tested and certified
Tested acc. to EN 1677

Sling Hook with Half Link

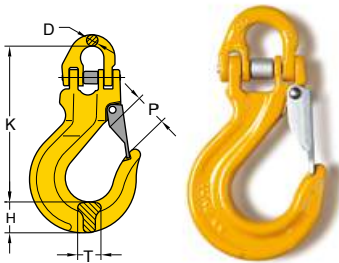

Item No.	Working Load Limit		For Grade 80 Chain	Dimensions (inch)					N.W.
	lbs*	tonnes*	inch	D	H	K	P	T	lbs
8-131-07	4,500	2.0	1/4-5/16	0.35	0.91	4.84	1.18	0.75	1.3
8-131-10	7,100	3.15	3/8	0.50	1.22	5.87	1.42	0.91	2.4
8-131-13	12,000	5.3	1/2	0.62	1.42	7.36	1.65	1.10	4.9
8-131-16	18,100	8.0	5/8	0.75	1.77	8.50	1.85	1.26	9.9
8-131-20	28,300	12.5	3/4	0.87	1.89	9.92	2.05	1.69	15.7

★ Design factor 4:1 proof tested and certified
Tested acc. to EN 1677

Coupling Self Locking Hook with Open Master Link

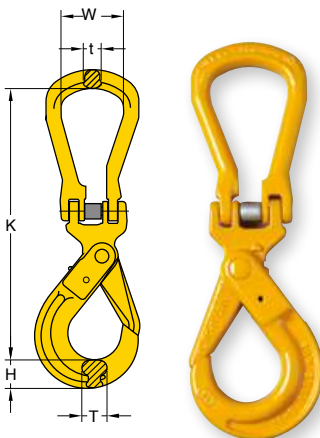

Item No.	Working Load Limit		For Grade 80 Chain	Dimensions (inch)					N.W.
	lbs*	tonnes*	inch	H	K	T	t	W	lbs
8-127-07	4,500	2.0	1/4-5/16	0.94	8.98	0.79	0.59	1.97	2.7
8-127-10	7,100	3.15	3/8	1.19	10.55	1.02	0.75	2.56	4.6
8-127-13	12,000	5.3	1/2	1.57	13.50	1.19	0.91	2.83	8.6
8-127-16	18,100	8.0	5/8	1.93	16.06	1.42	0.98	3.15	16.5
8-127-20	28,300	12.5	3/4	2.44	17.64	1.91	1.22	4.09	25.6

★ Design factor 4:1 proof tested and certified
Tested acc. to EN 1677

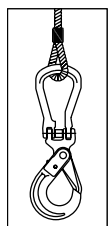

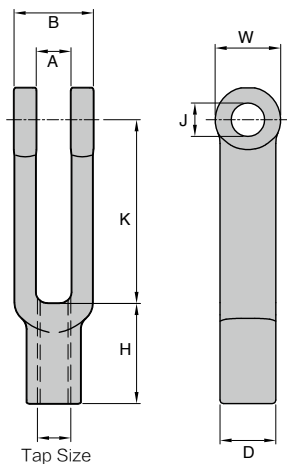

- Forged, low carbon steel.
- Adjustable Yoke End (also) called "clevis ends" are typically assembled to the end of a rod, pipe, tube or cable linkage and are then attached via a clevis pin to a mounting point.

Yoke End (clevis end)

Threaded

Item No.	Tap Size	Dimensions (inch)							N.W.
		A	B	D	H	J	K	W	lbs
8-9400-05	No.10 — 32UNF	0.20	0.45	0.32	0.57	0.19	1.03	0.37	0.02
8-9400-06	1/ 4 — 28UNF	0.29	0.63	0.42	0.75	0.25	1.25	0.19	0.07
8-9400-08	5/16 — 24UNF	0.35	0.76	0.50	0.81	0.31	1.44	0.60	0.11
8-9400-10	3/ 8 — 24UNF	0.44	0.88	0.63	0.87	0.37	1.63	0.69	0.18
8-9400-11	7/16 — 20UNF	0.50	1.01	0.72	0.99	0.44	1.89	0.81	0.26
8-9400-13	1/ 2 — 20UNF	0.56	1.13	0.81	1.11	0.50	1.89	0.94	0.35
8-9400-16	5/ 8 — 18UNF	0.69	1.38	1.06	1.20	0.63	3.73	1.19	0.86

Item No.	Tap Size	Dimensions (mm)							N.W.
		A	B	D	H	J	K	W	kg
8-9400-05	No.10 — 32UNF	5	11	8	14	5	26	9	0.01
8-9400-06	1/ 4 — 28UNF	7	16	11	19	6	32	12	0.03
8-9400-08	5/16 — 24UNF	9	19	13	21	8	37	15	0.05
8-9400-10	3/ 8 — 24UNF	11	22	16	22	10	41	18	0.08
8-9400-11	7/16 — 20UNF	13	26	18	25	11	48	21	0.12
8-9400-13	1/ 2 — 20UNF	14	29	21	28	13	48	24	0.16
8-9400-16	5/ 8 — 18UNF	17	35	27	31	16	95	30	0.39

DATM

Offshore Lifting

Offshore Container Lifting Operation.

YOKE[®]

YOKE[®]

DA[™]
Offshore Lifting

Safety is our first priority[™]

DNV 2.7-1 TYPE APPROVAL

Offshore Container Lifting Operation



DNV-GL

TYPE APPROVAL CERTIFICATE



Certificate No:
S-8059
File No:
911.53
Job Id:
262.1-016068-3

This is to certify:**That the Lifting set for Offshore containers and Portable Offshore Units**

with type designation(s)

Bolt Pin Anchor Shackles - Type DA-808 - Design Temperature -40°C**Bolt Pin Anchor Shackles - Type DA-838 - Design Temperature -40°C**

Issued to

Yoke Industrial Corp.
Taichung, Taiwan

is found to comply with

DNV 2.7-1 Offshore Containers (2013)**DNVGL-ST-E273 Standard 2.7-3 Portable offshore units (2016)****EN 12079-2 Offshore containers and associated lifting sets – Part 2: Lifting sets Design, manufacture and marking****EN 13889 Forged steel shackles for general lifting purposes - Dee shackles and Bow shackles - Grade 6 - Safety****IMO/MSC Circular 860****Application :****Shackles for Lifting Sets for Offshore Containers and Portable Offshore Units**This Certificate is valid until **2019-06-30**.Issued at **Høvik** on **2017-05-26**DNV GL local station: **Kaohsiung**Approval Engineer: **Igor Antonijevic**for **DNV GL**Digitally Signed By: Hals,
Inger-Helene

Signing Date: 30.05.2017

Location: Høvik, Norway

Inger-Helene Hals
Head of Section

This Certificate is subject to terms and conditions overleaf. Any significant change in design or construction may render this Certificate invalid. The validity date relates to the Type Approval Certificate and not to the approval of equipment/systems installed. If any person suffers loss or damage which is proven to have been caused by any negligent act or omission of the Society, then the Society shall pay compensation to such person for his proven direct loss or damage. However, the compensation shall not exceed an amount equal to ten times the fee charged for the service in question. The maximum compensation shall never exceed USD 2 million. In this provision the "Society" shall mean DNV GL AS as well as all its direct and indirect owners, affiliates, subsidiaries, directors, officers, employees, agents and any other person or entity acting on behalf of DNV GL AS.

**DNV·GL**Certificate No:
TAS000005Z

TYPE APPROVAL CERTIFICATE

This is to certify:**That the Lifting set for Offshore containers and Portable Offshore Units**

with type designation(s)

Master Link - Type DA-003, Master Link Assembly - DA-007

Issued to

**Yoke Industrial Corp.
Taichung, Taiwan**

is found to comply with

DNV 2.7-1 Offshore Containers (2013)**DNV Standard for Certification No. 2.7-3 Portable Offshore Units (2011)****EN 1677-4 Components for slings - Safety - Part 4: Links, Grade 8****EN 12079-2 Offshore containers and associated lifting sets Part 2: Lifting sets Design,
manufacture and marking****IMO/MSC Circular 860****Application :****Grade 8 Links for Lifting Sets for Offshore Containers or Portable Offshore Units**This Certificate is valid until **2020-10-20**.Issued at **Høvik** on **2015-10-21**DNV GL local station: **Kaohsiung**Approval Engineer: **Nina Thorvaldsen Moberg**for **DNV GL**

Digitally Signed By: Hals, Inger-Helene

Location: DNV GL Høvik, Norway

Signing Date: 2015-10-30

**Inger-Helene Hals
Head of Section**

This Certificate is subject to terms and conditions overleaf. Any significant change in design or construction may render this Certificate invalid.
The validity date relates to the Type Approval Certificate and not to the approval of equipment/systems installed.

Stu



DNV·GL

Certificate No:
TAS00000T4

TYPE APPROVAL CERTIFICATE

This is to certify:

That the Chain, shackles, swivels, sockets

with type designation(s)
Lifting points DA-271 for offshore cranes

Issued to

Yoke Industrial Corp.
Taichung, Taiwan

is found to comply with
DNV GL standard DNVGL-ST-0378 – Standard for offshore and platform lifting appliances

Application :

Product(s) approved by this certificate is/are accepted for installation on all vessels classed by DNV GL.

This Certificate is valid until **2022-05-29**.

Issued at **Høvik** on **2017-05-30**

DNV GL local station: **Kaohsiung**

Approval Engineer: **Antonio Sendin Alvarez**

for **DNV GL**



Digitally Signed By: aldo.matteucci@dnvgl.com
Location: DNV GL Høvik, Norway
Signing Date: 31.05.2017

Aldo Matteucci
Head of Section

This Certificate is subject to terms and conditions overleaf. Any significant change in design or construction may render this Certificate invalid. The validity date relates to the Type Approval Certificate and not to the approval of equipment/systems installed.



DNV·GL

Certificate No:
TAS000011K

TYPE APPROVAL CERTIFICATE

This is to certify:

That the Hook

with type designation(s)
Hooks DA-025 & DA-027N

Issued to
Yoke Industrial Corp.
Taichung, Taiwan

is found to comply with
DNV GL standard DNVGL-ST-0378 – Standard for offshore and platform lifting appliances

Application :

Product(s) approved by this certificate is/are accepted for installation on all vessels classed by DNV GL.

Issued at **Høvik** on **2017-05-31**

This Certificate is valid until **2022-05-30**.
DNV GL local station: **Kaohsiung**

Approval Engineer: **Antonio Sendin Alvarez**

for **DNV GL**



Digitally Signed By: aldo.matteucci@dnvgl.com
Location: DNV GL Høvik, Norway
Signing Date: 01.06.2017

Aldo Matteucci
Head of Section

This Certificate is subject to terms and conditions overleaf. Any significant change in design or construction may render this Certificate invalid. The validity date relates to the Type Approval Certificate and not to the approval of equipment/systems installed.



Form code: TA 251

Revision: 2016-12

www.dnvgl.com

Page 1 of 3

© DNV GL 2014. DNV GL and the Horizon Graphic are trademarks of DNV GL AS.

The Features of YOKE DA™ Offshore Container Lifting Series

YOKE DA™ Series are manufactured to meet the requirements of DNV 2.7-1 for offshore container lifting to fulfill the need for the critical requirements of charpy impact, strength and ductility.

Lower Temperature Demand

YOKE DA™ Series are designed to withstand impacts in extreme environments up to maximum -40° C.

Higher Safety Factors

YOKE DA™ Shackles have a design factor of 6 for Grade 6 Shackles and a design factor of 8 for Grade 8 shackles, and YOKE DA™ Master Link & Assembly have a design factor of 5 to enable them to operate in the harshest environments.

DNV 2.7-1 Specified Test Certificate

Test certificate with material and manufacturing process specified in DNV 2.7-1 for complete traceability.

To perform in the harshest weather and roughest sea conditions, YOKE DA™ Series are specially designed, manufactured and tested for the operating in the offshore container industry.

Determination of

Table 8-1 Determination of Working Load Limit

Rating(kg)	Enhancement factor	Minimum required Working Load Limit(WLLmin)(t)
500	-	7.00
1000	-	7.00
1500	-	7.00
2000	3.500	7.00
2500	2.880	7.20
3000	2.600	7.80
3500	2.403	8.41
4000	2.207	8.83
4500	2.067	9.30
5000	1.960	9.80
5500	1.873	10.30
6000	1.766	10.60
6500	1.733	11.26
7000	1.700	11.90
7500	1.666	12.50
8000	1.633	13.07
8500	1.600	13.60
9000	1.567	14.10
9500	1.543	14.57
10000	1.501	15.01
10500	1.479	15.53
11000	1.457	16.02
11500	1.435	16.50
12000	1.413	16.95
12500	1.931	17.38
13000	1.368	17.79
13500	1.346	18.18
14000	1.324	18.54
14500	1.302	18.88
15000	1.280	19.20
15500	1.267	19.64
16000	1.254	20.06
16500	1.240	20.47
17000	1.227	20.86
17500	1.214	21.24
18000	1.201	21.61
18500	1.188	21.97
19000	1.174	22.31
19500	1.161	22.64
20000	1.148	22.96
20500	1.143	23.44
21000	1.139	23.92
21500	1.135	24.39
22000	1.130	24.86
22500	1.126	25.33
23000	1.121	25.79
23500	1.117	26.25
24000	1.112	26.70
24500	1.108	27.15
25000	1.104	27.59

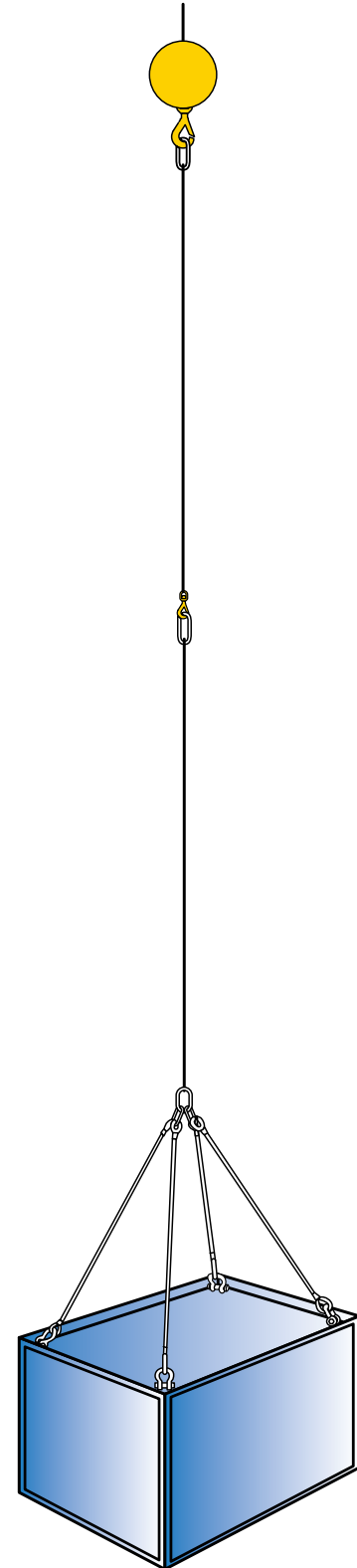

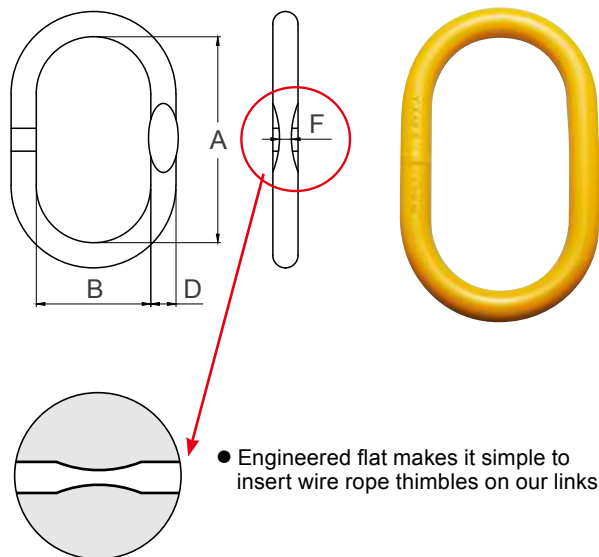

● Engineered flat makes it simple to insert wire rope thimbles on our links.

- Meets the following performance requirements:
 - DNV 2.7-1
 - EN 1677-4
 - ASME B30.26
- Fatigue rated to 20,000 cycles at 1.5 times the Working Load Limit (WLL)
- Charpy test of 42 joules (31ft. lbs.) at -40°C (-40°F) for normal section
- Charpy test of 27 joules (20ft. lbs.) at -40°C (-40°F) for welding section

-40°C

DA Master Link

Item No.	WLL	Proof Load	Dimensions (inch)				N.W.
	β 0-45° tonnes		D	A	B	F	
DA-003F-1310	6.7	164	0.75	6.30	3.54	0.33	2.4
DA-003F-1613	8.5	208	0.88	7.10	3.94	0.41	3.5
DA-003F-1916	11.5	282	1	8.27	4.53	0.53	5.3
DA-003F-20	13.0	319	1.13	10.83	5.71	0.53	8.6
DA-003F-2220	17.0	417	1.25	10.83	5.71	0.61	11.5
DA-003-2622	24.0	588	1.44	11.20	6.10	---	15.2
DA-003-28	28.1	689	1.56	11.80	6.30	---	19.8
DA-003-3226	38.3	939	1.75	13.40	7.10	---	28.2

*Welded Master Link

*Design Factor 5:1

*Proof tested at 2.5 times the WLL

Item No.	WLL	Proof Load	Dimensions (mm)				N.W.
	β 0-45° tonnes		D	A	B	F	
DA-003F-1310	6.7	164	19	160	90	8.5	1.1
DA-003F-1613	8.5	208	22	180	100	10.5	1.6
DA-003F-1916	11.5	282	25	210	115	13.5	2.4
DA-003F-20	13.0	319	28	275	145	13.5	3.9
DA-003F-2220	17.0	417	32	275	145	15.5	5.2
DA-003-2622	24.0	588	36	285	155	---	6.9
DA-003-28	28.1	689	40	300	160	---	9.0
DA-003-3226	38.3	939	45	340	180	---	12.8

*Welded Master Link

*Design Factor 5:1

*Proof tested at 2.5 times the WLL

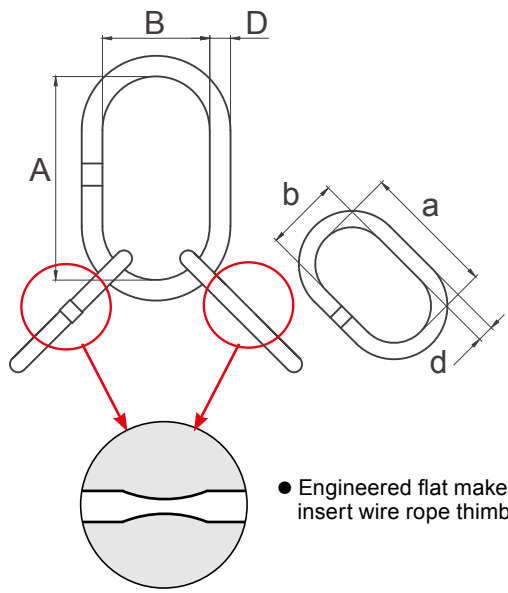

- Meets the following performance requirements:
 - DNV 2.7-1
 - EN 1677-4
 - ASME B30.26
- Fatigue rated to 20,000 cycles at 1.5 times the Working Load Limit (WLL)
- Charpy test of 42 joules (31ft. lbs.) at -40°C (-40°F) for normal section
- Charpy test of 27 joules (20ft. lbs.) at -40°C (-40°F) for welding section

● Engineered flat makes it simple to insert wire rope thimbles on our links.

-40°C

DA Master Link Assembly

Item No.	WLL	Proof Load	Dimensions (inch)							N.W.
	β 0-45° tonnes		D	A	B	d	a	b	F	
DA-007F-10	8.9	218	1	10.83	5.71	0.75	6.30	3.54	0.33	11.5
DA-007F-13	12.9	316	1.13	10.83	5.71	0.88	7.10	3.94	0.41	15.6
DA-007F-16	17.0	417	1.25	10.83	5.71	1	8.27	4.53	0.53	22.1
DA-007-19	23.6	579	1.44	10.83	5.71	1.13	7.48	3.94	---	26.9
DA-007-20	28.1	689	1.56	11.80	6.30	1.25	5.71	5.71	---	42.6
DA-007-22	38.3	939	1.75	13.40	7.10	1.44	11.20	6.10	---	58.7

*Welded Master Link
 *Design Factor 5:1
 *Proof tested at 2.5 times the WLL

Item No.	WLL	Proof Load	Dimensions (mm)							N.W.
	β 0-45° tonnes		D	A	B	d	a	b	F	
DA-007F-10	8.9	218	25	275	145	19	160	90	8.5	5.2
DA-007F-13	12.9	316	28	275	145	22	180	100	10.5	7.1
DA-007F-16	17.0	417	32	275	145	25	210	115	13.5	10.0
DA-007-19	23.6	579	36	275	145	28	190	100	---	12.2
DA-007-20	28.1	689	40	300	160	32	275	145	---	19.3
DA-007-22	38.3	939	45	340	180	36	285	155	---	26.6

*Welded Master Link
 *Design Factor 5:1
 *Proof tested at 2.5 times the WLL

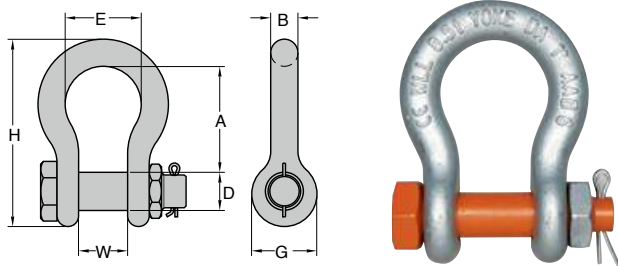

● Meets the following performance requirements:

- DNV 2.7-1
- DNVGL-ST-0378
- EN 13889
- U.S. Fed. Spec. RR-C-271F Type IVA, Grade A, Class 3
- ASME B30.26
- Hot dip galvanized
- Fatigue rated to 20,000 cycles at 1.5 times the Working Load Limit (WLL)
- Charpy test of 42 joules (31ft. lbs.) at - 20°C (- 4°F)

DA 838 Shackle

-40°C

Grade 6

Item No.	Nominal Size	Working Load Limit	Dimensions (inch)							N.W.
			inch	tonnes*	A	B	D	E	G	
DA-838-13	1/2	2.00	1.85	0.52	0.63	1.30	1.18	3.34	0.79	0.9
DA-838-16	5/8	3.25	2.40	0.63	0.75	1.70	1.50	4.17	1.06	1.5
DA-838-19	3/4	4.75	2.83	0.75	0.87	1.97	1.81	5.04	1.30	2.2
DA-838-22	7/8	6.50	3.39	0.87	1.02	2.28	2.09	5.91	1.50	3.7
DA-838-26	1	8.50	3.78	1.02	1.10	2.68	2.40	6.57	1.73	5.3
DA-838-28	1- 1/8	9.50	4.37	1.10	1.26	2.91	2.68	7.52	1.81	7.5
DA-838-32	1- 1/4	12.00	4.76	1.26	1.42	3.30	2.99	8.07	2.12	10.6
DA-838-36	1- 3/8	13.50	5.28	1.42	1.50	3.62	3.31	9.13	2.32	14.3
DA-838-38	1- 1/2	17.00	5.57	1.50	1.77	3.90	3.62	10.00	2.36	19.4
DA-838-45	1- 3/4	25.00	7.00	1.85	2.00	5.00	4.17	12.32	2.87	38.5
DA-838-50	2	35.00	7.76	2.09	2.24	5.75	4.80	13.66	3.27	53.2
DA-838-64	2- 1/2	** 55.00	10.51	2.62	2.76	7.24	5.71	17.83	4.13	95.7
DA-838-76	3	** 85.00	12.99	2.99	3.25	7.87	6.50	21.50	5.00	178.2
DA-838-89	3- 1/2	**120.00	14.65	3.62	3.76	9.02	7.99	24.65	5.24	264.0
DA-838-100	4	**150.00	14.49	4.09	4.25	10.00	9.02	25.71	5.51	336.6

*2t to 35t are type approved of DNV 2.7-1. Minimum Ultimate Load is 6 times the Working Load Limit.

**55t to 150t meet all requirements of DNV 2.7-1. Minimum Ultimate Load is 6 times the Working Load Limit.

Item No.	Nominal Size	Working Load Limit	Dimensions (mm)							N.W.
			mm	tonnes*	A	B	D	E	G	
DA-838-13	13	2.00	47	13	16	33	30	85	20	0.4
DA-838-16	16	3.25	61	16	19	43	38	106	27	0.7
DA-838-19	19	4.75	72	19	22	50	46	126	33	1.0
DA-838-22	22	6.50	86	22	26	58	53	148	38	1.7
DA-838-26	26	8.50	96	26	28	68	61	166	44	2.4
DA-838-28	28	9.50	111	28	32	74	68	190	46	3.4
DA-838-32	32	12.00	121	32	36	84	76	210	54	4.8
DA-838-36	36	13.50	134	36	38	92	84	232	59	6.5
DA-838-38	38	17.00	146	38	44	99	92	254	60	8.8
DA-838-45	45	25.00	178	47	51	127	106	313	73	17.5
DA-838-50	50	35.00	197	53	57	146	122	347	83	24.2
DA-838-64	64	** 55.00	267	66.5	70	184	145	453	105	43.5
DA-838-76	76	** 85.00	330	76	82.5	200	165	546	127	81.0
DA-838-89	89	**120.00	372	92	95.5	229	203	626	133	120.0
DA-838-100	100	**150.00	368	104	108	254	229	653	140	153.0

*2t to 35t are type approved of DNV 2.7-1. Minimum Ultimate Load is 6 times the Working Load Limit.

**55t to 150t meet all requirements of DNV 2.7-1. Minimum Ultimate Load is 6 times the Working Load Limit.

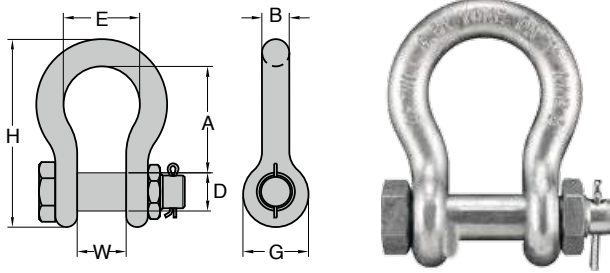

● Meets the following performance requirements:

- DNV 2.7-1
- DNVGL-ST-0378
- EN 13889
- U.S. Fed. Spec. RR-C-271F Type IVA, Grade A, Class 3
- ASME B30.26

● Hot dip galvanized

● Fatigue rated to 20,000 cycles at 1.5 times the Working Load Limit (WLL)

● Charpy test of 42 joules (31ft. lbs.) at - 40°C (- 40°F)

DA 808 Shackle

-40°C

Grade 8

Item No.	Nominal Size	Working Load Limit	Dimensions (inch)							N.W.
	inch		tonnes*	A	B	D	E	G	H	W
DA-808-13	1/2	2.00	1.85	0.52	0.63	1.30	1.18	3.34	0.79	0.9
DA-808-16	5/8	3.25	2.40	0.63	0.75	1.70	1.50	4.17	1.06	1.5
DA-808-19	3/4	4.75	2.83	0.75	0.87	1.97	1.81	5.04	1.30	2.2
DA-808-22	7/8	6.50	3.39	0.87	1.02	2.28	2.09	5.91	1.50	3.7
DA-808-26	1	8.50	3.78	1.02	1.10	2.68	2.40	6.57	1.73	5.3
DA-808-28	1- 1/8	9.50	4.37	1.10	1.26	2.91	2.68	7.52	1.81	7.5
DA-808-32	1- 1/4	12.00	4.76	1.26	1.42	3.30	2.99	8.07	2.12	10.6
DA-808-36	1- 3/8	13.50	5.28	1.42	1.50	3.62	3.31	9.13	2.32	14.3
DA-808-38	1- 1/2	17.00	5.57	1.50	1.77	3.90	3.62	10.00	2.36	19.4
DA-808-45	1- 3/4	25.00	7.00	1.85	2.00	5.00	4.17	12.32	2.87	38.5
DA-808-50	2	35.00	7.76	2.09	2.24	5.75	4.80	13.66	3.27	53.2
DA-808-64	2- 1/2	** 85.00	10.51	2.62	2.76	7.24	5.71	17.83	4.13	95.7
DA-808-76	3	**120.00	12.99	2.99	3.25	7.87	6.50	21.50	5.00	178.2
DA-808-89	3- 1/2	**150.00	14.65	3.62	3.76	9.02	7.99	24.65	5.24	264.0
DA-808-100	4	**175.00	14.49	4.09	4.25	10.00	9.02	25.71	5.51	336.6

*2t to 35t are type approved of DNV 2.7-1. Minimum Ultimate Load is 8 times the Working Load Limit.

**85t to 175t meet all requirements of DNV 2.7-1. Minimum Ultimate Load is 5.4 times the Working Load Limit.

Item No.	Nominal Size	Working Load Limit	Dimensions (mm)							N.W.
	mm		tonnes*	A	B	D	E	G	H	W
DA-808-13	13	2.00	47	13	16	33	30	85	20	0.4
DA-808-16	16	3.25	61	16	19	43	38	106	27	0.7
DA-808-19	19	4.75	72	19	22	50	46	126	33	1.0
DA-808-22	22	6.50	86	22	26	58	53	148	38	1.7
DA-808-26	26	8.50	96	26	28	68	61	166	44	2.4
DA-808-28	28	9.50	111	28	32	74	68	190	46	3.4
DA-808-32	32	12.00	121	32	36	84	76	210	54	4.8
DA-808-36	36	13.50	134	36	38	92	84	232	59	6.5
DA-808-38	38	17.00	146	38	45	99	92	254	60	8.8
DA-808-45	45	25.00	178	47	51	127	106	313	73	17.5
DA-808-50	50	35.00	197	53	57	146	122	347	83	24.2
DA-808-64	64	** 85.00	267	66.5	70	184	145	453	105	43.5
DA-808-76	76	**120.00	330	76	82.5	200	165	546	127	81.0
DA-808-89	89	**150.00	372	92	95.5	229	203	626	133	120.0
DA-808-100	100	**175.00	368	104	108	254	229	653	140	153.0

*2t to 35t are type approved of DNV 2.7-1. Minimum Ultimate Load is 8 times the Working Load Limit.

**85t to 175t meet all requirements of DNV 2.7-1. Minimum Ultimate Load is 5.4 times the Working Load Limit.

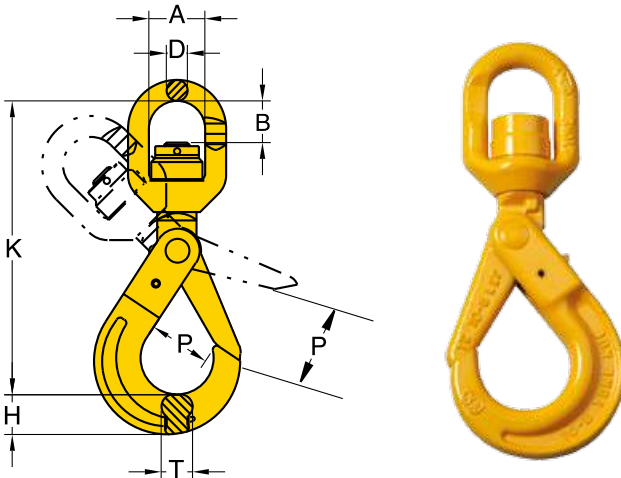

- Forged alloy steel, quenched and tempered.
- Designed with recessed trigger and ball bearing.
- Tested and manufactured in accordance with EN1677-3.
- In accordance with DNVGL-ST-0378.
- Comply with Norsok R002.
- The recessed trigger provides the locking mechanism being protected against inadvertent opening due to entanglement with any obstruction during lifting.
- Design factor 4:1 and 5:1
- Latch mechanism is self locking under loading.

-40°C

DA Swivel Self Locking Hook

With Ball Bearing, which performs full swivel under load.
Requirements acc. To DNV 0378

Item No.	Working Load Limit		Dimensions (inch)							N.W. lbs
	tonnes*		A	B	D	H	K	P	T	
	5:1	4:1								
DA-027N-13W	4.3	5.3	2.40	1.97	0.91	1.54	11.14	2.01	1.18	11
DA-027N-16W	8	10	2.91	3.23	0.98	1.93	14.21	2.36	1.42	13
DA-027N-20	10	12.5	2.91	3.23	0.98	2.56	15.24	2.76	2.09	29
DA-027N-22	15.2	19	3.82	3.74	1.30	2.48	17.99	3.15	1.93	44
DA-027N-26	21.2	26.5	4.84	4.53	1.65	2.72	21.06	3.90	2.20	72
DA-027N-32	25.2	31.5	4.84	4.53	1.65	3.19	22.95	4.72	2.48	85

Item No.	Working Load Limit		Dimensions (mm)							N.W. kg
	tonnes*		A	B	D	H	K	P	T	
	5:1	4:1								
DA-027N-13W	4.3	5.3	61	50	23	39	283	51	30	5.0
DA-027N-16W	8	10	74	82	25	49	361	60	36	6.0
DA-027N-20	10	12.5	74	82	25	65	387	70	53	13.0
DA-027N-22	15.2	19	97	95	33	63	457	80	49	20.0
DA-027N-26	21.2	26.5	123	115	42	69	535	99	56	32.7
DA-027N-32	25.2	31.5	123	115	42	81	583	120	63	38.5

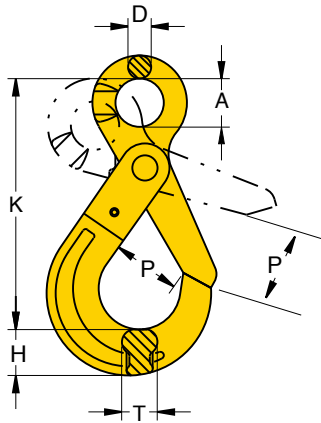

- Forged alloy steel, quenched and tempered.
- Designed with recessed trigger.
- Tested and manufactured in accordance with EN1677-3.
- In accordance with DNVGL-ST-0378.
- Comply with Norsok R002.
- The recessed trigger provides the locking mechanism being protected against inadvertent opening due to entanglement with any obstruction during lifting.
- Design factor 4:1 and 5:1
- Latch mechanism is self locking under loading.

-40°C

DA Eye Self Locking Hook

Requirements acc. To DNV 0378

Item No.	Working Load Limit		Dimensions (inch)						N.W.
	tonnes*		A	D	H	K	P	T	lbs
	5:1	4:1							
DA-025-13	5.3	6.7	1.57	0.63	1.54	8.15	2.01	1.18	6.6
DA-025-16	8.0	10.0	1.97	0.83	1.93	9.92	2.36	1.42	12.8
DA-025-20	12.8	16.0	2.36	0.91	2.56	11.42	2.76	2.09	22.0
DA-025-22	15.2	19.0	2.76	0.94	2.48	12.56	3.15	1.93	27.5
DA-025-26	21.2	26.5	3.15	0.98	2.72	13.50	3.90	2.20	33.0
DA-025-32	26.2	32.8	3.54	1.10	3.19	15.79	4.72	2.48	57.3

Item No.	Working Load Limit		Dimensions (mm)						N.W.
	tonnes*		A	D	H	K	P	T	kg
	5:1	4:1							
DA-025-13	5.3	6.7	40	16	39	207	51	30	3.0
DA-025-16	8.0	10.0	50	21	49	252	60	36	5.8
DA-025-20	12.8	16.0	60	23	65	290	70	53	10.0
DA-025-22	15.2	19.0	70	24	63	319	80	49	12.5
DA-025-26	21.2	26.5	80	25	69	343	99	56	15.0
DA-025-32	26.2	32.8	90	28	81	401	120	63	26.0

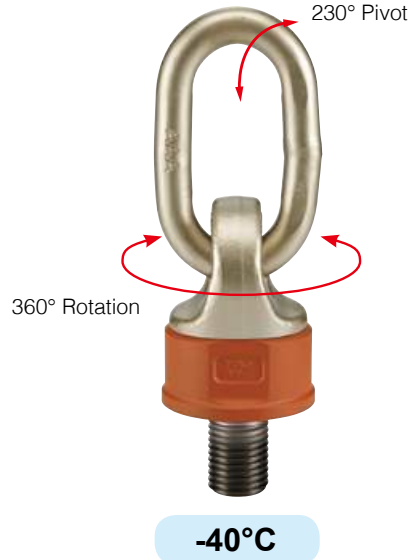
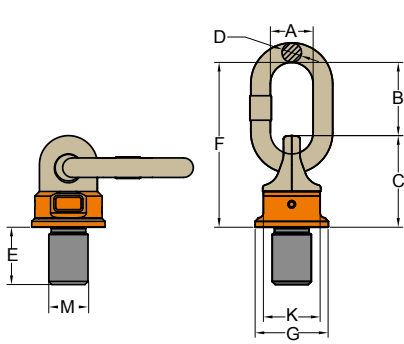

- Pivots more than 230°, rotates through 360° due to its unique ball bearing design. Design factor 4:1 in all directions.
- Manufactured from forged alloy steel, quenched and tempered.
- Manufactured and tested in accordance with EN1677-1 and DNVGL-ST-0378.
- Load rated parts are 100% magnaflux crack detected.
- Individual forged parts and cap screw are traceable to Test Certification.
- Proof tested to 2.5 times the WLL.
- Fatigue rated to 1.5 times the WLL.
- All YOKE Lifting points meet or exceed all the requirements of ASME B30.26.
- Easy to attach or dismantle due to the forged hexagon shaped body of the DA Swivel Point.
- Maximum WLL in axial direction when load ring is aligned.
- Capable of rotating under load. Do not turn continuously in 90 degree direction at full load.

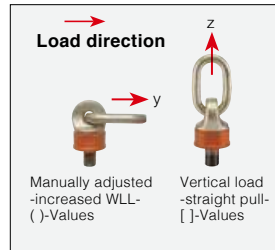
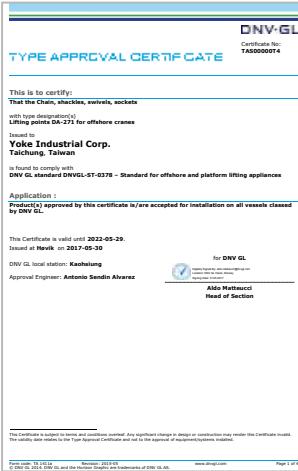

DA Swivel Point Metric Thread (DA-271)

DNVGL-ST-0378
(Offshore crane- Lifting Appliance)



Item No.	Working Load Limit		Thread version			Dimensions (mm)							Torque in Nm	N.W. kg
	(y)	[z]	M	E	Pitch	G	C	K	F	D	B	A		
	tonnes		mm	mm	DIN13				mm					
DA-271-003	0.4	0.6	M 8	12	1.25	35	40	30	72	8	32	29	10 - 40	0.2
DA-271-004	0.6	0.9	M 10	15	1.5	35	40	30	72	8	32	29	10 - 40	0.2
DA-271-006	0.7	1.2	M 12	18	1.75	40	45	36	95	10	50	35	15 - 40	0.3
DA-271-013	1.5	2.6	M 16	24	2	46	54	41	104	13	50	38	45 - 130	0.5
DA-271-020	2.5	4	M 20	30	2.5	62	68	55	122	13	54	38	100 - 170	1.0
DA-271-035	4	7	M 24	36	3	78	88	70	154	19	66	40	190 - 280	2.2
DA-271-060	6	10	M 30	46	3.5	90	120	80	206	22	86	50	270 - 600	4.5
DA-271-080	10	15	M 36	55	4	90	120	80	206	22	86	50	270 - 600	4.6
DA-271-120	13	17	M 42	64	4.5	98	122	84	235	25	110	65	350 - 800	5.5
DA-271-130	16	18	M 48	73	5	98	122	84	235	25	110	65	350 - 800	6.1
DA-271-140	20	25	M 52	79	5	120	150	94	270	32	120	70	350 - 900	10.5
DA-271-160	22	28	M 56	85	5.5	120	150	94	270	32	120	70	350 - 900	10.7
DA-271-161	22	28	M 64	95	6	120	150	94	270	32	120	70	500 - 1000	11.6

*Design factor 4:1 proof tested and certified.



-40°C



Kind of attachment	1		2		2		2		3-4		3-4	
	1	2	1	2	2	2	2	3-4	3-4	3-4	3-4	
Number of legs	1		2		1		2		3-4		3-4	
Load direction	0°		0°		90°		90°		0 - 45°		45° - 60°	
Item No.	Thread	WLL(t)										
DA-271-003	M 8	0.6	1.2	0.4	0.8	0.4	0.3	0.3	0.6	0.4	0.3	
DA-271-004	M10	0.9	1.8	0.6	1.2	0.6	0.4	0.4	0.9	0.6	0.4	
DA-271-006	M12	1.2	2.4	0.7	1.5	0.8	0.6	0.6	1.2	0.9	0.6	
DA-271-013	M16	2.6	5.2	1.5	3	1.8	1.3	1.3	2.7	1.9	1.3	
DA-271-020	M20	4	8	2.5	5	2.8	2	2	4.2	3	2	
DA-271-035	M24	7	14	4	8	4.9	3.5	3.5	7.3	5.2	3.5	
DA-271-060	M30	10	20	6	12	7	5	5	10.5	7.5	5	
DA-271-080	M36	15	30	10	20	14	10	10	21	15	10	
DA-271-120	M42	17	34	13	26	18.2	13	13	27.3	19.5	13	
DA-271-130	M48	18	36	14	28	19.6	14	14	29.4	21	14	
DA-271-140	M52	25	50	20	40	28	20	20	42	30	20	
DA-271-160	M56	28	56	20	40	28	20	20	42	30	20	
DA-271-161	M64	28	56	20	40	28	20	20	42	30	20	

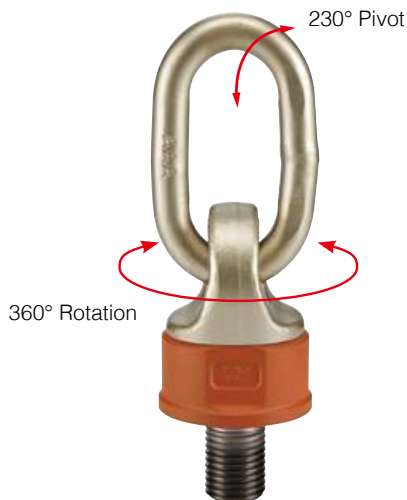
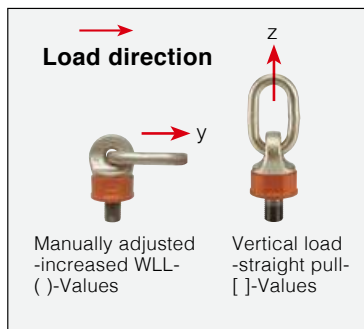
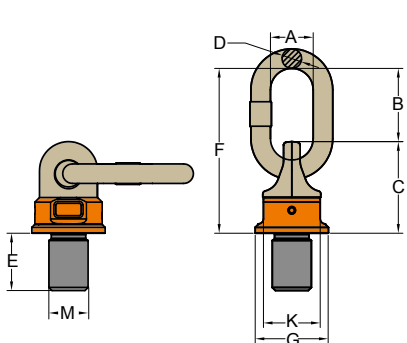

-40°C

- Pivots more than 230°, rotates through 360° due to its unique ball bearing design. Design factor 4:1 in all directions.
- Manufactured from forged alloy steel, quenched and tempered.
- Manufactured and tested in accordance with EN1677-1 and DNVGL-ST-0378.
- Load rated parts are 100% magnaflux crack detected.
- Individual forged parts and cap screw are traceable to Test Certification.
- Proof tested to 2.5 times the WLL.
- Fatigue rated to 1.5 times the WLL.
- All YOKE Lifting points meet or exceed all the requirements of ASME B30.26.
- Easy to attach or dismantle due to the forged hexagon shaped body of the DA Swivel Point.
- Maximum WLL in axial direction when load ring is aligned.
- Capable of rotating under load. Do not turn continuously in 90 degree direction at full load.

DA Swivel Point

UNC Thread (DA-272)

Item No.	Working Load Limit		Thread version			Dimensions (inch)						Torque in Nm	N.W. lbs	
	(y) tonnes	[z]	M inch	E inch	TPI	G	C	K	F inch	D	B			A
DA-272-006	0.7	1.2	1/2	0.75	13UNC	1.57	1.77	1.42	3.74	0.39	1.97	1.38	15 - 40	0.7
DA-272-013	1.5	2.6	5/8	0.94	11UNC	1.81	2.13	1.61	4.09	0.51	1.97	1.50	45 - 130	1.2
DA-272-018	2.0	3.6	3/4	1.13	10UNC	1.81	2.68	1.61	4.09	0.51	1.97	1.50	45 - 130	1.2
DA-272-020	2.5	4	7/8	1.31	9UNC	2.44	2.68	2.17	4.80	0.51	2.13	1.50	100 - 170	2.2
DA-272-035	4	7	1	1.50	8UNC	3.07	3.46	2.76	6.06	0.75	2.60	1.57	190 - 280	4.8
DA-272-060	6	10	1 1/4	1.88	7UNC	3.54	4.72	3.15	8.11	0.87	3.39	1.97	270 - 600	9.9
DA-272-080	10	15	1 1/2	2.25	6UNC	3.54	4.72	3.15	8.11	0.87	3.39	1.97	270 - 600	10
DA-272-120	13	17	1 3/4	2.63	5UNC	3.86	4.80	3.31	9.25	0.98	4.33	2.56	350 - 800	12.1
DA-272-130	16	18	2	3.00	4.5UNC	3.86	4.80	3.31	9.25	0.98	4.33	2.56	350 - 800	13.5
DA-272-140	20	25	2 1/4	3.38	4.5UNC	4.72	5.91	3.70	10.63	1.26	4.72	2.76	350 - 900	23.1
DA-272-160	22	28	2 1/2	3.75	4UNC	4.72	5.91	3.70	10.63	1.26	4.72	2.76	350 - 900	23.5

*Design factor 4:1 proof tested and certified.



-40°C

Kind of attachment																		
	Number of legs	1	2	1	2	2	2	2	2	2	3-4	3-4	3-4	3-4	3-4	3-4	3-4	3-4
Load direction	0°	0°	90°	90°	0-45°	45°- 60°	unsymm.	0 - 45°	45°- 60°	unsymm.								
Item No.	Thread	WLL(t)																
DA-272-006	1/2	1.2	2.4	0.7	1.5	0.8	0.6	0.6	1.2	0.9	0.6							
DA-272-013	5/8	2.6	5.2	1.5	3	1.8	1.3	1.3	2.7	1.9	1.3							
DA-272-018	3/4	3.6	7.2	2	4	2.5	1.8	1.8	3.7	2.7	1.8							
DA-272-020	7/8	4	8	2.5	5	2.8	2	2	4.2	3	2							
DA-272-035	1	7	14	4	8	4.9	3.5	3.5	7.3	5.2	3.5							
DA-272-060	1 1/4	10	20	6	12	7	5	5	10.5	7.5	5							
DA-272-080	1 1/2	15	30	10	20	14	10	10	21	15	10							
DA-272-120	1 3/4	17	34	13	26	18.2	13	13	27.3	19.5	13							
DA-272-130	2	18	36	14	28	19.6	14	14	29.4	21	14							
DA-272-140	2 1/4	25	50	20	40	28	20	20	42	30	20							
DA-272-160	2 1/2	28	56	20	40	28	20	20	42	30	20							

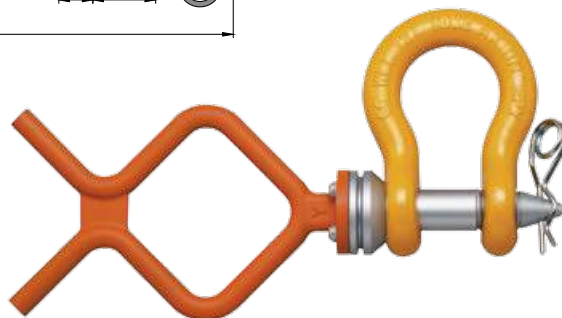
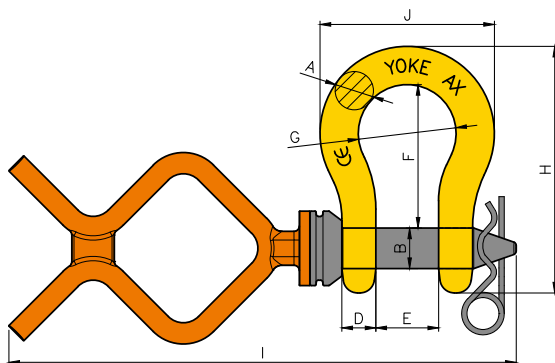

- Designed specifically for ROV application.
- Forged Steel, Quenched & Tempered, with alloy pins.
- Handles are Carbon Steel.
- Individually stamped with the safe working load.
- Shackle Bows are painted yellow to ensure ease of sight in water.
- Convertible handles on ROV shackle bolts

ROV Anchor Shackle

with Fishtail-handle and Safety Pin
(ROV: Remote Operate Vehicle)

Item No.	Nominal Size	Working Load Limit	Ultimate Breaking Force	Dimensions (inch)									N.W.
				A	B	C	D	E	G	H	I	J	
8-941-22	7/8	6.5	32.5	0.9	1.0	2.1	0.8	1.5	2.3	5.8	16.5	4.0	9.3
8-941-26	1	8.5	42.5	1.0	1.1	2.4	0.9	1.7	2.7	6.5	16.9	4.7	10.6
8-941-28	1-1/8	9.5	47.5	1.1	1.3	2.7	1.1	1.8	2.9	7.5	17.9	5.1	12.5
8-941-32	1-1/4	12.0	60.0	1.3	1.4	3.0	1.2	2.1	3.3	8.3	18.4	5.8	15.8
8-941-36	1-3/8	13.5	67.5	1.4	1.5	3.3	1.3	2.3	3.6	9.1	18.8	6.5	18.9
8-941-38	1-1/2	17.0	85.0	1.5	1.8	3.6	1.4	2.4	3.8	10.0	19.3	6.9	23.5
8-941-45	1-3/4	25.0	125.0	1.8	2.0	4.2	1.7	2.9	5.0	12.3	21.1	8.7	38.7
8-941-50	2	35.0	175.0	2.0	2.2	4.8	2.0	3.3	5.7	13.7	22.0	9.8	58.1

* Minimum Ultimate Load is 5 times the Working Load Limit.

Maximun Proof Load is 2 times the Working Load Limit.

Item No.	Nominal Size	Working Load Limit	Ultimate Breaking Force	Dimensions (mm)									N.W.
				A	B	C	D	E	G	H	I	J	
8-941-22	22	6.5	32.5	22	26	53	21.5	38	58	148	420	102	4.2
8-941-26	26	8.5	42.5	26	28	61	23	44	68	166	429	120	4.8
8-941-28	28	9.5	47.5	28	32	68	27	46	74	190	454	130	5.7
8-941-32	32	12.0	60.0	32	36	76	29.5	54	84	210	467	148	7.2
8-941-36	36	13.5	67.5	36	38	84	32	59	92	232	477	164	8.6
8-941-38	38	17.0	85.0	38	45	92	35	60.5	97	254	489	175	10.7
8-941-45	45	25.0	125.0	45	50	106	44	73	127	313	536	221	17.6
8-941-50	50	35.0	175.0	50	57	122	50.8	83.5	146	347.5	560	247.7	26.4

* Minimum Ultimate Load is 5 times the Working Load Limit.

Maximun Proof Load is 2 times the Working Load Limit.

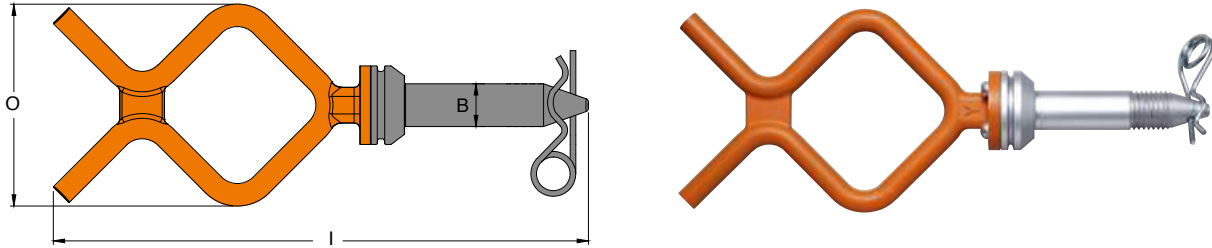

ROV Anchor Shackle Fishtail-handle

Item No.	Working Load Limit tonnes	Dimensions (inch)			N.W. lbs
		B	I	O	
8-941FT-22	6.5	1.02	16.54	7.09	5.9
8-941FT-26	8.5	1.10	16.89	7.09	6.4
8-941FT-28	9.5	1.26	17.87	7.09	7.0
8-941FT-32	12.0	1.42	18.39	7.09	7.7
8-941FT-36	13.5	1.50	18.78	7.09	8.4
8-941FT-38	17.0	1.77	19.25	7.09	9.7
8-941FT-45	25.0	1.97	21.10	7.09	12.3
8-941FT-50	35.0	2.24	22.05	7.09	15.2

Item No.	Working Load Limit tonnes	Dimensions (mm)			N.W. kg
		B	I	O	
8-941FT-22	6.5	26	420	180	2.7
8-941FT-26	8.5	28	429	180	2.9
8-941FT-28	9.5	32	454	180	3.2
8-941FT-32	12.0	36	467	180	3.5
8-941FT-36	13.5	38	477	180	3.8
8-941FT-38	17.0	45	489	180	4.4
8-941FT-45	25.0	50	536	180	5.6
8-941FT-50	35.0	57	560	180	6.9

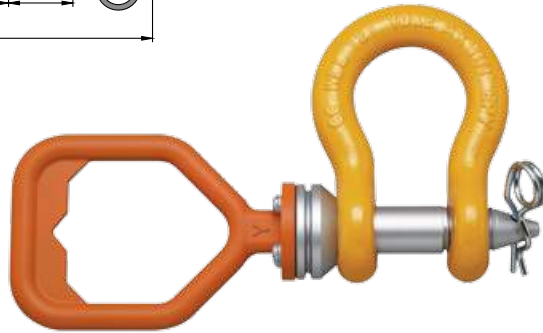
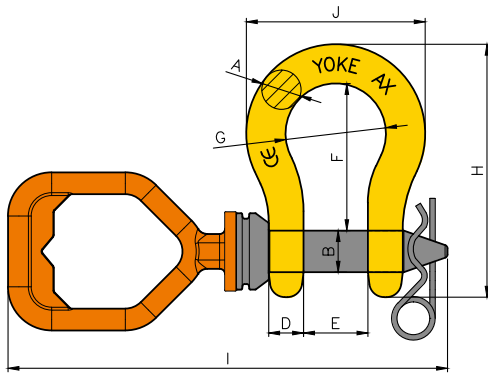

- Designed specifically for ROV application.
- Forged Steel, Quenched & Tempered, with alloy pins.
- Handles are Carbon Steel.
- Individually stamped with the safe working load.
- Shackle Bows are painted yellow to ensure ease of sight in water.
- Convertible handles on ROV shackle bolts

ROV Anchor Shackle

with D-handle and Safety Pin
(ROV: Remote Operate Vehicle)

Item No.	Nominal Size	Working Load Limit	Ultimate Breaking Force	Dimensions (inch)									N.W.
				A	B	C	D	E	G	H	I	J	
8-951-22	7/8	6.5	32.5	0.9	1.0	2.1	0.8	1.5	2.3	5.8	13.6	4.0	9.9
8-951-26	1	8.5	42.5	1.0	1.1	2.4	0.9	1.7	2.7	6.5	14.0	4.7	11.2
8-951-28	1-1/8	9.5	47.5	1.1	1.3	2.7	1.1	1.8	2.9	7.5	15.0	5.1	13.2
8-951-32	1-1/4	12.0	60.0	1.3	1.4	3.0	1.2	2.1	3.3	8.3	15.5	5.8	16.5
8-951-36	1-3/8	13.5	67.5	1.4	1.5	3.3	1.3	2.3	3.6	9.1	15.9	6.5	19.6
8-951-38	1-1/2	17.0	85.0	1.5	1.8	3.6	1.4	2.4	3.8	10.0	16.3	6.9	24.2
8-951-45	1-3/4	25.0	125.0	1.8	2.0	4.2	1.7	2.9	5.0	12.3	18.2	8.7	39.4
8-951-50	2	35.0	175.0	2.0	2.2	4.8	2.0	3.3	5.7	13.7	19.1	9.8	58.7

* Minimum Ultimate Load is 5 times the Working Load Limit.
Maximum Proof Load is 2 times the Working Load Limit.

Item No.	Nominal Size	Working Load Limit	Ultimate Breaking Force	Dimensions (mm)									N.W.
				A	B	C	D	E	G	H	I	J	
8-951-22	22	6.5	32.5	22	26	53	21.5	38	58	148	346	102	4.5
8-951-26	26	8.5	42.5	26	28	61	23	44	68	166	355	120	5.1
8-951-28	28	9.5	47.5	28	32	68	27	46	74	190	380	130	6.0
8-951-32	32	12.0	60.0	32	36	76	29.5	54	84	210	393	148	7.5
8-951-36	36	13.5	67.5	36	38	84	32	59	92	232	403	164	8.9
8-951-38	38	17.0	85.0	38	45	92	35	60.5	97	254	415	175	11.0
8-951-45	45	25.0	125.0	45	50	106	44	73	127	313	462	221	17.9
8-951-50	50	35.0	175.0	50	57	122	50.8	83.5	146	347.5	486	247.7	26.7

* Minimum Ultimate Load is 5 times the Working Load Limit.
Maximum Proof Load is 2 times the Working Load Limit.

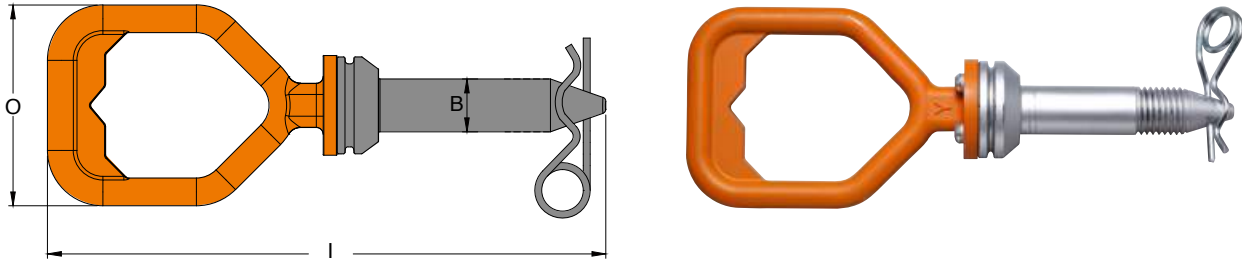

ROV Anchor Shackle D-handle

Item No.	Working Load Limit	Dimensions (inch)			N.W.
	tonnes	B	I	O	lbs
8-951DH-22	6.5	1.02	16.54	5.71	5.1
8-951DH-26	8.5	1.10	16.89	5.71	5.5
8-951DH-28	9.5	1.26	17.87	5.71	6.4
8-951DH-32	12.0	1.42	18.39	5.71	6.8
8-951DH-36	13.5	1.50	18.78	5.71	7.5
8-951DH-38	17.0	1.77	19.25	5.71	9.0
8-951DH-45	25.0	1.97	21.10	5.71	11.7
8-951DH-50	35.0	2.24	22.05	5.71	14.3

Item No.	Working Load Limit	Dimensions (mm)			N.W.
	tonnes	B	I	O	kg
8-951DH-22	6.5	26	420	145	2.3
8-951DH-26	8.5	28	429	145	2.5
8-951DH-28	9.5	32	454	145	2.9
8-951DH-32	12.0	36	467	145	3.1
8-951DH-36	13.5	38	477	145	3.4
8-951DH-38	17.0	45	489	145	4.1
8-951DH-45	25.0	50	536	145	5.3
8-951DH-50	35.0	57	560	145	6.5





ROV: Remote Operated Vehicle

- YOKE ROV shackles are designed specifically for ROV application.
- YOKE ROV shackles are manufactured with the highest quality steel available.
- YOKE ROV shackles are individually stamped with the safe working load.
- YOKE ROV shackles are painted white to ensure ease of sight in water.

ROV Anchor Shackle

with Safety Pin
(ROV: Remote Operated Vehicle)

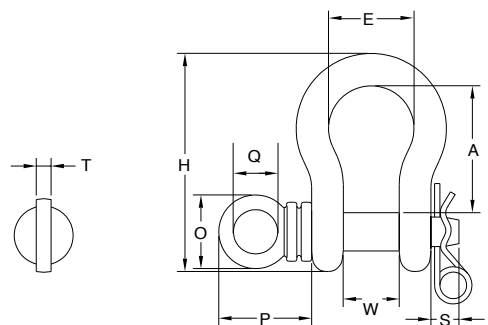

Item No.	Nominal Size		Working Load Limit tonnes*	Dimensions (inch)									N.W. lbs
	inch	mm		A	E	H	O	P	Q	S	T	W	
8-911-22	7/8	22	6.5	3.39	2.28	5.91	1.96	2.48	1.18	0.74	0.39	1.50	4.0
8-911-26	1	26	8.5	3.78	2.68	6.57	1.96	2.55	1.18	0.78	0.39	1.73	5.5
8-911-28	1 1/8	28	9.5	4.37	2.91	7.52	2.75	3.46	1.38	0.82	0.47	1.81	7.9
8-911-32	1 1/4	32	12.0	4.76	3.30	8.07	2.75	3.46	1.38	0.98	0.47	2.12	10.6
8-911-36	1 3/8	36	13.5	5.28	3.62	9.13	2.95	3.77	1.57	1.06	0.59	2.32	15.0
8-911-38	1 1/2	38	17.0	5.75	3.90	10.00	2.95	3.85	1.57	1.06	0.59	2.36	18.3
8-911-45	1 3/4	45	25.0	7.00	5.00	12.32	3.54	4.48	1.97	1.18	0.78	2.87	36.5
8-911-50	2	50	35.0	7.76	5.75	13.66	4.17	5.19	2.36	1.18	0.78	3.27	51.5

★ Minimum Ultimate Load is 5 times the Working Load Limit.
Maximun Proof Load is 2 times the Working Load Limit.

Item No.	Nominal Size		Working Load Limit tonnes*	Dimensions (mm)									N.W. kg
	inch	mm		A	E	H	O	P	Q	S	T	W	
8-911-22	7/8	22	6.5	86	58	148	50	63	30	19	10	38	1.8
8-911-26	1	26	8.5	96	69	166	50	65	30	20	10	44	2.5
8-911-28	1 1/8	28	9.5	111	74	190	70	88	35	21	12	46	3.6
8-911-32	1 1/4	32	12.0	121	84	210	70	88	35	25	12	54	4.8
8-911-36	1 3/8	36	13.5	134	92	232	75	96	40	27	15	59	6.8
8-911-38	1 1/2	38	17.0	146	99	254	75	98	40	27	15	60	8.3
8-911-45	1 3/4	45	25.0	178	127	313	90	114	50	30	20	73	16.6
8-911-50	2	50	35.0	197	146	347	106	132	60	30	20	83	23.4

★ Minimum Ultimate Load is 5 times the Working Load Limit.
Maximun Proof Load is 2 times the Working Load Limit.



ROV: Remote Operated Vehicle

- YOKE ROV hooks are designed specifically for ROV application.
- YOKE ROV hooks are manufactured with the highest quality steel available.
- YOKE ROV hooks are painted white to ensure ease of sight in water.

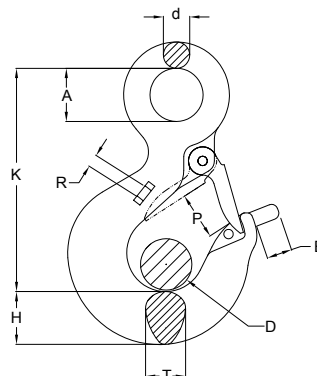

ROV Eye Sling Hook

(ROV: Remote Operated Vehicle)

Item No.	Working Load Limit	Dimensions (inch)									N.W.
	tonnes*	A	D	d	E	H	K	P	R	T	lbs
8-921-03	3.0	1.26	0.98	0.59	0.78	1.14	4.80	0.98	0.31	0.95	2.2
8-921-05	5.0	1.57	1.22	0.71	0.78	1.46	5.87	1.22	0.31	1.22	4.6
8-921-07	7.0	2.00	1.54	0.95	0.78	1.82	7.56	1.54	0.31	1.46	8.8
8-921-11	11.0	2.44	2.24	1.10	1.18	2.28	9.13	2.24	0.31	1.89	15.4
8-921-15	15.0	2.84	2.44	1.26	1.18	2.60	10.10	2.44	0.31	2.20	20.7
8-921-22	22.0	3.54	3.19	1.57	1.96	3.01	12.50	3.19	0.39	2.68	40.9
8-921-30	30.0	3.54	3.27	1.77	1.96	3.62	14.10	3.27	0.39	2.99	68.6

★ Minimum Ultimate Load is 4 times the Working Load Limit.
 Maximun Proof Load is 2 times the Working Load Limit.

Item No.	Working Load Limit	Dimensions (mm)									N.W.
	tonnes	A	D	d	E	H	K	P	R	T	kg
8-921-03	3.0	32	25	15	20	29	122	25	8	24	1.0
8-921-05	5.0	40	31	18	20	37	149	31	8	31	2.1
8-921-07	7.0	51	39	24	20	46	192	39	8	37	4.0
8-921-11	11.0	62	57	28	30	58	232	57	8	48	7.0
8-921-15	15.0	72	62	32	30	66	256	62	8	56	9.4
8-921-22	22.0	90	81	40	50	77	318	81	10	68	18.6
8-921-30	30.0	90	83	45	50	92	357	83	10	76	31.2

★ Minimum Ultimate Load is 4 times the Working Load Limit.
 Maximun Proof Load is 2 times the Working Load Limit.

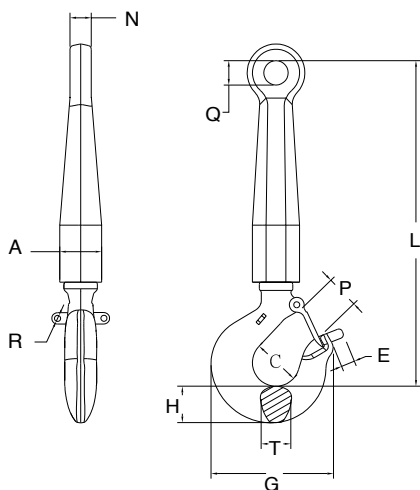

ROV: Remote Operated Vehicle

- YOKE ROV shank hooks are designed specifically for roV application.
- YOKE ROV shank hooks are manufactured with the highest quality steel available.
- YOKE ROV shank hooks are individually stamped with the safe working load.
- YOKE ROV shank hooks are painted white to ensure ease of sight in water.

ROV Shank Hook

(ROV: Remote Operated Vehicle)

Item No.	Working Load Limit tonnes*	Dimensions (inch)											N.W. lbs
		A	C	E	G	H	L	N	P	Q	R	T	
8-931-05	5.4	2.16	1.53	0.78	5.12	1.46	15.90	1.10	1.26	1.25	0.31	1.31	13.2
8-931-08	8.0	2.16	1.94	0.78	6.54	1.82	16.81	1.10	1.54	1.25	0.31	1.66	16.7
8-931-11	11.5	2.56	2.46	1.18	7.72	2.28	22.40	1.57	2.24	1.96	0.31	1.88	30.6
8-931-16	16.0	2.56	2.59	1.18	8.70	2.60	23.07	1.57	2.44	1.96	0.31	2.19	35.0
8-931-22	22.0	3.35	2.81	1.96	10.91	3.01	26.96	2.04	3.19	2.55	0.39	2.69	68.2
8-931-32	31.5	3.35	3.44	1.96	13.90	3.62	28.66	2.04	3.46	2.55	0.39	3.00	98.1























★ Minimum Ultimate Load is 4 times the Working Load Limit.
 Maximum Proof Load is 2 times the Working Load Limit.

Item No.	Working Load Limit tonnes*	Dimensions (mm)											N.W. kg
		A	C	E	G	H	L	N	P	Q	R	T	
8-931-05	5.4	55	38	20	130	37	404	28	32	32	8	33	6.0
8-931-08	8.0	55	49	20	166	46	427	28	39	32	8	42	7.6
8-931-11	11.5	65	62	30	196	58	569	40	57	50	8	48	13.9
8-931-16	16.0	65	65	30	221	66	586	40	62	50	8	56	15.9
8-931-22	22.0	85	71	50	277	77	685	52	81	65	10	68	31.0
8-931-32	31.5	85	87	50	353	92	728	52	88	65	10	76	44.6

★ Minimum Ultimate Load is 4 times the Working Load Limit.
 Maximum Proof Load is 2 times the Working Load Limit.



Quick index of YOKE Snatch Block & Trawl Block

Light Snatch Block					
	8-501 p.90		8-502 p.91		8-503 p.92
Forged Snatch Block					
	8-541 p.93		8-542 p.94		8-543 p.95
Super Snatch Block					
	8-551 p.96		8-552 p.97		8-553 p.98
Alloy Snatch Block					
	8-561 p.99		8-562 p.100		8-563 p.101
Alloy HC Snatch Block					
	8-571 p.102		8-572 p.103		8-573 p.104
Oilfield Block					
	8-591 p.105		8-591G p.105		
Hay Fork Pulley					
	8-512 p.108		8-514 p.109		8-515 p.110
Trawl Block					
	8-521 p.112		8-522 p.113		8-531 8-532



Superior Design Features of YOKE Snatch Blocks

- ✓ YSB sheaves are closed die drop forged steel. Available in size from 3" to 12" satisfying your heavy duty applications.
- ✓ Groove bottom hardened to 35 Rc maximizes durability of Snatch Blocks.

Quality approval by:







8-501-02
8-501-04



8-501-08 and up

- YOKE Light Snatch Blocks are manufactured of the highest quality tensile steel.
- Available from 2 tonnes to 8 tonnes, for wire rope sizes 8mm to 19mm.
- Part number, wire rope size and working load limit are marked on each block.
- Permanent batch codes link to test certificates for easy traceability.
- Supplied with bronze bushings and 4.5"-14" with pressure lube fittings.
- Meets or exceeds all requirements of ASME B30.26.
- Safety factor 4:1
- Fatigue rated



✓ Sheave by Closed Die Forged Steel

Light Snatch Block with Shackle

Item No.	Sheave Dia.	Bearing Type	Wire Rope Size	Working Load Limit	N.W.		Replacement Sheave
	inch		mm	t*	lbs	kg	
8-501-02	3	BB	8-10	2	4	2	8-500-02
8-501-04	4.5	BB	10-13	4	13	6	8-500-04
8-501-08	6	BB	16-19	8	29	13	8-500-08
8-501-0808	8	BB	16-19	8	44	20	8-500-0808
8-501-0810	10	BB	16-19	8	46	21	8-500-0810
** 8-501-0812-16	12	BB	16	8	49	22	8-500-0812-16
** 8-501-0812-19	12	BB	19	8	49	22	8-500-0812-19
** 8-501-0814-16	14	BB	16	8	56	25	8-500-0814-16
** 8-501-0814-19	14	BB	19	8	56	25	8-500-0814-19

*Minimum Ultimate Load is 4 times the Working Load Limit.

**Available from August, 2015



- YOKE Light Snatch Blocks are manufactured of the highest quality tensile steel.
- Available from 2 tonnes to 8 tonnes, for wire rope sizes 8mm to 19mm.
- Part number, wire rope size and working load limit are marked on each block.
- Permanent batch codes link to test certificates for easy traceability.
- Supplied with bronze bushings and 4.5"-14" with pressure lube fittings.
- Meets or exceeds all requirements of ASME B30.26.
- Safety factor 4:1
- Fatigue rated



✓ Sheave by Closed Die Forged Steel

Light Snatch Block with Hook

Item No.	Sheave Dia.	Bearing Type	Wire Rope Size	Working Load Limit	N.W.		Replacement Sheave
	inch		mm	t*	lbs	kg	
8-502-02	3	BB	8-10	2	7	3	8-500-02
8-502-04	4.5	BB	10-13	4	13	6	8-500-04
8-502-08	6	BB	16-19	8	29	13	8-500-08
8-502-0808	8	BB	16-19	8	42	19	8-500-0808
8-502-0810	10	BB	16-19	8	45	21	8-500-0810
8-502-0812-16	12	BB	16	8	48	22	8-500-0812-16
8-502-0812-19	12	BB	19	8	48	22	8-500-0812-19
** 8-502-0814-16	14	BB	16	8	55	25	8-500-0814-16
** 8-502-0814-19	14	BB	19	8	55	25	8-500-0814-19

*Minimum Ultimate Load is 4 times the Working Load Limit.

**Available from August, 2015



- YOKE Light Snatch Blocks are manufactured of the highest quality tensile steel.
- Available from 2 tonnes to 8 tonnes, for wire rope sizes 8mm to 19mm.
- Part number, wire rope size and working load limit are marked on each block.
- Permanent batch codes link to test certificates for easy traceability.
- Supplied with bronze bushings and 4.5"-14" with pressure lube fittings.
- Meets or exceeds all requirements of ASME B30.26.
- Safety factor 4:1
- Fatigue rated



✓ Sheave by Closed Die Forged Steel

Light Tail Board

Item No.	Sheave Dia.	Bearing Type	Wire Rope Size	Working Load Limit	N.W.		Replacement Sheave
	inch		mm	t*	lbs	kg	
8-503-02	3	BB	8-10	2	4	2	8-500-02
8-503-04	4.5	BB	10-13	4	8	4	8-500-04
8-503-08	6	BB	16-19	8	15	7	8-500-08
8-503-0808	8	BB	16-19	8	28	13	8-500-0808
8-503-0810	10	BB	16-19	8	29	13	8-500-0810
8-503-0812-16	12	BB	16	8	36	16	8-500-0812-16
8-503-0812-19	12	BB	19	8	36	16	8-500-0812-19
** 8-503-0814-16	14	BB	16	8	43	20	8-500-0814-16
** 8-503-0814-19	14	BB	19	8	43	20	8-500-0814-19

*Minimum Ultimate Load is 4 times the Working Load Limit.

**Available from August, 2015



- YOKE Forged Snatch Blocks are manufactured of the highest quality forged alloy steel.
- Available from 12 tonnes to 15 tonnes, for wire rope sizes 19mm to 22mm.
- Part number, wire rope size and working load limit are marked on each block.
- Permanent batch codes link to test certificates for easy traceability.
- Supplied with bronze bushings and pressure lube fittings.
- Meets or exceeds all requirements of ASME B30.26.
- Safety factor 4:1
- Fatigue rated



✓ Sheave by Closed Die Forged Steel

Forged Snatch Block with Shackle

Item No.	Sheave Dia.	Bearing Type	Wire Rope Size	Working Load Limit	N.W.		Replacement Sheave
	inch		mm	t*	lbs	kg	
8-541-12	6	BB	19-22	12	52	24	8-500-12
8-541-15	8	BB	19-22	15	61	28	8-500-15
8-541-1510	10	BB	19-22	15	90	41	8-500-1510

*Minimum Ultimate Load is 4 times the Working Load Limit.



- YOKE Forged Snatch Blocks are manufactured of the highest quality forged alloy steel.
- Available from 12 tonnes to 15 tonnes, for wire rope sizes 19mm to 22mm.
- Part number, wire rope size and working load limit are marked on each block.
- Permanent batch codes link to test certificates for easy traceability.
- Supplied with bronze bushings and pressure lube fittings.
- Meets or exceeds all requirements of ASME B30.26.
- Safety factor 4:1
- Fatigue rated



✓ Sheave by Closed Die Forged Steel

Forged Snatch Block with Hook

Item No.	Sheave Dia.	Bearing Type	Wire Rope Size	Working Load Limit	N.W.		Replacement Sheave
	inch				lbs	kg	
8-542-12	6	BB	19-22	12	48	22	8-500-12
8-542-15	8	BB	19-22	15	64	29	8-500-15
8-542-1510	10	BB	19-22	15	92	42	8-500-1510

*Minimum Ultimate Load is 4 times the Working Load Limit.



- YOKE Forged Snatch Blocks are manufactured of the highest quality forged alloy steel.
- Available from 12 tonnes to 15 tonnes, for wire rope sizes 19mm to 22mm.
- Part number, wire rope size and working load limit are marked on each block.
- Permanent batch codes link to test certificates for easy traceability.
- Supplied with bronze bushings and pressure lube fittings.
- Meets or exceeds all requirements of ASME B30.26.
- Safety factor 4:1
- Fatigue rated



✓ Sheave by Closed Die Forged Steel

Forged Tail Board

Item No.	Sheave Dia.	Bearing Type	Wire Rope Size	Working Load Limit	N.W.		Replacement Sheave
	inch		mm	t*	lbs	kg	
8-543-12	6	BB	19-22	12	29	14	8-500-12
8-543-15	8	BB	19-22	15	38	17	8-500-15
8-543-1510	10	BB	19-22	15	67	31	8-500-1510

*Minimum Ultimate Load is 4 times the Working Load Limit.



- YOKE Super Snatch Blocks are manufactured of the highest quality tensile steel.
- Available from 20 tonnes to 30 tonnes, for wire rope sizes 25mm to 32mm.
- Part number, wire rope size and working load limit are marked on each block.
- Permanent batch codes link to test certificates for easy traceability.
- Supplied with bronze bushings and pressure lube fittings.
- Meets or exceeds all requirements of ASME B30.26.
- Safety factor 4:1
- Fatigue rated



✓ Sheave by Closed Die Forged Steel

Super Snatch Block with Shackle

Item No.	Sheave Dia.	Bearing Type	Wire Rope Size	Working Load Limit	N.W.		Replacement Sheave
	inch				mm	t*	
8-551-20	8	BB	25-29	20	92	42	8-500-20
8-551-2010	10	BB	25-29	20	119	54	8-500-2010
8-551-2012-25	12	BB	25	20	139	63	8-500-2012-25
8-551-2012-29	12	BB	29	20	139	63	8-500-2012-29
8-551-2015-25	14	BB	25	20	150	68	8-500-2015-25
8-551-2015-29	14	BB	29	20	150	68	8-500-2015-29
** 8-551-2518-25	18	BB	25	25	260	118	8-500-2518-25
** 8-551-2518-29	18	BB	29	25	260	118	8-500-2518-29
** 8-551-3020-29	20	BB	29	30	398	181	8-500-3020-29
** 8-551-3020-32	20	BB	32	30	400	182	8-500-3020-32
** 8-551-3024-29	24	BB	29	30	475	216	8-500-3024-29
** 8-551-3024-32	24	BB	32	30	475	216	8-500-3024-32

* Minimum Ultimate Load is 4 times the Working Load Limit.

** Available from August, 2015



- YOKE Super Snatch Blocks are manufactured of the highest quality tensile steel.
- Available from 20 tonnes to 30 tonnes, for wire rope sizes 25mm to 32mm.
- Part number, wire rope size and working load limit are marked on each block.
- Permanent batch codes link to test certificates for easy traceability.
- Supplied with bronze bushings and pressure lube fittings.
- Meets or exceeds all requirements of ASME B30.26.
- Safety factor 4:1
- Fatigue rated



✓ Sheave by Closed Die Forged Steel

Super Snatch Block with Hook

Item No.	Sheave Dia.	Bearing Type	Wire Rope Size	Working Load Limit	N.W.		Replacement Sheave
	inch		mm	t*	lbs	kg	
8-552-20	8	BB	25-29	20	90	41	8-500-20
8-552-2010	10	BB	25-29	20	117	53	8-500-2010
8-552-2012-25	12	BB	25	20	139	63	8-500-2012-25
8-552-2012-29	12	BB	29	20	139	63	8-500-2012-29
8-552-2015-25	14	BB	25	20	154	70	8-500-2015-25
** 8-552-2015-29	14	BB	29	20	154	70	8-500-2015-29
** 8-552-2518-25	18	BB	25	25	240	109	8-500-2518-25
** 8-552-2518-29	18	BB	29	25	240	109	8-500-2518-29
** 8-552-3020-29	20	BB	29	30	375	171	8-500-3020-29
** 8-552-3020-32	20	BB	32	30	375	171	8-500-3020-32
** 8-552-3024-29	24	BB	29	30	450	205	8-500-3024-29
** 8-552-3024-32	24	BB	32	30	450	205	8-500-3024-32

* Minimum Ultimate Load is 4 times the Working Load Limit.

** Available from August, 2015



- YOKE Super Snatch Blocks are manufactured of the highest quality tensile steel.
- Available from 20 tonnes to 30 tonnes, for wire rope sizes 25mm to 32mm.
- Part number, wire rope size and working load limit are marked on each block.
- Permanent batch codes link to test certificates for easy traceability.
- Supplied with bronze bushings and pressure lube fittings.
- Meets or exceeds all requirements of ASME B30.26.
- Safety factor 4:1
- Fatigue rated



✓ Sheave by Closed Die Forged Steel

Super Tail Board

Item No.	Sheave Dia.	Bearing Type	Wire Rope Size	Working Load Limit	N.W.		Replacement Sheave
	inch		mm	t*	lbs	kg	
8-553-20	8	BB	25-29	20	51	23	8-500-20
8-553-2010	10	BB	25-29	20	77	35	8-500-2010
8-553-2012-25	12	BB	25	20	99	45	8-500-2012-25
8-553-2012-29	12	BB	29	20	99	45	8-500-2012-29
8-553-2015-25	14	BB	25	20	112	51	8-500-2015-25
** 8-553-2015-29	14	BB	29	20	112	51	8-500-2015-29
** 8-553-2518-25	18	BB	25	25	165	75	8-500-2518-25
** 8-553-2518-29	18	BB	29	25	165	75	8-500-2518-29
** 8-553-3020-29	20	BB	29	30	215	98	8-500-3020-29
** 8-553-3020-32	20	BB	32	30	215	98	8-500-3020-32
** 8-553-3024-29	24	BB	29	30	290	132	8-500-3024-29
** 8-553-3024-32	24	BB	32	30	290	132	8-500-3024-32

* Minimum Ultimate Load is 4 times the Working Load Limit.

** Available from August, 2015



- YOKE Alloy Snatch Blocks are manufactured of the highest quality alloy steel.
- Available in 12 tonnes, for wire rope sizes 19mm to 22mm.
- Part number, wire rope size and working load limit are marked on each block.
- Permanent batch codes link to test certificates for easy traceability.
- Supplied with bronze bushings and pressure lube fittings.
- Meets or exceeds all requirements of ASME B30.26.
- Safety factor 4:1
- Fatigue rated



✓ Sheave by Closed Die Forged Steel

Alloy Snatch Block with Shackle

Item No.	Sheave Dia.	Bearing Type	Wire Rope Size	Working Load Limit	N.W.		Replacement Sheave
	inch				mm	t*	
8-561-12	6	BB	19-22	12	28	13	8-500-12
8-561-1208	8	BB	19-22	12	37	17	8-500-1208
8-561-1210	10	BB	19-22	12	46	21	8-500-1210

*Minimum Ultimate Load is 4 times the Working Load Limit.



- YOKE Alloy Snatch Blocks are manufactured of the highest quality alloy steel.
- Available in 12 tonnes, for wire rope sizes 19mm to 22mm.
- Part number, wire rope size and working load limit are marked on each block.
- Permanent batch codes link to test certificates for easy traceability.
- Supplied with bronze bushings and pressure lube fittings.
- Meets or exceeds all requirements of ASME B30.26.
- Safety factor 4:1
- Fatigue rated



✓ Sheave by Closed Die Forged Steel

Alloy Snatch Block with Hook

Item No.	Sheave Dia.	Bearing Type	Wire Rope Size	Working Load Limit	N.W.		Replacement Sheave
	inch				lbs	kg	
8-562-12	6	BB	19-22	12	31	14	8-500-12
8-562-1208	8	BB	19-22	12	37	17	8-500-1208
8-562-1210	10	BB	19-22	12	46	21	8-500-1210

*Minimum Ultimate Load is 4 times the Working Load Limit.



- Yoke Alloy Snatch Blocks are manufactured of the highest quality alloy steel.
- Available in 12 tonnes, for wire rope sizes 19mm to 22mm.
- Part number, wire rope size and working load limit are marked on each block.
- Permanent batch codes link to test certificates for easy traceability.
- Supplied with bronze bushings and pressure lube fittings.
- Meets or exceeds all requirements of ASME B30.26.
- Safety factor 4:1
- Fatigue rated



✓ Sheave by Closed Die Forged Steel

Alloy Tail Board

Item No.	Sheave Dia.	Bearing Type	Wire Rope Size	Working Load Limit	N.W.		Replacement Sheave
	inch		mm	t*	lbs	kg	
8-563-12	6	BB	19-22	12	15	7	8-500-12
8-563-1208	8	BB	19-22	12	22	10	8-500-1208
8-563-1210	10	BB	19-22	12	33	15	8-500-1210

*Minimum Ultimate Load is 4 times the Working Load Limit.



- YOKE Alloy HC Snatch Blocks are manufactured of the highest quality alloy steel.
- Available from 25 tonnes to 30 tonnes, for wire rope sizes 25mm to 32mm.
- Part number, wire rope size and working load limit are marked on each block.
- Permanent batch codes link to test certificates for easy traceability.
- Supplied with bronze bushings and pressure lube fittings.
- Meets or exceeds all requirements of ASME B30.26.
- Safety factor 4:1
- Fatigue rated



✓ Sheave by Closed Die Forged Steel

Alloy HC Snatch Block with Shackle

Item No.	Sheave Dia.	Bearing Type	Wire Rope Size	Working Load Limit	N.W.		Replacement Sheave
	inch				mm	t*	
8-571-2508-25	8	BB	25	25	90	41	8-500-2508-25
8-571-2508-29	8	BB	29	25	90	41	8-500-2508-29
8-571-2510-25	10	BB	25	25	107	49	8-500-2510-25
8-571-2510-29	10	BB	29	25	107	49	8-500-2510-29
8-571-2510-32	10	BB	32	25	107	49	8-500-2510-32
8-571-3012-25	12	BB	25	30	165	75	8-500-3012-25
8-571-3012-29	12	BB	29	30	165	75	8-500-3012-29
** 8-571-3014-25	14	BB	25	30	180	82	8-500-3014-25
** 8-571-3014-29	14	BB	29	30	180	82	8-500-3014-29

* Minimum Ultimate Load is 4 times the Working Load Limit.

** Available from August, 2015



- YOKE Alloy HC Snatch Blocks are manufactured of the highest quality alloy steel.
- Available from 25 tonnes to 30 tonnes, for wire rope sizes 25mm to 32mm.
- Part number, wire rope size and working load limit are marked on each block.
- Permanent batch codes link to test certificates for easy traceability.
- Supplied with bronze bushings and pressure lube fittings.
- Meets or exceeds all requirements of ASME B30.26.
- Safety factor 4:1
- Fatigue rated



✓ Sheave by Closed Die Forged Steel

Alloy HC Snatch Block with Hook

Item No.	Sheave Dia.	Bearing Type	Wire Rope Size	Working Load Limit	N.W.		Replacement Sheave
	inch		mm	t*	lbs	kg	
8-572-2508-25	8	BB	25	25	90	41	8-500-2508-25
8-572-2508-29	8	BB	29	25	90	41	8-500-2508-29
8-572-2510-25	10	BB	25	25	107	49	8-500-2510-25
8-572-2510-29	10	BB	29	25	107	49	8-500-2510-29
8-572-2510-32	10	BB	32	25	107	49	8-500-2510-32
8-572-3012-25	12	BB	25	30	165	75	8-500-3012-25
8-572-3012-29	12	BB	29	30	165	75	8-500-3012-29
** 8-572-3014-25	14	BB	25	30	180	82	8-500-3014-25
** 8-572-3014-29	14	BB	29	30	180	82	8-500-3014-29

* Minimum Ultimate Load is 4 times the Working Load Limit.

** Available from August, 2015



- YOKE Alloy HC Snatch Blocks are manufactured of the highest quality alloy steel.
- Available from 25 tonnes to 30 tonnes, for wire rope sizes 25mm to 32mm.
- Part number, wire rope size and working load limit are marked on each block.
- Permanent batch codes link to test certificates for easy traceability.
- Supplied with bronze bushings and pressure lube fittings.
- Meets or exceeds all requirements of ASME B30.26.
- Safety factor 4:1
- Fatigue rated



✓ Sheave by Closed Die Forged Steel

Alloy HC Tail Board

Item No.	Sheave Dia.	Bearing Type	Wire Rope Size	Working Load Limit	N.W.		Replacement Sheave
	inch				mm	t*	
8-573-2508-25	8	BB	25	25	50	23	8-500-2508-25
8-573-2508-29	8	BB	29	25	50	23	8-500-2508-29
8-573-2510-25	10	BB	25	25	65	30	8-500-2510-25
8-573-2510-29	10	BB	29	25	65	30	8-500-2510-29
8-573-2510-32	10	BB	32	25	65	30	8-500-2510-32
8-573-3012-25	12	BB	25	30	95	43	8-500-3012-25
8-573-3012-29	12	BB	29	30	95	43	8-500-3012-29
** 8-573-3014-25	14	BB	25	30	110	50	8-500-3014-25
** 8-573-3014-29	14	BB	29	30	110	50	8-500-3014-29

*Minimum Ultimate Load is 4 times the Working Load Limit.

**Available from August, 2015



- YOKE Oilfield Hoist Blocks are manufactured of the highest quality alloy steel.
- Available from 4 tonnes to 30 tonnes for wire rope sizes 8mm to 20mm.
- Part number, wire rope size and working load limit are marked on each block.
- Permanent batch codes link to test certificates for easy traceability.
- Supplied with sealed tapered bearings for extended product life and faster line speeds.
- Safety factor 4:1
- Manufactured by an API Q1 Certified facility.

Galvanized

Oilfield Hoist Block

Item No.	Item No.	Sheave Dia.	Bearing Type	Wire Rope Size	Working Load Limit	N.W.	
		inch		mm	t*	lbs	kg
8-591-0408	8-591-0408G	8	TB	10-13	4	35	16
8-591-0810-13	8-591-0810-13G	10	TB	10-13	8	55	25
8-591-0810-15	8-591-0810-15G	10	TB	13-15	8	55	25
8-591-1210-15	8-591-1210-15G	10	TB	13-15	12	55	25
8-591-1214-16	8-591-1214-16G	14	TB	16	12	95	43
8-591-1214-19	8-591-1214-19G	14	TB	19	12	95	43
8-591-1516-22	8-591-1516-22G	16	TB	22	15	150	68
8-591-1516-26	8-591-1516-26G	16	TB	26	15	150	68
8-591-2518	8-591-2518G	18	TB	29	25	260	118
8-591-3020	8-591-3020G	20	TB	32	30	675	307

*Minimum Ultimate Load is 4 times the Working Load Limit.

TB=Tapered Bearing



- YOKE Sheaves are manufactured of the highest quality tensile steel.
- Available for wire rope sizes 8mm to 32mm.
- Permanent batch codes link to test certificates for easy traceability.

Sheaves for Snatch Block

Bronze Bushing

Item No.	Sheave Dia.	Bearing type	Wire Rope Size	N.W.	
	inch		mm	lbs	Kg
8-500-02	3	BB	8-10	2	1
8-500-04	4.5	BB	10-13	4	2
8-500-08	6	BB	16-19	6	3
8-500-0808	8	BB	16-19	10	5
8-500-0810	10	BB	16-19	15	7
8-500-0812-16	12	BB	16	17	8
8-500-0812-19	12	BB	19	17	8
8-500-0814-16	14	BB	16	19	9
** 8-500-0814-19	14	BB	19	19	9
** 8-500-12	6	BB	19-22	10	5
8-500-1208	8	BB	19-22	14	6
8-500-1210	10	BB	19-22	36	16
8-500-15	8	BB	19-22	16	7
8-500-1510	10	BB	19-22	27	12
8-500-20	8	BB	25-29	16	7
8-500-2010	10	BB	25-29	24	11
8-500-2012-25	12	BB	25	34	15
8-500-2012-29	12	BB	29	34	15
** 8-500-2015-25	14	BB	25	36	16
** 8-500-2015-29	14	BB	29	36	16
8-500-2508-25	8	BB	25	30	14
8-500-2508-29	8	BB	29	30	14
8-500-2510-25	10	BB	25	36	16
8-500-2510-29	10	BB	29	36	16
** 8-500-2510-32	10	BB	32	36	16
** 8-500-2518-25	18	BB	25	40	18
** 8-500-2518-29	18	BB	29	40	18
8-500-3012-25	12	BB	25	28	13
** 8-500-3012-29	12	BB	29	28	13
** 8-500-3014-25	14	BB	25	32	15
** 8-500-3014-29	14	BB	29	32	15
** 8-500-3020-29	20	BB	29	44	20
** 8-500-3020-32	20	BB	32	44	20
** 8-500-3024-29	24	BB	29	48	22
8-500-3024-32	24	BB	32	48	22

**Available from August, 2015



- YOKE Snatch Blocks are manufactured of the highest quality tensile steel.
- Part number, wire rope size and working load limit are marked on each block.
- Permanent batch codes link to test certificates for easy traceability.
- Supplied with bronze bushings and pressure lube fittings.
- Meets or exceeds all requirements of ASME B30.26.
- Safety factor 4:1
- Fatigue rated



✓ Sheave by Closed Die Forged Steel

Snatch Block with Swivel Eye

Item No.	Sheave Dia.	Bearing Type	Wire Rope Size	Working Load Limit	N.W.		Replacement Sheave
	inch		mm	t*	lbs	kg	
8-504-02	3	BB	8-10	2	5	2	8-500-02

*Minimum Ultimate Load is 4 times the Working Load Limit.

- YOKE Hay Fork Pulley features one piece pressed steel shell and forged hook.
- Rounded edges to prevent rope damages.
- Supplied with bronze bushings and pressure lube fittings.
- Manila rope and wire line applications



Hay Fork Pulley with Swivel Hook

Item No.	Working Load Limit	Sheave Dia.	Rope Code	Rope Size	N.W.	
	t*	inch		mm	lbs	kg
8-512-01MR	1	4.5	Manila Rope	32	9	4
8-512-01WL	1	4.5	Wire Line	10 - 13	9	4
8-512-02MR	2	6	Manila Rope	38	15	7
8-512-02WL	2	6	Wire Line	16	15	7

★ Minimum Ultimate Load is 4 times the Working Load Limit.



- YOKE Hay Fork Pulley features one piece pressed steel shell and forged hook.
- Rounded edges to prevent rope damages.
- Supplied with bronze bushings and pressure lube fittings.
- Manila rope and wire line applications

Hay Fork Pulley with Swivel Eye

Item No.	Working Load Limit	Sheave Dia.	Rope Code	Rope Size	N.W.	
	t*			inch	mm	lbs
8-514-01MR	1	4.5	Manila Rope	32	7	3
8-514-01WL	1	4.5	Wire Line	10 - 13	7	3
8-514-02MR	2	6	Manila Rope	38	13	6
8-514-02WL	2	6	Wire Line	16	13	6

★ Minimum Ultimate Load is 4 times the Working Load Limit.



- YOKE Hay Fork Pulley features one piece pressed steel shell and forged hook.
- Rounded edges to prevent rope damages.
- Supplied with bronze bushings and pressure lube fittings.
- Manila rope and wire line applications

Hay Fork Pulley with Swivel Eye

Item No.	Working Load Limit	Sheave Dia.	Rope Code	Rope Size	N.W.	
	t*	inch		mm	lbs	kg
8-515-02WL	2	8	Wire Line	13	13	6

★ Minimum Ultimate Load is 4 times the Working Load Limit.





- All parts are forged: swivel eye, side plates and sheave.
- Hot dipped galvanized finish provides corrosive resistance in salt water environment.
- Supplied with needle bearings and pressure lube fittings.
- Individually tested for maximum safety.

Trawl Block

with Swivel Eye

Item No.	Sheave Dimensions (inch)		Bearing Type	Working Load Limit	N.W.	
	inch	Rim Thickness			t*	lbs
8-521-05	6	2 3/4	Needle bearing	5	27	12

★ Minimum Ultimate Load is 4 times the Working Load Limit.



- All parts are forged: swivel eye, side plates and sheave.
- Hot dipped galvanized finish provides corrosive resistance in salt water environment.
- Supplied with tapered bearings and pressure lube fittings.
- Individually tested for maximum safety.

Trawl Block

with Swivel Eye

Item No.	Sheave Dimensions (inch)		Bearing Type	Working Load Limit	N.W.	
	inch	Rim Thickness			t*	lbs
8-523-10	8	2 7/8	Tapered bearing	10	44	20

★ Minimum Ultimate Load is 4 times the Working Load Limit.



- Forged swivel eye and sheave, pressed side plates with extra throat opening allowing nets and fittings to pass through.
- Hot dipped galvanized finish provides corrosive resistance in salt water environment.
- Supplied with bronze bushing and pressure lube fittings.
- Individually tested for maximum safety.

Trawl Block

with Swivel Eye

Item No.	Sheave Dimensions (inch)		Bearing Type	Working Load Limit	N.W.	
	inch	Rim Thickness			lbs	kg
8-522-05	6	2 3/4	Bronze bushed	5	32	15

★ Minimum Ultimate Load is 4 times the Working Load Limit.



- Corrosive resistant in salt water environment.
- Supplied with tapered bearings with pressure lube fittings.
- Individually tested for maximum safety.

Lobster Block

with Swivel Hook

Item No.	Sheave Dimensions (mm)		Bearing Type	Working Load Limit	N.W.	
	mm	Rim Thickness			t*	lbs
8-531-01	114	70	Tapered bearing	1	13	6

★ Minimum Ultimate Load is 4 times the Working Load Limit.



- Corrosive resistant in salt water environment.
- Supplied with tapered bearings with pressure lube fittings.
- Individually tested for maximum safety.

Lobster Block

with Swivel Eye

Item No.	Sheave Dimensions (mm)		Bearing Type	Working Load Limit	N.W.	
	mm	Rim Thickness			t*	lbs
8-532-01	114	70	Tapered bearing	1	13	6

★ Minimum Ultimate Load is 4 times the Working Load Limit.



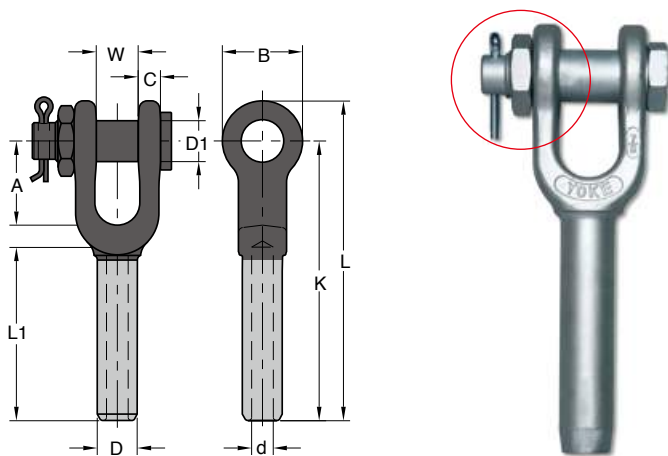

- YOKE 8-730 Opened Swage Sockets are forged from special bar quality carbon steel with very finest hardness controlled by spheroidize annealing.
- YOKE Swage Sockets properly applied have an efficiency rating of 100% based on the catalog strength of wire rope.
- YOKE Swage Sockets are recommended for use with 6x19, 6x37, and IWRC wire rope. They are approved for use with galvanized bridge rope.
- YOKE Swage Sockets are not recommended for use on fiber core or lang lay rope.

All slings swaged with sockets shall be proof loaded in accordance with ASME B30.9

Forged Open Swage Wire Rope Socket

with Safety Bolt Pin

Item No.		Rope Size	Before Swage Dimensions (inch)										Max. After Swage Dim.	N.W.
S.C.*	Galvanized	inch	A	B	C	D	D1	d	K	L	L1	W	inch	lbs
8-730-06	8-730-06G	1/4	1.50	1.38	0.35	0.50	0.67	0.27	4.02	4.80	2.17	0.67	0.46	0.7
8-730-08	8-730-08G	5/16	1.77	1.65	0.47	0.77	0.79	0.34	5.31	6.26	3.15	0.79	0.71	1.3
8-730-10	8-730-10G	3/8	1.77	1.65	0.47	0.77	0.79	0.41	5.31	6.26	3.15	0.79	0.71	1.5
8-730-11	8-730-11G	7/16	1.96	2.00	0.55	0.98	0.98	0.48	6.85	7.83	4.33	1.00	0.91	2.4
8-730-13	8-730-13G	1/2	1.96	2.00	0.55	0.98	1.19	0.55	6.85	7.83	4.33	1.00	0.91	2.4
8-730-14	8-730-14G	9/16	2.25	2.36	0.68	1.25	1.19	0.62	8.27	9.45	5.31	1.22	1.16	5.3
8-730-16	8-730-16G	5/8	2.25	2.36	0.68	1.25	1.19	0.67	8.27	9.45	5.31	1.22	1.16	5.1
8-730-19	8-730-19G	3/4	2.75	2.75	0.79	1.55	1.38	0.82	10.07	11.61	6.34	1.50	1.42	8.8
8-730-22	8-730-22G	7/8	3.23	3.15	0.94	1.70	1.63	0.94	11.81	13.39	7.44	1.77	1.55	13.0
8-730-26	8-730-26G	1	3.86	3.94	1.02	1.98	2.00	1.06	13.58	15.55	8.50	2.00	1.80	20.2
8-730-28	8-730-28G	1 1/8	4.26	4.06	1.19	2.25	2.20	1.19	15.08	17.40	9.37	2.25	2.05	28.2
8-730-32	8-730-32G	1 1/4	4.72	4.45	1.34	2.53	2.48	1.33	16.50	19.06	10.59	2.48	2.30	39.2
8-730-36	8-730-36G	1 3/8	5.20	5.00	1.38	2.80	2.44	1.45	18.23	21.02	11.69	2.52	2.56	48.0
8-730-38	8-730-38G	1 1/2	5.75	5.51	1.69	3.08	2.52	1.61	19.75	22.88	12.40	3.00	2.81	63.6
8-730-45	8-730-45G	1 3/4	6.75	6.70	2.11	3.39	3.50	1.86	23.00	26.53	14.88	3.50	3.06	96.8
8-730-50	8-730-50G	2	8.00	8.00	2.37	3.94	3.75	2.11	26.88	31.44	16.96	4.00	3.56	160.8

★ S.C. = Self Colored.

Item No.		Rope Size	Before Swage Dimensions (mm)										Max. After Swage Dim.	N.W.
S.C.*	Galvanized	mm	A	B	C	D	D1	d	K	L	L1	W	mm	kg
8-730-06	8-730-06G	6- 7	38	35	9	13	18	7	102	122	55	17	12	0.3
8-730-08	8-730-08G	8	45	42	12	20	21	9	135	159	80	20	18	0.6
8-730-10	8-730-10G	9-10	45	42	12	20	21	10	135	159	80	20	18	0.7
8-730-11	8-730-11G	11-12	50	50	14	25	25	12	174	199	110	25	23	1.1
8-730-13	8-730-13G	13	50	50	14	25	25	14	174	199	110	25	23	1.1
8-730-14	8-730-14G	14-15	57	60	17	32	30	16	210	240	135	31	30	2.4
8-730-16	8-730-16G	16	57	60	17	32	30	17	210	240	135	31	30	2.3
8-730-19	8-730-19G	18-20	70	70	20	39	35	21	256	295	161	38	36	4.0
8-730-22	8-730-22G	22-23	82	80	24	43	41	24	300	340	189	45	40	5.9
8-730-26	8-730-26G	24-25	98	100	26	50	51	27	345	395	216	50	46	9.1
8-730-28	8-730-28G	28	108	103	30	57	57	30	383	442	238	57	52	12.8
8-730-32	8-730-32G	32	120	113	34	64	64	34	419	484	269	63	59	17.8
8-730-36	8-730-36G	35-36	132	127	35	71	64	37	463	534	297	64	65	21.8
8-730-38	8-730-38G	38	146	140	43	78	70	41	502	581	315	76	72	28.9
8-730-45	8-730-45G	44-45	171	170	54	86	89	47	584	674	378	89	78	44.0
8-730-50	8-730-50G	48-51	203	203	60	100	95	54	682	798	431	101	91	73.1

★ S.C. = Self Colored.

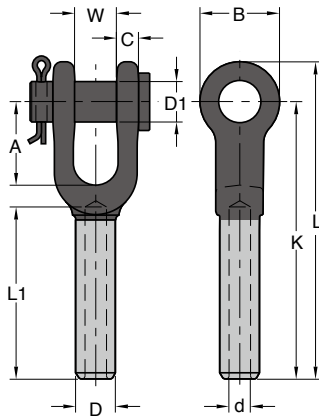

- YOKE 8-731 Opened Swage Sockets are forged from special bar quality carbon steel with very finest hardness controlled by spheroidize annealing.
- YOKE Swage Sockets properly applied have an efficiency rating of 100% based on the catalog strength of wire rope.
- YOKE Swage Sockets are recommended for use with 6x19, 6x37, and IWRC wire rope. They are approved for use with galvanized bridge rope.
- YOKE Swage Sockets are not recommended for use on fiber core or lang lay rope.

All slings swaged with sockets shall be proof loaded in accordance with ASME B30.9

Forged Open Swage Socket

with Round Pin

Item No.		Rope Size	Before Swage Dimensions (inch)										Max. After Swage Dim.	N.W.
S.C.*	Galvanized	inch	A	B	C	D	D1	d	K	L	L1	W	inch	lbs
8-731-06	8-731-06G	1/4	1.50	1.38	0.35	0.50	0.69	0.27	4.02	4.80	2.17	0.67	0.46	0.7
8-731-08	8-731-08G	5/16	1.77	1.65	0.47	0.77	0.81	0.34	5.31	6.26	3.15	0.79	0.71	1.5
8-731-10	8-731-10G	3/8	1.77	1.65	0.47	0.77	0.81	0.41	5.31	6.26	3.15	0.79	0.71	1.3
8-731-11	8-731-11G	7/16	1.96	2.00	0.55	0.98	1.00	0.48	6.85	7.83	4.33	1.00	0.91	2.6
8-731-13	8-731-13G	1/2	1.96	2.00	0.55	0.98	1.00	0.55	6.85	7.83	4.33	1.00	0.91	2.4
8-731-14	8-731-14G	9/16	2.25	2.36	0.68	1.25	1.19	0.62	8.27	9.45	5.31	1.22	1.16	4.6
8-731-16	8-731-16G	5/8	2.25	2.36	0.68	1.25	1.19	0.67	8.27	9.45	5.31	1.22	1.16	4.6
8-731-19	8-731-19G	3/4	2.75	2.75	0.79	1.55	1.38	0.82	10.07	11.61	6.34	1.50	1.42	8.4
8-731-22	8-731-22G	7/8	3.23	3.15	0.94	1.70	1.63	0.94	11.81	13.39	7.44	1.77	1.55	11.9
8-731-26	8-731-26G	1	3.86	3.94	1.02	1.98	2.00	1.06	13.58	15.55	8.50	2.00	1.80	17.8
8-731-28	8-731-28G	1 1/8	4.26	4.06	1.19	2.25	2.20	1.19	15.08	17.40	9.37	2.25	2.05	27.5
8-731-32	8-731-32G	1 1/4	4.72	4.45	1.34	2.53	2.25	1.33	16.50	19.06	10.59	2.48	2.30	38.5
8-731-36	8-731-36G	1 3/8	5.20	5.00	1.38	2.80	2.50	1.45	18.23	21.02	11.69	2.52	2.56	46
8-731-38	8-731-38G	1 1/2	5.75	5.51	1.69	3.08	2.52	1.61	19.75	22.88	12.40	3.00	2.81	66
8-731-45	8-731-45G	1 3/4	6.75	6.70	2.11	3.39	3.50	1.86	23.00	26.53	14.88	3.50	3.06	88.7
8-731-50	8-731-50G	2	8.00	8.00	2.37	3.94	3.75	2.11	26.88	31.44	16.96	4.00	3.56	146.1

★ S.C. = Self Colored.

Item No.		Rope Size	Before Swage Dimensions (mm)										Max. After Swage Dim.	N.W.
S.C.*	Galvanized	mm	A	B	C	D	D1	d	K	L	L1	W	mm	kg
8-731-06	8-731-06G	6- 7	38	35	9	13	18	7	102	122	55	17	12	0.3
8-731-08	8-731-08G	8	45	42	12	20	21	9	135	159	80	20	18	0.7
8-731-10	8-731-10G	9-10	45	42	12	20	21	10	135	159	80	20	18	0.6
8-731-11	8-731-11G	11-12	50	50	14	25	25	12	174	199	110	25	23	1.2
8-731-13	8-731-13G	13	50	50	14	25	25	14	174	199	110	25	23	1.1
8-731-14	8-731-14G	14-15	70	60	17	32	30	16	210	240	135	31	30	2.1
8-731-16	8-731-16G	16	57	60	17	32	30	17	210	240	135	31	30	2.1
8-731-19	8-731-19G	18-20	70	70	20	39	35	21	256	295	161	38	36	3.8
8-731-22	8-731-22G	22-23	82	80	24	43	41	24	300	340	189	45	40	5.4
8-731-26	8-731-26G	24-25	98	100	26	50	51	27	345	395	216	50	46	8.1
8-731-28	8-731-28G	28	108	103	30	57	57	30	383	442	238	57	52	12.5
8-731-32	8-731-32G	32	120	113	34	64	64	34	419	484	269	63	59	17.5
8-731-36	8-731-36G	35-36	132	127	35	71	64	37	463	534	297	64	65	20.9
8-731-38	8-731-38G	38	146	140	43	78	70	41	502	581	315	76	72	30.0
8-731-45	8-731-45G	44-45	171	170	54	86	89	47	584	674	378	89	78	40.3
8-731-50	8-731-50G	48-51	203	203	60	100	95	54	682	798	431	101	91	66.4

★ S.C. = Self Colored.

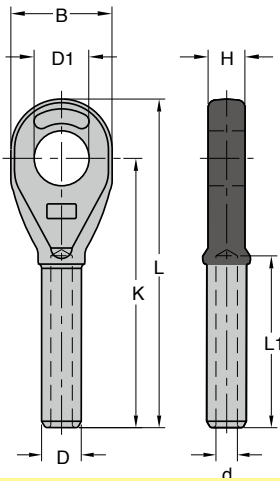

- YOKE 8-732 Closed Swage are forged from special bar quality carbon steel with very finest hardness controlled by spheroidize annealing.
- YOKE Swage properly applied have an efficiency rating of 100% based on the catalog strength of wire rope.
- YOKE Swage are recommended for use with 6x19, 6x36, and IWRC wire rope. They are approved for use with galvanized bridge rope.
- YOKE Swage sockets are not recommended for use on fiber core or lang lay rope.

All slings swaged with sockets shall be proof loaded in accordance with ASME B30.9

Forged Closed Swage Wire Rope Socket

Item No.		Rope Size	Before Swage Dimensions (inch)								Max. After Swage Dim.	N.W.
S.C.*	Galvanized	inch	B	D	D1	d	H	K	L	L1	inch	lbs
8-732-06	8-732-06G	1/4	1.38	0.50	0.75	0.27	0.50	3.50	4.33	2.13	0.46	0.4
8-732-08	8-732-08G	5/16	1.63	0.77	0.89	0.34	0.67	4.50	5.50	3.15	0.71	0.7
8-732-10	8-732-10G	3/8	1.63	0.77	0.89	0.41	0.67	4.50	5.50	3.15	0.71	0.7
8-732-11	8-732-11G	7/16	2.00	0.98	1.06	0.48	0.89	5.75	6.93	4.25	0.91	1.5
8-732-13	8-732-13G	1/2	2.00	0.98	1.06	0.55	0.89	5.75	6.93	4.25	0.91	1.3
8-732-14	8-732-14G	9/16	2.40	1.25	1.26	0.62	1.14	7.28	8.70	5.31	1.16	3.1
8-732-16	8-732-16G	5/8	2.40	1.25	1.26	0.67	1.14	7.28	8.70	5.31	1.16	2.9
8-732-19	8-732-19G	3/4	2.87	1.55	1.44	0.82	1.31	8.54	10.20	6.38	1.42	5.1
8-732-22	8-732-22G	7/8	3.11	1.70	1.70	0.94	1.50	10.16	11.97	7.44	1.55	6.8
8-732-26	8-732-26G	1	3.62	1.98	2.05	1.06	1.77	11.54	13.46	8.50	1.80	10.6
8-732-28	8-732-28G	1 1/8	4.02	2.25	2.32	1.19	2.00	12.72	15.04	9.57	2.05	14.7
8-732-32	8-732-32G	1 1/4	4.50	2.53	2.56	1.33	2.25	14.33	16.97	10.63	2.30	21.6
8-732-36	8-732-36G	1 3/8	5.00	2.80	2.56	1.45	2.25	15.83	18.70	11.69	2.56	28.6
8-732-38	8-732-38G	1 1/2	5.50	3.08	2.81	1.61	2.52	17.01	20.12	12.75	2.81	38.1
8-732-45	8-732-45G	1 3/4	6.26	3.39	3.54	1.86	3.00	20.00	23.54	14.88	3.06	52.8
8-732-50	8-732-50G	2	7.24	3.94	3.82	2.13	3.27	23.00	27.64	17.01	3.56	89.1

★ S.C. = Self Colored.

Item No.		Rope Size	Before Swage Dimensions (mm)								Max. After Swage Dim.	N.W.
S.C.*	Galvanized	mm	B	D	D1	d	H	K	L	L1	mm	kg
8-732-06	8-732-06G	6- 7	35	13	19	7	13	89	110	54	12	0.2
8-732-08	8-732-08G	8	41	20	22	9	17	114	140	80	18	0.3
8-732-10	8-732-10G	9-10	41	20	22	11	17	114	140	80	18	0.3
8-732-11	8-732-11G	11-12	51	25	27	12	22	146	176	108	23	0.7
8-732-13	8-732-13G	13	51	25	27	14	22	146	176	108	23	0.6
8-732-14	8-732-14G	14-15	61	32	32	16	29	185	221	135	30	1.4
8-732-16	8-732-16G	16	61	32	32	17	29	185	221	135	30	1.3
8-732-19	8-732-19G	18-20	73	39	36	21	33	217	259	162	36	2.3
8-732-22	8-732-22G	22-23	79	43	43	24	38	258	304	189	39	3.1
8-732-26	8-732-26G	24-25	92	50	52	27	45	293	342	216	46	4.7
8-732-28	8-732-28G	28	102	57	59	30	51	323	382	243	52	6.7
8-732-32	8-732-32G	32	114	64	65	34	57	364	431	270	58	9.8
8-732-36	8-732-36G	35-36	127	71	65	37	57	402	475	297	65	13.0
8-732-38	8-732-38G	38	140	78	71	41	64	432	511	323	71	17.3
8-732-45	8-732-45G	44-45	159	86	90	47	76	508	598	378	78	24.0
8-732-50	8-732-50G	48-51	184	100	97	54	83	584	702	432	90	40.5

★ S.C. = Self Colored.

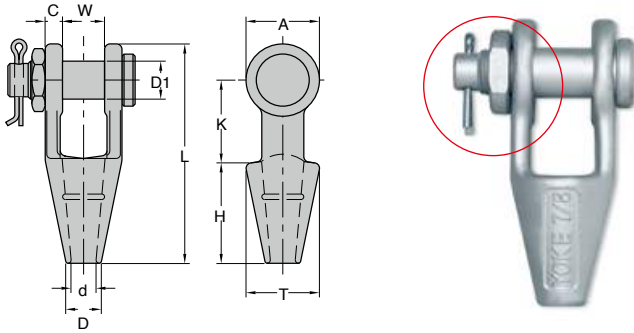

- YOKE Spelter Sockets are forged steel socket through 1-1/2", cast steel 1-5/8" up to 3-3/4".
- YOKE Spelter Sockets properly applied have an efficiency rating of 100% based on the catalog strength of wire rope.
- Socket size 1/4" thru 3/4" use one groove, 7/8" thru 1-1/2" use 2 grooves, 1-5/8" and larger use 3 grooves.
- Open Spelter sockets meet the performance requirements of Federal Specification RR-S-550E ,Type A.

In accordance with ASME B30.9, all assembly slings with poured Spelter shall be proof loaded.

Open Spelter Wire Rope Socket

Item No.		Rope Dia.	Structural Strand Dia.	Ultimate Load	Dimensions (inch)										N.W.
S.C.*	Galvanized	inch	inch	tonnes	A	C	D	D1	d	H	K	L	T	W	lbs
8-733-06	8-733-06G	1/4	-	8	1.31	0.35	0.71	0.67	0.43	2.25	1.56	4.65	1.54	0.91	1.5
8-733-10	8-733-10G	5/16 - 3/8	-	12	1.50	0.44	0.83	0.79	0.51	2.25	1.77	4.84	1.73	0.83	2.0
8-733-13	8-733-13G	7/16 - 1/2	-	20	1.91	0.50	0.98	0.98	0.56	2.48	2.13	5.62	1.96	1.00	3.5
8-733-16	8-733-16G	9/16 - 5/8	1/2	27	2.28	0.55	1.14	1.19	0.70	2.99	2.52	6.77	2.25	1.26	4.9
8-733-19	8-733-19G	3/4	9/16 - 5/8	43	2.64	0.62	1.26	1.38	0.81	3.62	3.00	7.96	2.64	1.50	7.5
8-733-22	8-733-22G	7/8	11/16 - 3/4	55	3.17	0.80	1.50	1.63	0.94	4.02	3.50	9.25	3.35	1.77	11.9
8-733-26	8-733-26G	1	13/16 - 7/8	76	3.78	0.91	1.75	2.00	1.14	4.48	4.02	10.55	3.75	2.05	18.7
8-733-28	8-733-28G	1 1/8	15/16 - 1	92	4.12	1.00	2.00	2.25	1.26	5.00	4.62	11.81	4.12	2.25	25.6
8-733-36	8-733-36G	1 1/4 - 1 3/8	1 1/16 - 1 1/8	136	4.75	1.14	2.25	2.50	1.50	5.51	5.00	13.20	4.72	2.52	35.2
8-733-38	8-733-38G	1 1/2	1 3/16 - 1 1/4	170	5.38	1.19	2.75	2.75	1.63	5.98	5.98	15.12	5.25	2.99	52.9
**8-733-40	8-733-40G	1-5/8	1-5/16 - 1-5/8	188	5.69	1.29	2.89	3.00	1.76	6.47	6.55	16.11	5.30	2.96	54.8
**8-733-44	8-733-44G	1-3/4-1-7/8	1-7/16 - 1-5/8	268	6.44	1.56	3.04	3.50	1.99	7.49	7.06	18.10	6.28	3.47	81.8
**8-733-50	8-733-50G	2-2-1/8	1-11/16 - 1-3/4	291	6.94	1.79	3.67	3.74	2.22	8.46	8.89	21.29	7.18	3.98	129.8
**8-733-56	8-733-56G	2-1/4-2-3/8	1-13/16 - 1-7/8	360	7.68	2.11	3.98	4.21	2.57	9.09	9.91	23.28	8.03	4.45	167.2
**8-733-64	8-733-64G	2-1/2-2-5/8	1-15/16 - 2-1/8	424	8.42	2.38	4.45	4.72	2.85	9.83	10.69	25.27	9.01	4.95	250.8
**8-733-70	8-733-70G	2-3/4-2-7/8	2-3/16 - 2-7/16	511	8.93	2.85	4.76	4.84	3.08	10.88	10.88	26.99	10.22	5.19	314.6
**8-733-75	8-733-75G	3-3-1/8	2-1/2 - 2-5/8	563	9.40	2.96	5.11	5.11	3.43	12.05	11.23	28.74	10.96	5.69	378.4
**8-733-82	8-733-82G	3-1/4-3-3/8	2-3/4 - 2-7/8	722	9.91	3.08	5.58	5.42	3.63	12.91	11.90	30.58	11.62	6.20	433.4
**8-733-88	8-733-88G	3-1/2-3-5/8	3 - 3-1/8	779	10.69	3.20	6.36	5.97	3.86	13.85	12.44	32.96	12.25	6.67	561.0
**8-733-94	8-733-94G	3-3/4-4	-	875	12.40	3.47	7.10	6.94	4.21	14.66	13.57	35.92	13.61	7.45	781.0

*S.C. = Self Colored.

**Cast alloy steel

Item No.		Rope Dia.	Structural Strand Dia.	Ultimate Load	Dimensions (mm)										N.W.
S.C.*	Galvanized	mm	mm	tonnes	A	C	D	D1	d	H	K	L	T	W	kg
8-733-06	8-733-06G	6 - 7	-	8	33	9	18	17	11	57	40	115	39	23	0.7
8-733-10	8-733-10G	8 - 10	-	12	38	11	21	20	13	57	45	123	44	21	0.9
8-733-13	8-733-13G	11 - 13	-	20	48	13	25	25	15	63	54	142	50	25	1.6
8-733-16	8-733-16G	14 - 16	13	27	58	14	29	30	18	76	64	172	57	32	2.2
8-733-19	8-733-19G	18 - 20	14 - 16	43	67	16	32	35	22	92	76	202	67	38	3.4
8-733-22	8-733-22G	22 - 23	18 - 20	55	80	20	38	41	24	102	89	235	85	45	5.4
8-733-26	8-733-26G	24 - 26	22 - 23	76	96	23	44	51	29	114	102	268	95	52	8.5
8-733-28	8-733-28G	28 - 30	24 - 25	92	105	25	51	56	32	127	117	300	105	57	11.6
8-733-36	8-733-36G	32 - 35	26 - 28	136	121	29	57	62	38	140	127	335	120	64	16.0
8-733-38	8-733-38G	36 - 39	30 - 32	170	137	30	70	70	41	152	152	384	133	76	24.0
**8-733-40	8-733-40G	40 - 42	33-35	188	146	33	74	77	45	166	168	413	136	76	24.9
**8-733-44	8-733-44G	44 - 48	36-40	268	165	40	78	89.7	51	192	181	464	161	89	37.2
**8-733-50	8-733-50G	50 - 54	42-45	291	178	46	94	96	57	217	228	546	184	102	59.0
**8-733-56	8-733-56G	56 - 60	46-48	360	197	54	102	108	66	233	254	597	206	114	76.0
**8-733-64	8-733-64G	64 - 67	50-54	424	216	61	114	121	73	252	274	648	231	127	114.0
**8-733-70	8-733-70G	70 - 73	56-62	511	229	73	122	124	79	279	279	692	262	133	143.0
**8-733-75	8-733-75G	75 - 80	64-67	563	241	76	131	131	88	309	288	737	281	146	172.0
**8-733-82	8-733-82G	82 - 86	70-73	722	254	79	143	139	93	331	305	784	298	159	197.0
**8-733-88	8-733-88G	88 - 92	76-80	779	274	82	163	153	99	355	319	845	314	171	255.0
**8-733-94	8-733-94G	94 - 102	-	875	318	89	182	178	108	376	348	921	349	191	355.0

*S.C. = Self Colored.

**Cast alloy steel

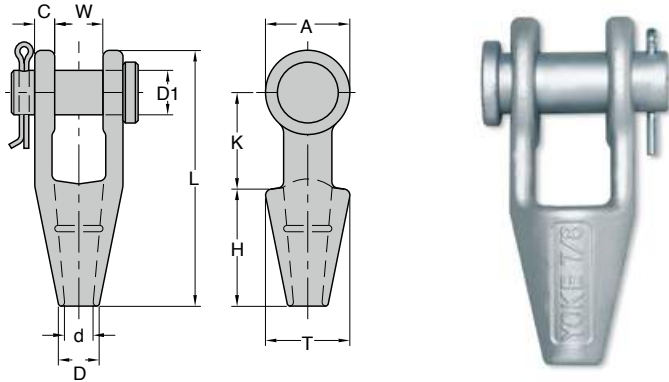

In accordance with ASME B30.9, all assembly slings with poured Spelter shall be proof loaded.

- YOKE Spelter Sockets are forged from special bar quality carbon steel with very finest hardness controlled.
- YOKE Spelter Sockets properly applied have an efficiency rating of 100% based on the catalog strength of wire rope.
- Socket size 1/4" thru 3/4" use one groove, 7/8" thru 1-1/2" use 2 grooves.
- Open Spelter sockets meet the performance requirements of Federal Specification RR-S-550E, Type A.

Forged Open Spelter Wire Rope Socket

with Round Pin

Item No.		Rope Dia.	Structural Strand Dia.	Ultimate Load	Dimensions (inch)										N.W.
S.C.*	Galvanized	inch	inch	tonnes	A	C	D	D1	d	H	K	L	T	W	lbs
8-734-06	8-734-06G	1/4	-	8	1.31	0.35	0.71	0.67	0.43	2.25	1.56	4.65	1.54	0.91	1.1
8-734-10	8-734-10G	5/16 - 3/8	-	12	1.50	0.44	0.83	0.79	0.51	2.25	1.77	4.84	1.73	0.83	1.3
8-734-13	8-734-13G	7/16 - 1/2	-	20	1.91	0.50	0.98	0.98	0.56	2.48	2.13	5.62	1.96	1.00	2.4
8-734-16	8-734-16G	9/16 - 5/8	1/2	27	2.28	0.55	1.14	1.19	0.70	3.00	2.52	6.77	2.25	1.26	4.0
8-734-19	8-734-19G	3/4	9/16 - 5/8	43	2.64	0.62	1.26	1.38	0.81	3.62	3.00	7.96	2.64	1.50	5.7
8-734-22	8-734-22G	7/8	11/16 - 3/4	55	3.17	0.80	1.50	1.63	0.94	4.02	3.50	9.25	3.35	1.77	10.3
8-734-26	8-734-26G	1	13/16 - 7/8	76	3.78	0.91	1.75	2.00	1.14	4.48	4.02	10.55	3.75	2.05	16.3
8-734-28	8-734-28G	1 1/8	15/16 - 1	92	4.12	1.00	2.00	2.25	1.26	5.00	4.62	11.81	4.12	2.25	22.2
8-734-36	8-734-36G	1 1/4 - 1 3/8	1 1/16 - 1 1/8	136	4.75	1.14	2.25	2.50	1.50	5.51	5.00	13.20	4.72	2.52	32.8
8-734-38	8-734-38G	1 1/2	1 3/16 - 1 1/4	170	5.38	1.19	2.75	2.75	1.63	6.00	6.00	15.12	5.25	3.00	45.5

*S.C. = Self Colored.

Item No.		Rope Dia.	Structural Strand Dia.	Ultimate Load	Dimensions (mm)										N.W.
S.C.*	Galvanized	mm	mm	tonnes	A	C	D	D1	d	H	K	L	T	W	kg
8-734-06	8-734-06G	6 - 7	-	8	33	9	18	17	11	57	40	115	39	23	0.5
8-734-10	8-734-10G	8 - 10	-	12	38	11	21	20	13	57	45	123	44	21	0.6
8-734-13	8-734-13G	11 - 13	-	20	48	13	25	25	15	63	54	142	50	25	1.1
8-734-16	8-734-16G	14 - 16	13	27	58	14	29	30	18	76	64	172	57	32	1.8
8-734-19	8-734-19G	18 - 20	14 - 16	43	67	16	32	35	22	92	76	202	67	38	2.6
8-734-22	8-734-22G	22 - 23	18 - 20	55	80	20	38	41	24	102	89	235	85	45	4.7
8-734-26	8-734-26G	24 - 26	22 - 23	76	96	23	44	51	29	114	102	268	95	52	7.4
8-734-28	8-734-28G	28 - 30	24 - 25	92	105	25	51	56	32	127	117	300	105	57	10.1
8-734-36	8-734-36G	32 - 35	26 - 28	136	121	29	57	62	38	140	127	335	120	64	14.9
8-734-38	8-734-38G	36 - 39	30 - 32	170	137	30	70	70	41	152	152	384	133	76	20.7

*S.C. = Self Colored.

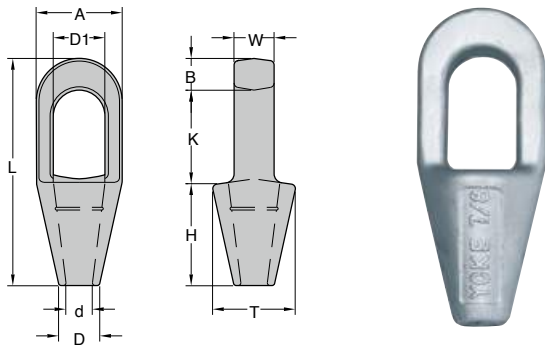

- YOKE Spelter Sockets are forged steel socket through 1-1/2", cast steel 1-5/8" up to 3-3/4".
- YOKE Spelter Sockets properly applied have an efficiency rating of 100% based on the catalog strength of wire rope.
- Socket size 1/4" thru 3/4" use one groove, 7/8" thru 1-1/2" use 2 grooves, 1-5/8" and larger use 3 grooves.
- Open Spelter sockets meet the performance requirements of Federal Specification RR-S-550E ,Type A.

Forged Closed Spelter Wire Rope Socket

In accordance with ASME B30.9, all assembly slings with poured spelter shall be proof loaded.

Item No.		Rope Dia.	Structural Strand Dia.	Ultimate Load	Dimensions (inch)										N.W.
S.C.*	Galvanized	inch	inch	tonnes	A	B	D	D1	d	H	K	L	T	W	lbs
8-735-06	8-735-06G	1/4	-	8	1.50	0.50	0.71	0.88	0.43	2.25	1.73	4.50	1.50	0.50	0.7
8-735-10	8-735-10G	5/16 - 3/8	-	12	1.69	0.62	0.83	0.98	0.50	2.25	2.00	4.88	1.70	0.71	0.9
8-735-13	8-735-13G	7/16 - 1/2	-	20	2.00	0.71	0.98	1.19	0.55	2.52	2.25	5.43	1.96	0.87	1.5
8-735-16	8-735-16G	9/16 - 5/8	1/2	30.8	2.63	0.83	1.12	1.41	0.71	3.00	2.52	6.31	2.50	0.98	2.6
8-735-19	8-735-19G	3/4	9/16 - 5/8	43.5	3.00	1.06	1.26	1.61	0.81	3.50	3.00	7.58	2.75	1.26	4.4
8-735-22	8-735-22G	7/8	11/16 - 3/4	65.3	3.63	1.26	1.50	1.89	0.94	3.98	3.50	8.75	3.46	1.50	7.9
8-735-26	8-735-26G	1	13/16 - 7/8	81.6	4.13	1.38	1.77	2.28	1.14	4.50	4.02	9.88	3.78	1.77	10.8
8-735-28	8-735-28G	1 1/8	15/16 - 1	100	4.50	1.50	2.00	2.56	1.26	5.00	4.50	10.98	4.12	2.00	15.8
8-735-36	8-735-36G	1 1/4 - 1 3/8	1 1/16 - 1 1/8	136	5.31	1.63	2.25	2.80	1.50	5.50	5.00	12.31	4.75	2.25	23.1
8-735-38	8-735-38G	1 1/2	1 3/16 - 1 1/4	170	5.31	1.93	2.75	3.19	1.63	6.00	6.00	13.94	5.25	2.52	31.5
**8-735-40	8-735-40G	1-5/8	1-5/16 - 1-5/8	188	5.69	2.11	2.96	3.24	1.72	6.44	6.67	15.21	5.58	2.73	36.0
**8-735-44	8-735-44G	1-3/4-1-7/8	1-7/16 - 1-5/8	268	6.67	2.18	3.12	3.74	1.99	7.45	7.72	17.36	6.51	2.96	57.0
**8-735-50	8-735-50G	2-2-1/8	1-11/16 - 1-3/4	309	7.57	2.42	3.71	4.33	2.22	8.42	8.74	19.58	7.41	3.24	79.0
**8-735-56	8-735-56G	2-1/4-2-3/8	1-13/16 - 1-7/8	360	8.42	2.73	4.10	4.95	2.61	8.93	9.67	21.33	8.19	3.59	105.0
**8-735-64	8-735-64G	2-1/2-2-5/8	1-15/16 - 2-1/8	424	9.40	3.08	4.45	5.46	2.93	9.67	10.53	23.28	9.17	3.98	140.0
**8-735-70	8-735-70G	2-3/4-2-7/8	2-3/16 - 2-7/16	549	10.65	3.12	4.84	6.20	3.12	10.88	11.15	25.16	10.34	4.84	220.0
**8-735-75	8-735-75G	3-3-1/8	2-1/2 - 2-5/8	656	11.39	3.35	5.19	6.67	3.43	11.90	11.62	26.87	11.19	5.19	275.0
**8-735-82	8-735-82G	3-1/4-3-3/8	2-3/4 - 2-7/8	750	12.13	3.98	5.69	7.18	3.67	12.87	12.13	28.98	11.90	5.69	312.0
**8-735-88	8-735-88G	3-1/2-3-5/8	3 - 3-1/8	820	12.87	3.98	6.24	7.68	3.94	13.88	12.87	30.73	12.64	6.20	398.0
**8-735-94	8-735-94G	3-3/4-4	-	1005	14.12	4.21	7.18	8.42	4.29	14.86	13.88	32.96	13.88	6.94	541.0

*S.C. = Self Colored.

**Cast alloy steel

Item No.		Rope Dia.	Structural Strand Dia.	Ultimate Load	Dimensions (mm)										N.W.
S.C.*	Galvanized	mm	mm	tonnes	A	B	D	D1	d	H	K	L	T	W	kg
8-735-06	8-735-06G	6- 7	-	8	38	13	18	22	11	57	44	114	38	13	0.3
8-735-10	8-735-10G	8-10	-	12	43	16	21	25	13	57	51	124	43	18	0.4
8-735-13	8-735-13G	11-13	-	20	51	18	25	30	14	64	57	138	50	22	0.7
8-735-16	8-735-16G	14-16	13	30.8	67	21	28	36	18	76	64	160	63	25	1.2
8-735-19	8-735-19G	18-20	14-16	43.5	76	27	32	41	21	89	76	192	70	32	2.0
8-735-22	8-735-22G	22-23	18-20	65.3	92	32	38	48	24	101	89	222	88	38	3.6
8-735-26	8-735-26G	24-26	22-23	81.6	104	35	45	58	29	114	102	251	96	45	4.9
8-735-28	8-735-28G	28-30	24-25	100	114	38	51	65	32	127	114	279	105	50	7.2
8-735-36	8-735-36G	32-35	26-28	136	135	41	57	71	38	140	127	308	121	57	10.5
8-735-38	8-735-38G	36-39	30-32	170	135	49	70	81	41	152	152	354	133	64	14.3
**8-735-40	8-735-40G	40-42	33-35	188	146	54	76	83	44	165	171	390	143	70	16.3
**8-735-44	8-735-44G	44-48	36-40	268	171	56	80	96	51	191	198	445	167	76	26.0
**8-735-50	8-735-50G	50-54	42-45	309	194	62	95	111	57	216	224	502	190	83	35.8
**8-735-56	8-735-56G	56-60	46-48	360	216	70	105	127	67	229	248	547	210	92	47.6
**8-735-64	8-735-64G	64-67	50-54	424	241	79	114	140	75	248	270	597	235	102	63.5
**8-735-70	8-735-70G	70-73	56-62	549	273	80	124	159	80	279	286	645	265	124	99.7
**8-735-75	8-735-75G	75-80	64-67	656	292	86	133	171	88	305	298	689	287	133	125.0
**8-735-82	8-735-82G	82-86	70-73	750	311	102	146	184	94	330	311	743	305	146	142.0
**8-735-88	8-735-88G	88-92	76-80	820	330	102	160	197	101	356	330	788	324	159	181.0
**8-735-94	8-735-94G	94-102	-	1005	362	108	184	216	110	381	356	845	356	178	246.0

*S.C. = Self Colored.

**Cast alloy steel



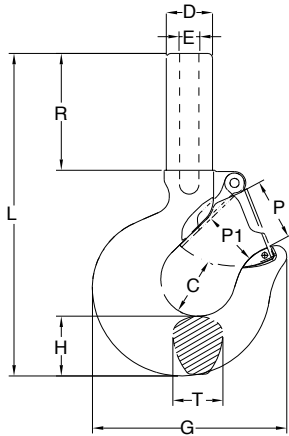

- Yoke Swaging Hoist Hooks are forged from special bar quality carbon steel with very special Quenched and Tempered.
- Yoke Swaging Hoist Hooks properly applied have an efficiency rating of 95% based on the catalog strength of wire rope.
- Yoke Swaging Hoist Hooks are recommended for use with 6 x 19 or 6 x 37, IPS or XIP, FC or IWRC wire rope.
- Yoke Swaging Hoist Hooks are not recommended for use on fiber core or lang lay rope.

All slings swaged with shall be proof loaded in accordance with ANSI B30.9

Swaging Hoist Hook

Item No.		Rope Size	Hook Feature code	Working Load Limit	Dimensions (inch)											Max. After Swage Dim.	N.W.
with latch	without latch	inch		tonnes*	C	D	E	G	H	L	P	P1	R	T	inch	lbs	
8-739.SC-0075	8-739.SC/0-0075	3/6	AA	0.4	0.97	0.70	0.44	3.07	0.75	5.32	1.02	0.95	2.00	0.63	0.40	0.7	
8-739.SC-01	8-739.SC/0-01	1/4	BB	0.7	0.97	0.90	0.50	3.15	0.87	5.75	1.06	1.00	2.30	0.71	0.46	0.9	
8-739.SC-015	8-739.SC/0-015	5/16	CC	1.1	1.03	1.02	0.67	3.58	1.00	6.46	1.14	1.06	2.60	0.88	0.58	1.3	
8-739.SC-02	8-739.SC/0-02	5/16	DD	1.1	1.03	1.14	0.77	4.02	1.18	7.28	1.22	1.18	2.80	0.94	0.71	1.8	
8-739.SC-02D	8-739.SC/0-02D	3/8	DD	1.6	1.16	1.14	0.77	4.02	1.18	7.28	1.22	1.18	2.80	0.94	0.71	1.8	
8-739.SC-03	8-739.SC/0-03	7/16	EE	2.1	1.53	1.18	0.98	5.12	1.46	8.89	1.61	1.42	3.40	1.31	0.91	3.7	
8-739.SC-03D	8-739.SC/0-03D	1/2	EE	2.8	1.53	1.18	0.98	5.12	1.46	8.89	1.61	1.42	3.40	1.31	0.91	3.5	
8-739.SC-05	8-739.SC/0-05	9/16	FF	3.5	1.94	1.49	1.25	6.54	1.82	10.98	2.13	1.69	3.80	1.66	1.16	7.5	
8-739.SC-05D	8-739.SC/0-05D	5/8	FF	4.3	1.94	1.49	1.25	6.54	1.82	10.98	2.13	1.69	3.80	1.66	1.16	7.3	
8-739.SC-075	8-739.SC/0-075	3/4	GG	6.2	2.46	1.77	1.53	7.72	2.28	12.91	2.40	2.24	5.00	1.88	1.42	12.8	
8-739.SC-10	8-739.SC/0-10	7/8	HH	8.3	2.59	2.00	1.70	8.70	2.60	13.54	2.83	2.44	5.00	2.19	1.55	18.7	
8-739.SC-15	8-739.SC/0-15	1	JJ	11.0	2.81	2.63	1.98	10.91	3.01	16.97	3.39	3.19	5.80	2.69	1.80	34.1	
8-739.SC-20	8-739.SC/0-20	1 1/8	KK	14.0	3.44	2.75	2.25	13.90	3.62	23.07	3.50	3.27	10.00	3.00	2.05	66.4	

★ S.C. = Self Colored.

Item No.		Rope Size	Hook Feature code	Working Load Limit	Dimensions (mm)											Max. After Swage Dim.	N.W.
with latch	without latch	mm		tonnes*	C	D	E	G	H	L	P	P1	R	T	mm	kg	
8-739.SC-0075	8-739.SC/0-0075	5	AA	0.4	25	18	11	78	19	135	26	24	51	16	10	0.3	
8-739.SC-01	8-739.SC/0-01	6- 7	BB	0.7	25	23	13	80	22	146	27	25	58	18	12	0.4	
8-739.SC-015	8-739.SC/0-015	8	CC	1.1	26	26	17	91	25	164	29	27	66	22	15	0.6	
8-739.SC-02	8-739.SC/0-02	8	DD	1.1	29	29	20	102	30	185	31	30	71	24	18	0.8	
8-739.SC-02D	8-739.SC/0-02D	9-10	DD	1.6	29	29	20	102	30	185	31	30	71	24	18	0.8	
8-739.SC-03	8-739.SC/0-03	11-12	EE	2.1	38	30	25	130	38	226	41	36	86	33	23	1.7	
8-739.SC-03D	8-739.SC/0-03D	13	EE	2.8	38	30	25	130	38	226	41	36	86	33	23	1.6	
8-739.SC-05	8-739.SC/0-05	14-15	FF	3.5	49	38	32	166	46	279	54	43	97	42	30	3.4	
8-739.SC-05D	8-739.SC/0-05D	16	FF	4.3	49	38	32	166	46	279	54	43	97	42	30	3.3	
8-739.SC-075	8-739.SC/0-075	18-20	GG	6.2	62	45	39	196	58	328	61	57	127	48	36	5.8	
8-739.SC-10	8-739.SC/0-10	22-23	HH	8.3	65	51	43	221	66	344	72	62	127	56	39	8.5	
8-739.SC-15	8-739.SC/0-15	24-25	JJ	11.0	71	67	50	277	77	431	86	81	147	68	46	15.5	
8-739.SC-20	8-739.SC/0-20	28	KK	14.0	87	70	57	353	92	586	89	83	254	76	52	30.2	

★ S.C. = Self Colored.



Steel Swage Sleeve

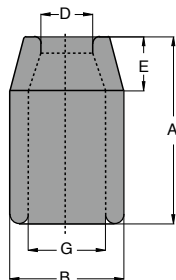

Item No.	For Rope Size	Before Swage Dimensions (inch)					Max. After Swage Dim.	N.W.
		inch	A	B	D	E		
902-06	1/4	1	0.66	0.31	0.28	0.47	0.57	0.05
902-08	5/16	1.5	0.91	0.38	0.44	0.62	0.75	0.14
902-10	3/8	1.5	0.91	0.47	0.39	0.66	0.75	0.14
902-11	7/16	2	1.22	0.53	0.65	0.85	1.01	0.3
902-13	1/2	2	1.22	0.63	0.56	0.91	1.01	0.4
902-16	5/8	2.75	1.47	0.75	0.63	1.09	1.24	0.6
902-19	3/4	3.19	1.72	0.91	0.84	1.28	1.46	0.9
902-22	7/8	3.56	2.03	1.03	1.00	1.53	1.68	1.3
902-26	1	4	2.28	1.16	1.13	1.72	1.93	2.0
902-28	1 1/8	4.81	2.5	1.28	1.25	1.94	2.13	2.6
902-32	1 1/4	5.19	2.78	1.44	1.41	2.16	2.32	3.6
902-36	1 3/8	5.81	3	1.56	1.56	2.38	2.52	4.2
902-38	1 1/2	6.25	3.25	1.69	1.69	2.63	2.71	5.0
902-45	1 3/4	7.25	3.84	1.94	1.97	3.13	3.10	8.0
902-50	2	8.5	4.38	2.25	2.25	3.63	3.56	11.3
902-58	2 1/4	9.56	5.03	2.50	2.53	4.03	4.12	19.4
902-64	2 1/2	10.50	5.50	2.75	2.81	4.50	4.50	23.5
902-70	2 3/4	11.50	5.75	3.00	3.09	4.75	4.70	28.0
902-75	3	12.00	6.00	3.25	3.38	5.00	4.96	29.4
902-89	3 1/2	14.00	7.00	3.88	3.94	5.84	5.77	46.4
902-95	3 3/4	15.00	7.50	4.06	4.25	6.31	6.23	55.0
902-100	4	16.00	8.13	4.38	4.50	6.81	6.69	68.0
902-115	4 1/2	18.00	9.13	4.88	5.06	7.66	7.45	100.1
902-130	5	20.00	10.52	5.50	5.63	8.73	8.28	145.5
902-150	6	24.00	12.54	6.50	6.75	10.20	9.93	271.2

⚠ Recommended to be used with 6x19, 6x25, 6x29, 6x37 IPS XIP (EIP), FC or IWRC wire rope. If using with any other type of construction or grade of wire rope, it is recommended to make the breaking load test of the swaged termination to prove the adequacy of the assembly to be manufactured.

Steel Duplex Oval Sleeves

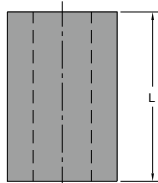
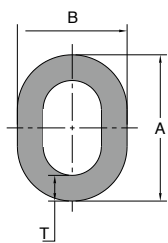

Item No.	For Rope Size	Before Swage Dimensions (inch)				Max. After Swage Dim.	N.W.
		inch	A	B	L		
903-08	5/16	1.08	0.81	1.25	0.19	0.77	0.17
903-10	3/8	1.12	0.81	1.25	0.14	0.77	0.13
903-11	7/16	1.41	1.02	1.63	0.19	1.03	0.31
903-13	1/2	1.44	1.02	1.63	0.16	1.03	0.27
903-14	9/16	1.72	1.23	2.25	0.23	1.29	0.63
903-16	5/8	1.84	1.28	2.25	0.20	1.29	0.54
903-19	3/4	2.16	1.52	2.63	0.23	1.55	0.90
903-22	7/8	2.50	1.75	2.88	0.27	1.80	1.26
903-25	1	2.84	2.00	3.06	0.33	2.05	1.87
903-32	1 1/4	3.50	2.50	4.06	0.38	2.56	3.84

⚠ Recommended to be used with 6x19, 6x25, 6x29, 6x37 IPS XIP (EIP), FC or IWRC wire rope. If using with any other type of construction or grade of wire rope, it is recommended to make the breaking load test of the swaged termination to prove the adequacy of the assembly to be manufactured.

⚠ Just one step will finish the swaging, turning the sleeves (ferrules) 90° and swaging again is not recommended.

Steel Swage Buttons

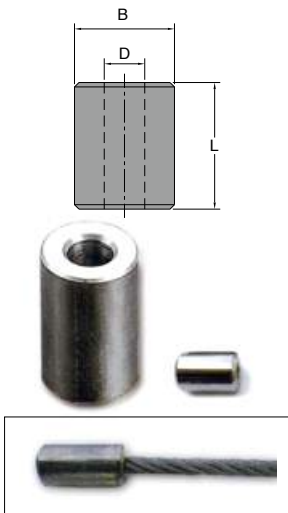

Item No.	For Rope Size	Before Swage Dimensions (inch)			Max. After Swage Dim.	N.W.
		B	D	L		
	inch				inch	lbs
903Y-03	1/8	0.44	0.14	0.50	0.40	0.02
903Y-05	3/16	0.56	0.20	0.70	0.52	0.04
903Y-06	1/4	0.63	0.30	1.06	0.58	0.08
903Y-08	5/16	0.88	0.36	1.13	0.77	0.16
903Y-10	3/8	0.88	0.42	1.48	0.77	0.15
903Y-11	7/16	1.13	0.48	1.63	1.03	0.30
903Y-13	1/2	1.31	0.55	1.89	1.16	0.50
903Y-14	9/16	1.44	0.61	2.02	1.29	0.70
903Y-16	5/8	1.56	0.67	2.42	1.42	1.00
903Y-19	3/4	1.69	0.79	2.73	1.55	1.31
903Y-22	7/8	2.00	0.94	3.27	1.80	2.20
903Y-25	1	2.25	1.06	3.67	2.05	3.10
903Y-28	1 1/8	2.56	1.19	4.05	2.30	4.50
903Y-32	1 1/4	2.81	1.33	4.58	2.56	6.51

⚠ Recommended to be used with 6x19, 6x25, 6x29, 6x37 IPS XIP (EIP), FC or IWRC wire rope. If using with any other type of construction or grade of wire rope, it is recommended to make the breaking load test of the swaged termination to prove the adequacy of the assembly to be manufactured.

Stainless Steel One-Piece Sleeves

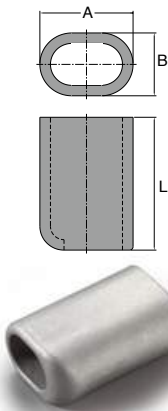

Item No.	For Rope Size	Before Swage Dimensions (inch)			Max. After Swage Dim.	N.W.
		A	B	L		
	inch				inch	lbs
9041-06	1/4	3/4	9/16	7/8	0.53	0.03
9041-08	5/16	1 1/8	25/32	1 19/32	0.76	0.18
9041-10	3/8	1 1/8	13/16	1 23/32	0.76	0.14
9041-11	7/16	1 7/16	1 1/32	2 1/32	1.01	0.35
9041-13	1/2	1 7/16	1	2	1.01	0.31
9041-14	9/16	1 3/4	1 3/16	2 1/4	1.27	0.60
9041-16	5/8	1 13/16	1 1/4	2 3/8	1.27	0.60
9041-19	3/4	2 1/8	1 7/16	3 1/16	1.53	1.00
9041-22	7/8	2 1/2	3 3/8	3 1/4	1.76	1.50
9041-25	1	2 7/8	3 7/8	3 3/4	2.04	2.00

⚠ Recommended to be used with 6x19, 6x25, 6x29, 6x37 IPS XIP (EIP), FC or IWRC wire rope. If using with any other type of construction or grade of wire rope, it is recommended to make the breaking load test of the swaged termination to prove the adequacy of the assembly to be manufactured.

⚠ Just one step will finish the swaging, turning the sleeves(ferrules) 90° and swaging again is not recommended.

Stainless Steel Two-Piece Sleeves

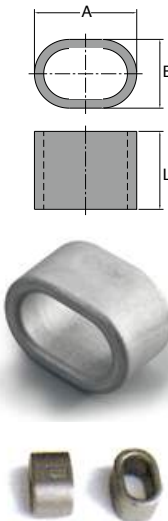

Item No.	For Rope Size	Before Swage Dimensions (inch)			Max. After Swage Dim.	N.W.
		A	B	L		
	inch				inch	lbs
9042-13	1/2	1 3/8	15/16	1 1/16	1.01	0.20
9042-14	9/16	1 11/16	1 3/16	1 1/4	1.27	0.31
9042-16	5/8	1 13/16	1 13/16	1 1/16	1.27	0.30
9042-19	3/4	2 1/8	1 3/8	1 3/16	1.53	0.50
9042-22	7/8	2 1/2	1 4/3	1 3/8	1.76	0.70
9042-25	1	2 3/4	1 13/16	1 9/16	2.04	1.00
9042-28	1 1/8	3 3/16	2	1 7/8	2.26	1.50
9042-32	1 1/4	3 3/8	2 3/8	2 1/8	2.51	2.00
9042-35	1 3/8	3 9/16	2 5/16	2 1/8	2.51	2.00
9042-38	1 1/2	3 7/8	2 1/2	2 1/4	2.70	2.00
9042-42	1 5/8	4 5/16	2 13/16	2 3/8	3.08	3.00
9042-45	1 3/4	4 7/16	2 13/16	2 1/2	3.08	3.30
9042-50	2	5	3 3/16	2 7/8	3.52	4.30
9042-57	2 1/4	5 11/16	3 3/4	3 1/8	4.02	6.51
9042-64	2 1/2	6 3/8	4	3 1/8	4.39	7.51

⚠ Recommended to be used with 6x19, 6x25, 6x29, 6x37 IPS XIP (EIP), FC or IWRC wire rope. If using with any other type of construction or grade of wire rope, it is recommended to make the breaking load test of the swaged termination to prove the adequacy of the assembly to be manufactured.

⚠ Just one step will finish the swaging, turning the sleeves(ferrules) 90° and swaging again is not recommended.

Aluminum Ferrules Spec. acc. to EN13411-3 (DIN 3093)

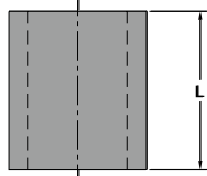
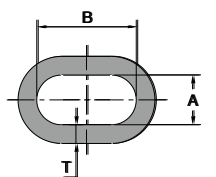

Item No.	For Rope	Before Swage Dimensions (mm)				Max. After	N.W.
	Size					Swage Dim.	(PER 1000 PC)
	mm	A	B	L	T	mm	kg
901-001	1	1.20	2.40	5	0.65	2	0.094
901-001P5	1.5	1.70	3.40	6	0.75	3	0.211
901-002	2	2.20	4.40	7	0.85	4	0.375
901-002P5	2.5	2.70	5.40	9	1.05	5	0.499
901-003	3	3.30	6.60	11	1.25	6	0.843
901-003P5	3.5	3.80	7.60	13	1.50	7	1.32
901-004	4	4.40	8.80	14	1.70	8	1.81
901-004P5	4.5	4.90	9.80	16	1.90	9	2.61
901-005	5	5.50	11.00	18	2.10	10	3.57
901-006	6	6.60	13.20	21	2.50	12	5.86
901-006P5	6.5	7.20	14.40	23	2.70	13	7.55
901-007	7	7.80	15.60	25	2.90	14	9.50
901-008	8	8.80	17.60	28	3.30	16	13.70
901-009	9	9.90	19.80	32	3.70	18	19.80
901-010	10	10.90	21.80	35	4.10	20	26.40
901-011	11	12.10	24.20	39	4.50	22	35.80
901-012	12	13.20	26.40	42	4.90	24	45.80
901-013	13	14.20	28.40	46	5.40	26	59.70
901-014	14	15.30	30.60	49	5.80	28	73.50
901-016	16	17.50	35.00	56	6.70	32	111
901-018	18	19.60	39.20	63	7.60	36	156
901-020	20	21.70	43.40	70	8.40	40	217
901-022	22	24.30	48.60	77	9.20	44	292
901-024	24	26.40	52.80	84	10.00	48	376
901-026	26	28.50	57.00	91	10.90	52	481
901-028	28	31.00	62.00	98	11.70	56	603
901-030	30	33.10	66.20	105	12.50	60	739
901-032	32	35.20	70.40	112	13.40	64	897
901-034	34	37.80	75.60	119	14.20	68	1077
901-036	36	39.80	79.60	126	15.00	72	1275
901-038	38	41.90	83.80	133	15.80	76	1503
901-040	40	44.00	88.00	140	16.60	80	1734
901-042	42	46.20	92.40	147	17.50	84	2024
901-044	44	48.40	96.80	154	18.30	88	2314
901-046	46	50.60	101.20	161	19.20	92	2662
901-048	48	52.80	105.60	168	20.00	96	3010
901-050	50	55.00	110.00	175	20.80	100	3412
901-052	52	57.20	114.40	182	21.60	104	3813
901-054	54	59.40	118.80	189	22.50	108	4293
901-056	56	61.60	123.20	196	23.30	112	4772
901-058	58	63.80	127.60	203	24.20	116	5326
901-060	60	66.00	132.00	210	25.00	120	5880

* Sizes not mentioned in the EN13411-3 (DIN3093) and others up to #104 are all available.

⚠ Just one step will finish the swaging, turning the sleeves(ferrules) 90° and swaging again is not recommended.



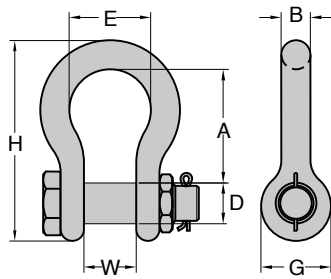

- Shackles are Type Approved by DNV & ABS.
- Shackles are forged alloy steel with alloy pin.
- Size and the Working Load Limit permanently shown on each shackle.
- All shackles with Batch Code which links to Test Certificate and quality traceability.
- 100% magnaflux crack detection during manufacturing.
- 20,000 cycle fatigue rated to 1.5 times Working Load Limit.

YOKE 8-808 Bolt Type Anchor Shackles meet the performance requirements of Federal Specification RR-C-271F, Type 4A , Grade B, Class 3.

Type Approval



Forged Alloy Anchor Shackle

with Bolt Pin

Item No.	Nominal Size	Working Load Limit	Dimensions (inch)							N.W.
	inch		tonnes*	A	B	D	E	G	H	
8-808-08	5/16	1.2	1.22	0.31	0.37	0.82	0.75	2.13	0.47	0.2
8-808-10	3/8	2	1.42	0.39	0.43	1.02	0.91	2.56	0.63	0.2
8-808-11	7/16	2.7	1.70	0.43	0.51	1.18	1.06	2.95	0.75	0.4
8-808-13	1/2	3.3	1.85	0.52	0.63	1.30	1.18	3.34	0.79	0.7
8-808-16	5/8	5	2.40	0.63	0.75	1.77	1.53	4.21	1.06	1.5
8-808-19	3/4	7	2.83	0.75	0.87	1.97	1.81	5.04	1.30	2.2
8-808-22	7/8	9.5	3.39	0.87	1.02	2.28	2.09	5.91	1.50	3.7
8-808-26	1	12.5	3.78	1.02	1.10	2.68	2.36	6.57	1.73	5.3
8-808-28	1 1/8	15	4.37	1.10	1.26	2.91	2.68	7.52	1.81	7.5
8-808-32	1 1/4	18	4.76	1.26	1.42	3.22	2.99	8.07	2.12	10.6
8-808-36	1 3/8	21	5.28	1.42	1.50	3.62	3.31	9.13	2.32	14.3
8-808-38	1 1/2	30	5.57	1.50	1.77	3.90	3.62	10.00	2.36	19.1
8-808-45	1 3/4	40	7.00	1.85	2.00	5.00	4.17	12.32	2.87	38.5
8-808-50	2	55	7.76	2.09	2.24	5.75	4.80	13.66	3.27	53.2

Item No.	Nominal Size	Working Load Limit	Dimensions (mm)							N.W.
	mm		tonnes*	A	B	D	E	G	H	
8-808-08	8	1.2	31	8	9.5	21	19	54	13	0.1
8-808-10	10	2	36	10	11	26	23	65	16	0.1
8-808-11	11	2.7	43	11	13	30	27	75	19	0.2
8-808-13	13	3.3	47	13	16	33	30	85	20	0.3
8-808-16	16	5	61	16	19	43	39	107	27	0.7
8-808-19	19	7	72	19	22	50	46	126	33	1.0
8-808-22	22	9.5	86	22	26	58	53	148	38	1.7
8-808-26	26	12.5	96	26	28	68	60	166	44	2.4
8-808-28	28	15	111	28	32	74	68	190	46	3.4
8-808-32	32	18	121	32	36	82	76	210	54	4.8
8-808-36	36	21	134	36	38	92	84	232	59	6.5
8-808-38	38	30	146	38	45	99	92	254	60	8.7
8-808-45	45	40	178	47	51	127	106	313	73	17.5
8-808-50	50	55	197	53	57	146	122	347	83	24.2

★ Minimum Ultimate Load is 5 times the Working Load Limit.

Maximun Proof Load is 2 times the Working Load Limit.

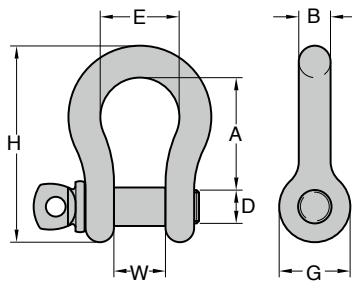

- Shackles are Type Approved by DNV & ABS.
- Shackles are forged alloy steel with alloy pin.
- Size and the Working Load Limit permanently shown on each shackle.
- All shackles with Batch Code which links to Test Certificate and quality traceability.
- 100% magnaflux crack detection during manufacturing.
- 20,000 cycle fatigue rated to 1.5 times Working Load Limit.

YOKE 8-807 Screw Pin Anchor Shackles meet the performance requirements of Federal Specification RR-C-271F, Type 4A, Grade B, Class 2.

Type Approval



Forged Alloy Anchor shackle

with Screw Pin

Item No.	Nominal Size	Working Load Limit	Dimensions (inch)							N.W.
	inch		tonnes*	A	B	D	E	G	H	W
8-807-08	5/16	1.2	1.22	0.31	0.37	0.83	0.75	2.13	0.47	0.2
8-807-10	3/8	2	1.42	0.39	0.43	1.02	0.91	2.56	0.63	0.2
8-807-11	7/16	2.7	1.70	0.43	0.51	1.18	1.06	2.95	0.75	0.4
8-807-13	1/2	3.3	1.85	0.52	0.63	1.30	1.18	3.34	0.79	0.7
8-807-16	5/8	5	2.40	0.63	0.75	1.77	1.53	4.21	1.06	1.3
8-807-19	3/4	7	2.83	0.75	0.87	1.97	1.81	4.96	1.30	2.2
8-807-22	7/8	9.5	3.39	0.87	1.02	2.28	2.09	5.82	1.50	3.3
8-807-26	1	12.5	3.78	1.02	1.10	2.68	2.36	6.53	1.73	5.1
8-807-28	1 1/8	15	4.37	1.10	1.26	2.91	2.68	7.48	1.81	7.0
8-807-32	1 1/4	18	4.76	1.26	1.42	3.22	2.99	8.26	2.12	9.7
8-807-36	1 3/8	21	5.28	1.42	1.50	3.62	3.31	9.13	2.32	13.2

Item No.	Nominal Size	Working Load Limit	Dimensions (mm)							N.W.
	mm		tonnes*	A	B	D	E	G	H	W
8-807-08	8	1.2	31	8	9.5	21	19	54	12	0.1
8-807-10	10	2	36	10	11	26	23	65	16	0.1
8-807-11	11	2.7	43	11	13	30	27	75	19	0.2
8-807-13	13	3.3	47	13	16	33	30	85	20	0.3
8-807-16	16	5	61	16	19	43	39	107	27	0.6
8-807-19	19	7	72	19	22	50	46	126	33	1.0
8-807-22	22	9.5	86	22	26	58	53	148	38	1.5
8-807-26	26	12.5	96	26	28	68	60	166	44	2.3
8-807-28	28	15	111	28	32	74	68	190	46	3.2
8-807-32	32	18	121	32	36	84	76	210	54	4.4
8-807-36	36	21	134	36	38	92	84	232	59	6.0

★ Minimum Ultimate Load is 5 times the Working Load Limit.
 Maximun Proof Load is 2 times the Working Load Limit.



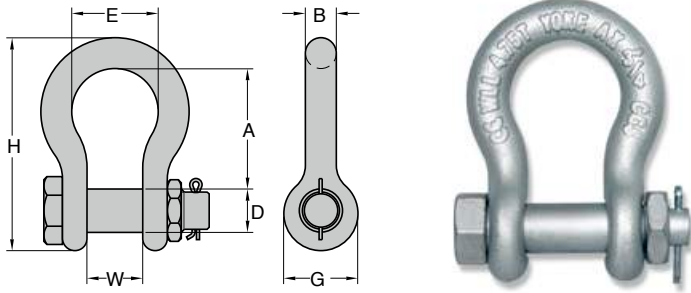

- Shackles are Type Approved by DNV & ABS.
- Shackles are **forged carbon steel** with alloy pin.
- Size and the Working Load Limit permanently shown on each shackle.
- All shackles with Batch Code which links to Test Certificate and quality traceability.
- 100% magnaflux crack detection during manufacturing.
- 20,000 cycle fatigue rated to 1.5 times Working Load Limit.

YOKE 8-838 Carbon Bolt Type Anchor Shackles meet the performance requirements of Federal Specification RR-C-271F, Type 4A, Grade A, Class 3.

Type Approval



Forged Anchor Shackle

with Bolt Pin. Carbon Steel

Item No.	Nominal Size	Working Load Limit	Dimensions (inch)							N.W.
	inch		tonnes*	A	B	D	E	G	H	W
8-838-08	5/16	0.75	1.22	0.31	0.37	0.82	0.75	2.13	0.47	0.2
8-838-10	3/8	1	1.42	0.39	0.43	1.02	0.91	2.56	0.63	0.2
8-838-11	7/16	1.5	1.70	0.43	0.51	1.18	1.06	2.95	0.75	0.4
8-838-13	1/2	2	1.85	0.52	0.63	1.30	1.18	3.34	0.79	0.9
8-838-16	5/8	3.25	2.40	0.63	0.75	1.70	1.50	4.17	1.06	1.5
8-838-19	3/4	4.75	2.83	0.75	0.87	1.97	1.81	5.04	1.30	2.2
8-838-22	7/8	6.5	3.39	0.87	1.02	2.28	2.09	5.91	1.50	3.7
8-838-26	1	8.5	3.78	1.02	1.10	2.68	2.40	6.57	1.73	5.3
8-838-28	1 1/8	9.5	4.37	1.10	1.26	2.91	2.68	7.52	1.81	7.5
8-838-32	1 1/4	12	4.76	1.26	1.42	3.30	2.99	8.07	2.12	10.6
8-838-36	1 3/8	13.5	5.28	1.42	1.50	3.62	3.31	9.13	2.32	14.3
8-838-38	1 1/2	17	5.57	1.50	1.77	3.90	3.62	10.00	2.36	19.4
8-838-45	1 3/4	25	7.00	1.85	2.00	5.00	4.17	12.32	2.87	38.5
8-838-50	2	35	7.76	2.09	2.24	5.75	4.80	13.66	3.27	53.2

Item No.	Nominal Size	Working Load Limit	Dimensions (mm)							N.W.
	mm		tonnes*	A	B	D	E	G	H	W
8-838-08	8	0.75	31	8	9.5	21	19	54	12	0.1
8-838-10	10	1	36	10	11	26	23	65	16	0.1
8-838-11	11	1.5	43	11	13	30	27	75	19	0.2
8-838-13	13	2	47	13	16	33	30	85	20	0.4
8-838-16	16	3.25	61	16	19	43	38	106	27	0.7
8-838-19	19	4.75	72	19	22	50	46	126	33	1.0
8-838-22	22	6.5	86	22	26	58	53	148	38	1.7
8-838-26	26	8.5	96	26	28	68	61	166	44	2.4
8-838-28	28	9.5	111	28	32	74	68	190	46	3.4
8-838-32	32	12	121	32	36	84	76	210	54	4.8
8-838-36	36	13.5	134	36	38	92	84	232	59	6.5
8-838-38	38	17	146	38	45	99	92	254	60	8.8
8-838-45	45	25	178	47	51	127	106	313	73	17.5
8-838-50	50	35	197	53	57	146	122	347	83	24.2

★ Minimum Ultimate Load is 6 times the Working Load Limit.
 Maximum Proof Load is 2 times the Working Load Limit.

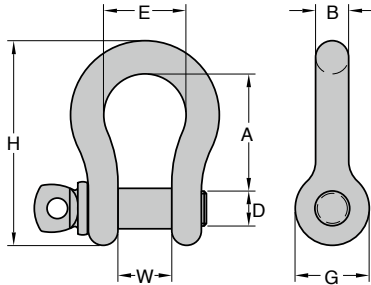

- Shackles are Type Approved by DNV & ABS.
- Shackles are **forged carbon steel** with alloy pin.
- Size and the Working Load Limit permanently shown on each shackle.
- All shackles with Batch Code which links to Test Certificate and quality traceability.
- 100% magnaflux crack detection during manufacturing.
- 20,000 cycle fatigue rated to 1.5 times Working Load Limit.

YOKE 8-837 Carbon Bolt Type Anchor Shackles meet the performance requirements of Federal Specification RR-C-271F, Type 4A, Grade A, Class 2.

Type Approval



Forged Anchor Shackle

with Screw Pin. Carbon Steel

Item No.	Nominal Size	Working Load Limit tonnes*	Dimensions (inch)							N.W.
	inch		A	B	D	E	G	H	W	lbs
8-837-05	3/16	0.3	0.87	0.2	0.25	0.69	0.57	1.48	0.38	0.05
8-837-06	1/4	0.5	1.10	0.26	0.32	0.80	0.63	1.85	0.47	0.1
8-837-08	5/16	0.75	1.22	0.31	0.37	0.82	0.75	2.13	0.47	0.2
8-837-10	3/8	1	1.42	0.39	0.43	1.02	0.91	2.56	0.63	0.2
8-837-11	7/16	1.5	1.70	0.43	0.51	1.18	1.06	2.95	0.75	0.4
8-837-13	1/2	2	1.85	0.52	0.63	1.30	1.18	3.34	0.79	0.7
8-837-16	5/8	3.25	2.40	0.63	0.75	1.70	1.50	4.17	1.06	1.3
8-837-19	3/4	4.75	2.83	0.75	0.87	1.96	1.81	5.04	1.30	2.2
8-837-22	7/8	6.5	3.39	0.87	1.02	2.28	2.08	5.91	1.50	3.3
8-837-26	1	8.5	3.78	1.02	1.10	2.68	2.67	6.57	1.73	5.1
8-837-28	1 1/8	9.5	4.37	1.10	1.26	2.91	2.68	7.52	1.81	7.0
8-837-32	1 1/4	12	4.76	1.26	1.42	3.30	2.99	8.07	2.12	9.9
8-837-36	1 3/8	13.5	5.28	1.42	1.50	3.62	3.30	9.13	2.32	13.9
8-837-38	1 1/2	17	5.75	1.50	1.77	3.90	3.62	10.00	2.36	17.8
8-837-45	1 3/4	25	7.00	1.85	2.00	5.00	4.17	12.32	2.87	35.9
8-837-50	2	35	7.76	2.09	2.24	5.75	4.80	13.66	3.27	51.0

Item No.	Nominal Size	Working Load Limit tonnes*	Dimensions (mm)							N.W.
	mm		A	B	D	E	G	H	W	kg
8-837-05	5	0.3	22	5	6	17	15	38	10	0.021
8-837-06	6	0.5	28	6.5	8	20	16	47	12	0.05
8-837-08	8	0.75	31	8	9.5	21	19	54	12	0.1
8-837-10	10	1	36	10	11	26	23	65	16	0.1
8-837-11	11	1.5	43	11	13	30	27	75	19	0.2
8-837-13	13	2	47	13	16	33	30	85	20	0.3
8-837-16	16	3.25	61	16	19	43	38	106	27	0.6
8-837-19	19	4.75	72	19	22	50	46	126	33	1.0
8-837-22	22	6.5	86	22	26	58	53	148	38	1.5
8-837-26	26	8.5	96	26	28	69	61	166	44	2.3
8-837-28	28	9.5	111	28	32	74	68	190	46	3.2
8-837-32	32	12	121	32	36	84	76	210	54	4.5
8-837-36	36	13.5	134	36	38	92	84	232	59	6.3
8-837-38	38	17	146	38	45	99	92	254	60	8.1
8-837-45	45	25	178	47	51	127	106	313	73	16.3
8-837-50	50	35	197	53	57	146	122	347	83	23.2

★ Minimum Ultimate Load is 6 times the Working Load Limit.
 Maximum Proof Load is 2 times the Working Load Limit.



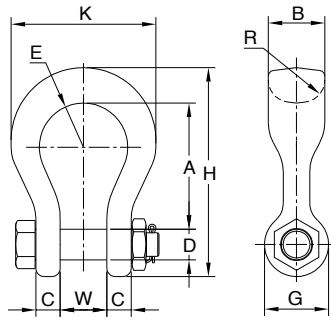

Fig. 1

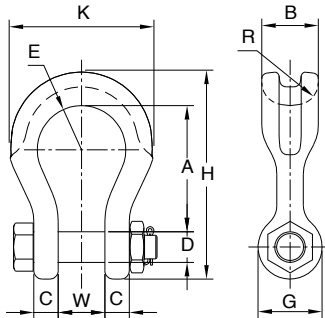

Fig. 2



- Shackles are forged alloy steel with alloy pin.
- Size and the Working Load Limit permanently shown on each shackle.
- All shackles with Batch Code which links to Test Certificate and quality traceability.
- 100% magnaflux crack detection during manufacturing.
- 20,000 cycle fatigue rated to 1.5 times Working Load Limit.

Forged Alloy Wide Body Shackle

with Bolt Pin

Item No.	Nominal Size	Working Load Limit	Dimensions (inch)										N.W.
			inch	tonnes*	A	B	C	D	E	G	H	K	
8-809-19	3/4	7	3.58	1.61	0.70	0.87	1.26	1.81	5.90	4.09	1.26	1.30	3.7
8-809-26	1	12.5	4.64	2.12	0.91	1.14	1.61	2.40	7.64	5.51	1.38	1.73	8.4
8-809-32	1 1/4	18	5.83	2.52	1.18	1.42	2.00	2.68	9.37	6.77	1.50	2.13	14.7
8-809-38	1 1/2	30	6.93	3.15	1.38	1.77	2.50	3.50	11.38	8.50	1.77	2.36	27.5

★ Minimum Ultimate Load is 5 times the Working Load Limit.

Maximun Proof Load is 2 times the Working Load Limit.

★ 8-809-19/-26 See Figure 1

★ 8-809-32/-38 See Figure 2

Item No.	Nominal Size	Working Load Limit	Dimensions (mm)										N.W.
			mm	tonnes*	A	B	C	D	E	G	H	K	
8-809-19	19	7	91	41	18	22	32	46	150	104	32	33	1.7
8-809-26	26	12.5	118	54	23	29	41	61	194	140	35	44	3.8
8-809-32	32	18	148	64	30	36	51	68	238	172	38	54	6.7
8-809-38	38	30	176	80	35	45	64	89	289	216	45	60	12.5

★ Minimum Ultimate Load is 5 times the Working Load Limit.

Maximun Proof Load is 2 times the Working Load Limit.

Forged Alloy Chain Shackle

with Bolt Pin

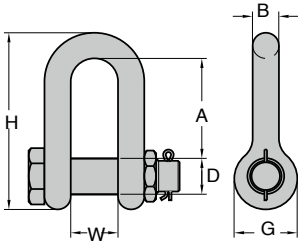

YOKE 8-805 Bolt Type Chain Shackles meet the performance requirements of Federal Specification RR-C-271F, Type 4B, Grade B, Class 3.

Type Approval



Type Approval

- Shackles are Type Approved by ABS.
- Shackles are forged alloy steel with alloy pin.
- Size and the Working Load Limit permanently shown on each shackle.
- All shackles with Batch Code which links to Test Certificate and quality traceability.
- 100% magnaflux crack detection during manufacturing.
- 20,000 cycle fatigue rated to 1.5 times Working Load Limit.

Item No.	Nominal Size	Working Load Limit tonnes*	Dimensions (mm)						N.W. kg
	inch		A	B	D	G	H	W	
8-805-16	5/8	5	60	16	19	38	106	27	0.6
8-805-19	3/4	7	71	19	22	46	126	33	1.0
8-805-22	7/8	9.5	87	22	26	53	148	38	1.6
8-805-26	1	12.5	95	26	28	60	166	44	2.4
8-805-28	1 1/8	15	108	28	32	68	190	46	3.3
8-805-32	1 1/4	18	119	32	36	76	210	52	4.6
8-805-36	1 3/8	21	133	36	38	84	232	57	6.2

- ★ Minimum Ultimate Load is 5 times the Working Load Limit.
- Maximun Proof Load is 2 times the Working Load Limit.

Forged Alloy Chain Shackle

with Screw Pin

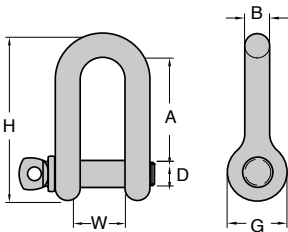

YOKE 8-804 Screw Type Chair Shackles meet the performance requirements of Federal Specification RR-C-271F, Type 4B, Grade B, Class 2.

Type Approval



Type Approval

- Shackles are Type Approved by DNV & ABS.
- Shackles are forged alloy steel with alloy pin.
- Size and the Working Load Limit permanently shown on each shackle.
- All shackles with Batch Code which links to Test Certificate and quality traceability.
- 100% magnaflux crack detection during manufacturing.
- 20,000 cycle fatigue rated to 1.5 times Working Load Limit.

Item No.	Nominal Size	Working Load Limit tonnes*	Dimensions (mm)						N.W. kg
	inch		A	B	D	G	H	W	
8-804-08	5/16	1.2	31	8	9.5	19	52	13	0.1
8-804-10	3/8	2	36	10	11	23	63	16	0.1
8-804-11	7/16	2.7	43	11	13	27	74	19	0.2
8-804-13	1/2	3.3	47	13	16	30	83	20	0.3
8-804-16	5/8	5	60	16	19	38	106	27	0.6
8-804-19	3/4	7	71	19	22	46	126	33	0.9
8-804-22	7/8	9.5	87	22	26	53	148	38	1.4
8-804-26	1	12.5	95	26	28	60	166	44	2.2
8-804-28	1 1/8	15	108	28	32	68	190	46	3.0
8-804-32	1 1/4	18	119	32	36	76	210	52	4.2
8-804-36	1 3/8	21	133	36	38	84	232	57	5.7

- ★ Minimum Ultimate Load is 5 times the Working Load Limit.
- Maximun Proof Load is 2 times the Working Load Limit.

Forged Chain Shackle

with Bolt Pin

- Shackles are Type Approved by ABS.
- Shackles are forged carbon steel with alloy pin.
- Size and the Working Load Limit permanently shown on each shackle.
- All shackles with Batch Code which links to Test Certificate and quality traceability.
- 100% magnaflux crack detection during manufacturing.
- 20,000 cycle fatigue rated to 1.5 times Working Load Limit.

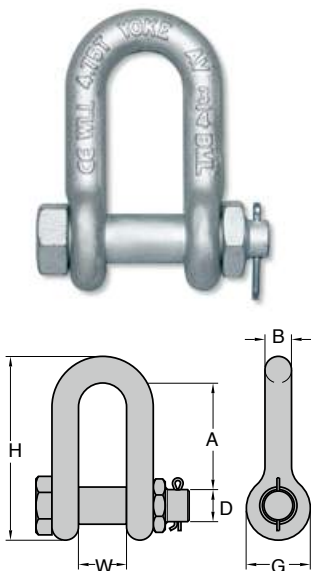

YOKE 8-835 Bolt Type Anchor Shackles meet the performance requirements of Federal Specification RR-C-271F, Type 4B, Grade A, Class 3.

Type Approval



Item No.	Nominal Size	Working Load Limit tonnes*	Dimensions (mm)						N.W. kg
	inch		A	B	D	G	H	W	
8-835-08	5/16	0.75	31	8	9.5	19	52	13	0.1
8-835-10	3/8	1	36	10	11	23	63	16	0.1
8-835-11	7/16	1.5	43	11	13	27	74	19	0.2
8-835-13	1/2	2	57	13	16	30	83	20	0.3
8-835-16	5/8	3.25	60	16	19	38	106	27	0.6
8-835-19	3/4	4.75	71	19	22	46	126	33	1.0
8-835-22	7/8	6.5	87	22	26	53	148	38	1.6
8-835-26	1	8.5	95	26	28	60	166	44	2.4
8-835-28	1 1/8	9.5	108	28	32	68	190	46	3.2
8-835-32	1 1/4	12	119	32	36	76	210	52	4.5
8-835-36	1 3/8	13.5	133	36	38	84	232	57	6.1

★ Minimum Ultimate Load is 6 times the Working Load Limit.
Maximum Proof Load is 2 times the Working Load Limit.

Forged Chain Shackle

with Screw Pin

- Shackles are Type Approved by ABS.
- Shackles are forged carbon steel with alloy pin.
- Size and the Working Load Limit permanently shown on each shackle.
- All shackles with Batch Code which links to Test Certificate and quality traceability.
- 100% magnaflux crack detection during manufacturing.
- 20,000 cycle fatigue rated to 1.5 times Working Load Limit.

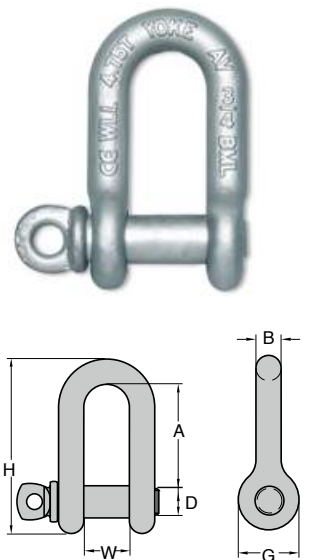

YOKE 8-834 Screw Pin Chain Shackles meet the performance requirements of Federal Specification RR-C-271F, Type 4B, Grade A, Class 2.

Type Approval



Item No.	Nominal Size	Working Load Limit tonnes*	Dimensions (mm)						N.W. kg
	inch		A	B	D	G	H	W	
8-834-08	5/16	0.75	31	8	9.5	19	52	13	0.1
8-834-10	3/8	1	36	10	11	23	63	16	0.1
8-834-11	7/16	1.5	43	11	13	27	74	19	0.2
8-834-13	1/2	2	57	13	16	30	83	20	0.3
8-834-16	5/8	3.25	60	16	19	38	106	27	0.6
8-834-19	3/4	4.75	71	19	22	46	126	33	1.0
8-834-22	7/8	6.5	87	22	26	53	148	38	1.5
8-834-26	1	8.5	95	26	28	60	166	44	2.2
8-834-28	1 1/8	9.5	108	28	32	68	190	46	3.0
8-834-32	1 1/4	12	119	32	36	76	210	52	4.2
8-834-36	1 3/8	13.5	133	36	38	84	232	57	5.7

★ Minimum Ultimate Load is 6 times the Working Load Limit.
Maximum Proof Load is 2 times the Working Load Limit.

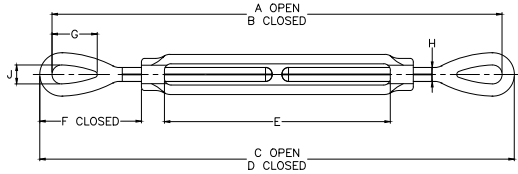

In accordance with Federal Specification FF-T-791b, TYPE1, Form 1, CLASS 4, and ASTM F-1145

Turnbuckles

- Forged steel with hot dipped galvanized finish.
- YOKE turnbuckles are manufactured in accordance with all requirements of ASME B30.26 and designed to fulfill other safety requirements that are not addressed by ASME B30.26.
- YOKE turnbuckles are fitted with locknuts as standard.
- Maximum Proof Load is 2.5 times WLL.
- Ultimate load is 5 times the WLL.
- Fatigue Rated to 20,000 cycles at 1.5 times the WLL.
- Turnbuckles are recommended for straight or in-line pull only.
- End fittings are Quenched and Tempered at 400°C; bodies are heat treated by normalizing.
- Turnbuckle eyes are enlarged to ease the operation and to minimize stress in the eye.

Eye and Eye Turnbuckle by Imperial

Item No.	Thread Dia. & Take up	Working Load Limit	Dimension(inch)									N.W lbs
			A	B	C	D	E	F	G	H	J	
			Open	Closed	Open	Closed		Closed				
8-751-0604	1/4 x 4	0.23	11.93	7.95	12.36	8.39	4.06	1.77	0.83	0.24	0.35	0.29
8-751-0804	5/16 x 4-1/2	0.36	13.94	9.41	14.49	9.96	4.57	2.20	0.94	0.31	0.43	0.48
8-751-1006	3/8 x 6	0.54	17.56	11.57	18.23	12.24	6.10	2.48	1.14	0.39	0.55	1.19
8-751-1306	1/2 x 6	1	19.92	13.94	20.83	14.80	6.02	3.54	1.42	0.51	0.71	1.72
8-751-1309	1/2 x 9	1	25.20	16.93	26.10	17.83	9.37	3.54	1.42	0.51	0.71	2.20
8-751-1312	1/2 x 12	1	32.24	20.24	33.11	21.10	12.36	3.54	1.42	0.51	0.71	2.62
8-751-1606	5/8 x 6	1.59	21.73	15.71	22.72	16.73	6.02	4.33	1.81	0.63	0.87	2.75
8-751-1609	5/8 x 9	1.59	26.93	18.70	27.91	19.76	9.41	4.33	1.81	0.63	0.87	3.30
8-751-1612	5/8 x 12	1.59	34.06	22.05	35.08	23.07	12.40	4.33	1.81	0.63	0.87	4.11
8-751-1618	5/8 x 18	1.59	41.65	28.03	42.64	29.06	18.43	4.33	1.81	0.63	0.87	6.60
8-751-1906	3/4 x 6	2.36	23.23	17.24	24.49	18.50	6.14	5.12	2.09	0.75	0.98	4.20
8-751-1909	3/4 x 9	2.36	27.56	20.24	28.90	21.50	9.61	5.12	2.09	0.75	0.98	5.17
8-751-1912	3/4 x 12	2.36	35.63	23.62	36.89	24.88	12.60	5.08	2.09	0.75	0.98	6.12
8-751-1918	3/4 x 18	2.36	47.64	29.65	48.90	30.91	18.54	5.12	2.09	0.75	0.98	7.81
8-751-2212	7/8 x 12	3.27	36.69	24.69	38.19	26.18	12.17	5.79	2.40	0.87	1.26	8.82
8-751-2218	7/8 x 18	3.27	49.17	31.18	50.67	32.68	18.62	5.79	2.40	0.87	1.26	11.48
8-751-2606	1 x 6	4.54	26.22	20.24	27.99	22.01	6.18	6.50	2.99	0.98	1.42	9.59
8-751-2612	1 x 12	4.54	38.23	26.22	40.00	27.99	12.17	6.50	2.99	0.98	1.42	12.94
8-751-2618	1 x 18	4.54	50.24	32.24	52.01	34.02	18.19	6.50	2.99	0.98	1.42	16.28
8-751-2624	1 x 24	4.54	62.83	38.86	64.61	40.59	24.84	6.46	2.99	0.98	1.42	20.11
8-751-3212	1-1/4 x 12	6.9	42.13	30.16	44.37	32.36	12.05	8.50	3.58	1.26	1.81	19.82
8-751-3218	1-1/4 x 18	6.9	54.13	36.14	56.38	38.39	18.07	8.50	3.58	1.26	1.81	23.76
8-751-3224	1-1/4 x 24	6.9	66.69	42.72	68.94	44.92	24.61	8.50	3.58	1.26	1.81	27.72
8-751-3812	1-1/2 x 12	9.71	44.25	32.24	46.73	34.72	12.32	9.45	4.09	1.50	2.13	28.60
8-751-3818	1-1/2 x 18	9.71	56.22	38.23	58.74	40.75	18.31	9.45	4.09	1.50	2.13	33.88
8-751-3824	1-1/2 x 24	9.71	68.86	44.84	71.38	47.36	24.92	9.45	4.09	1.50	2.13	39.38
8-751-4518	1-3/4 x 18	12.7	57.36	39.37	60.39	42.36	18.39	9.96	4.65	1.77	2.40	50.60
8-751-4524	1-3/4 x 24	12.7	69.37	45.39	72.36	48.39	24.37	9.96	4.65	1.77	2.40	58.08
8-751-5024	2 x 24	16.8	75.67	51.69	79.17	55.20	24.49	13.03	5.83	2.01	2.68	83.38
8-751-6424	2-1/2 x 24	27.2	79.17	55.20	83.19	59.17	24.61	13.78	6.50	2.52	3.11	148.28
8-751-7024	2-3/4 x 24	34	81.34	57.32	85.83	61.85	24.65	15.08	7.01	2.76	3.27	174.02

Turnbuckles

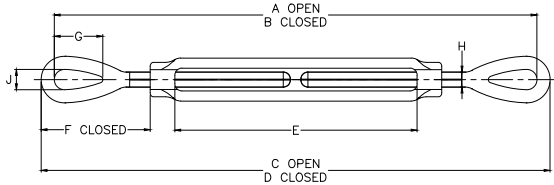

In accordance with Federal Specification FF-T-791b, TYPE1, Form 1, CLASS 4, and ASTM F-1145

- Forged steel with hot dipped galvanized finish.
- YOKE turnbuckles are manufactured in accordance with all requirements of ASME B30.26 and designed to fulfill other safety requirements that are not addressed by ASME B30.26.
- YOKE turnbuckles are fitted with locknuts as standard.
- Maximum Proof Load is 2.5 times WLL.
- Ultimate load is 5 times the WLL.
- Fatigue Rated to 20,000 cycles at 1.5 times the WLL.
- Turnbuckles are recommended for straight or in-line pull only.
- End fittings are Quenched and Tempered at 400°C; bodies are heat treated by normalizing.
- Turnbuckle eyes are enlarged to ease the operation and to minimize stress in the eye.

Eye and Eye Turnbuckle by Metric

Item No.	Thread Dia. & Take up		Working Load Limit		Dimension(mm)							N.W kg
	mm	tonnes*	A Open	B Closed	C Open	D Closed	E	F Closed	G	H	J	
8-751-0604	6.35 x 102	0.23	303	202	314	213	103	45	21	6	9	0.13
8-751-0804	7.94 x 114	0.36	354	239	368	253	116	56	24	8	11	0.22
8-751-1006	9.53 x 152	0.54	446	294	463	311	155	63	29	10	14	0.54
8-751-1306	12.7 x 152	1	506	354	529	376	153	90	36	13	18	0.78
8-751-1309	12.7 x 229	1	640	430	663	453	238	90	36	13	18	1
8-751-1312	12.7 x 305	1	819	514	841	536	314	90	36	13	18	1.19
8-751-1606	15.9 x 152	1.59	552	399	577	425	153	110	46	16	22	1.25
8-751-1609	15.9 x 229	1.59	684	475	709	502	239	110	46	16	22	1.5
8-751-1612	15.9 x 305	1.59	865	560	891	586	315	110	46	16	22	1.87
8-751-1618	15.9 x 457	1.59	1058	712	1083	738	468	110	46	16	22	3
8-751-1906	19.1 x 152	2.36	590	438	622	470	156	130	53	19	25	1.91
8-751-1909	19.1 x 229	2.36	700	514	734	546	244	130	53	19	25	2.35
8-751-1912	19.1 x 305	2.36	905	600	937	632	320	129	53	19	25	2.78
8-751-1918	19.1 x 457	2.36	1210	753	1242	785	471	130	53	19	25	3.55
8-751-2212	22.2 x 305	3.27	932	627	970	665	309	147	61	22	32	4.01
8-751-2218	22.2 x 457	3.27	1249	792	1287	830	473	147	61	22	32	5.22
8-751-2606	25.4 x 152	4.54	666	514	711	559	157	165	76	25	36	4.36
8-751-2612	25.4 x 305	4.54	971	666	1016	711	309	165	76	25	36	5.88
8-751-2618	25.4 x 457	4.54	1276	819	1321	864	462	165	76	25	36	7.4
8-751-2624	25.4 x 610	4.54	1596	987	1641	1031	631	164	76	25	36	9.14
8-751-3212	31.8 x 305	6.9	1070	766	1127	822	306	216	91	32	46	9.01
8-751-3218	31.8 x 457	6.9	1375	918	1432	975	459	216	91	32	46	10.8
8-751-3224	31.8 x 610	6.9	1694	1085	1751	1141	625	216	91	32	46	12.6
8-751-3812	38.1 x 305	9.71	1124	819	1187	882	313	240	104	38	54	13
8-751-3818	38.1 x 457	9.71	1428	971	1492	1035	465	240	104	38	54	15.4
8-751-3824	38.1 x 610	9.71	1749	1139	1813	1203	633	240	104	38	54	17.9
8-751-4518	44.5 x 457	12.7	1457	1000	1534	1076	467	253	118	45	61	23
8-751-4524	44.5 x 610	12.7	1762	1153	1838	1229	619	253	118	45	61	26.4
8-751-5024	51.0 x 610	16.8	1922	1313	2011	1402	622	331	148	51	68	37.9
8-751-6424	63.5 x 610	27.2	2011	1402	2113	1503	625	350	165	64	79	67.4
8-751-7024	70.0 x 610	34	2066	1456	2180	1571	626	383	178	70	83	79.1

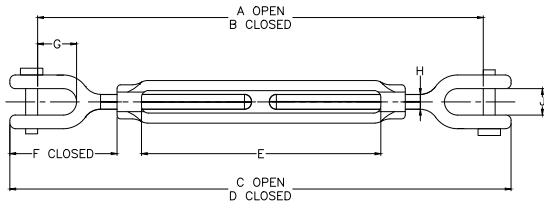

In accordance with Federal Specification FF-T-791b, TYPE1, Form 1, CLASS 7, and ASTM F-1145

Turnbuckle

- Forged steel with hot dipped galvanized finish.
- YOKE turnbuckles are manufactured in accordance with all requirements of ASME B30.26 and designed to fulfill other safety requirements that are not addressed by ASME B30.26.
- YOKE turnbuckles are fitted with locknuts as standard.
- All YOKE jaw end turnbuckles are fitted with bolt and nut for additional safety as standard.
- Maximum Proof Load is 2.5 times WLL.
- Ultimate load is 5 times the WLL.
- Fatigue Rated to 20,000 cycles at 1.5 times the WLL.
- Turnbuckles are recommended for straight or in-line pull only.
- End fittings are Quenched and Tempered at 400°C; bodies are heat treated by normalizing.
- Turnbuckle jaws are supplied with bolt and nut for the best security of fittings.

Jaw and Jaw Turnbuckle by Imperial

Item No.	Thread Dia. & Take up inch	Working Load Limit tonnes*	Dimension(inch)									N.W lbs
			A	B	C	D	E	F	G	H	J	
			Open	Closed	Open	Closed		Closed				
8-752-0604	1/4 x 4	0.23	11.18	7.20	12.17	8.19	4.06	1.65	0.63	0.24	0.43	0.37
8-752-0804	5/16 x 4-1/2	0.36	13.07	8.58	14.13	9.61	4.57	2.01	0.87	0.31	0.51	0.55
8-752-1006	3/8 x 6	0.54	16.26	10.24	17.52	11.50	6.10	2.13	0.87	0.39	0.55	0.86
8-752-1306	1/2 x 6	1	18.66	12.64	20.16	14.13	6.02	3.23	1.06	0.51	0.63	1.83
8-752-1309	1/2 x 9	1	24.92	15.94	26.42	17.44	9.37	3.19	1.06	0.51	0.63	2.29
8-752-1312	1/2 x 12	1	30.94	18.94	32.44	20.43	12.36	3.19	1.06	0.51	0.63	2.71
8-752-1606	5/8 x 6	1.59	19.72	13.74	21.81	15.83	6.02	3.90	1.34	0.63	0.79	3.21
8-752-1609	5/8 x 9	1.59	26.06	17.09	28.15	19.17	9.41	3.90	1.34	0.63	0.79	3.94
8-752-1612	5/8 x 12	1.59	32.09	20.08	34.17	22.17	12.40	3.90	1.34	0.63	0.79	4.58
8-752-1618	5/8 x 18	1.59	43.35	26.73	45.16	28.54	18.43	3.90	1.54	0.63	0.79	7.26
8-752-1906	3/4 x 6	2.36	21.10	15.08	23.66	17.68	6.14	4.72	1.54	0.75	0.98	4.80
8-752-1909	3/4 x 9	2.36	27.48	18.50	30.08	21.06	9.61	4.69	1.54	0.75	0.98	5.83
8-752-1912	3/4 x 12	2.36	33.50	21.50	36.06	24.09	12.60	4.69	1.54	0.75	0.98	6.71
8-752-1918	3/4 x 18	2.36	45.47	27.48	48.07	30.08	18.54	4.72	1.54	0.75	0.98	8.43
8-752-2212	7/8 x 12	3.27	34.65	22.64	37.64	25.63	12.17	5.51	1.77	0.87	1.18	9.35
8-752-2218	7/8 x 18	3.27	47.13	29.13	50.08	32.09	18.62	5.51	1.77	0.87	1.18	11.75
8-752-2606	1 x 6	4.54	23.82	17.83	27.17	21.18	6.18	6.10	2.05	0.98	1.34	10.43
8-752-2612	1 x 12	4.54	35.83	23.82	39.17	27.17	12.17	6.10	2.05	0.98	1.34	13.75
8-752-2618	1 x 18	4.54	47.83	29.80	51.18	33.19	18.19	6.10	2.05	0.98	1.34	17.09
8-752-2624	1 x 24	4.54	60.43	36.42	63.78	39.76	24.84	6.06	2.05	0.98	1.34	20.92
8-752-3212	1-1/4 x 12	6.9	39.37	27.36	43.58	31.57	12.05	8.07	2.83	1.26	1.85	21.87
8-752-3218	1-1/4 x 18	6.9	51.38	33.39	55.59	37.60	18.07	8.07	2.83	1.26	1.85	25.74
8-752-3224	1-1/4 x 24	6.9	63.94	39.92	68.15	44.13	24.61	8.07	2.83	1.26	1.85	29.70
8-752-3812	1-1/2 x 12	9.71	40.75	28.78	45.67	33.66	12.32	8.94	2.80	1.50	1.85	32.56
8-752-3818	1-1/2 x 18	9.71	52.76	34.76	57.68	39.69	18.31	8.94	2.80	1.50	2.05	37.84
8-752-3824	1-1/2 x 24	9.71	65.39	41.38	70.31	46.30	24.92	8.94	2.80	1.50	2.05	43.34
8-752-4518	1-3/4 x 18	12.7	53.35	35.35	59.17	41.14	18.39	9.37	3.35	1.77	2.60	53.46
8-752-4524	1-3/4 x 24	12.7	65.35	41.34	71.14	47.17	24.37	9.37	3.35	1.77	2.60	60.94
8-752-5024	2 x 24	16.8	69.65	45.63	76.73	52.72	24.49	11.81	3.74	2.01	2.64	96.14
8-752-6424	2-1/2 x 24	27.2	72.95	48.98	82.17	58.19	24.61	13.27	4.45	2.99	3.07	166.98
8-752-7024	2-3/4 x 24	34	74.76	50.75	85.51	61.50	24.65	14.92	4.17	3.54	3.70	198.22

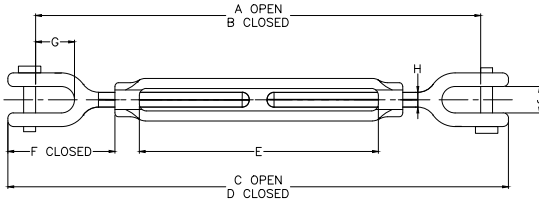

In accordance with Federal Specification FF-T-791b, TYPE1, Form 1, CLASS 7, and ASTM F-1145

Turnbuckle

- Forged steel with hot dipped galvanized finish.
- YOKE turnbuckles are manufactured in accordance with all requirements of ASME B30.26 and designed to fulfill other safety requirements that are not addressed by ASME B30.26.
- YOKE turnbuckles are fitted with locknuts as standard.
- All YOKE jaw end turnbuckles are fitted with bolt and nut for additional safety as standard.
- Maximum Proof Load is 2.5 times WLL.
- Ultimate load is 5 times the WLL.
- Fatigue Rated to 20,000 cycles at 1.5 times the WLL.
- Turnbuckles are recommended for straight or in-line pull only.
- End fittings are Quenched and Tempered at 400°C; bodies are heat treated by normalizing.
- Turnbuckle jaws are supplied with bolt and nut for the best security of fittings.

Jaw and Jaw Turnbuckle by Metric

Item No.	Thread Dia. & Take up mm	Working Load Limit tonnes*	Dimension(mm)									N.W kg
			A	B	C	D	E	F	G	H	J	
			Open	Closed	Open	Closed		Closed				
8-752-0604	6.35 x 102	0.23	284	183	309	208	103	42	16	6	11	0.17
8-752-0804	7.94 x 114	0.36	332	218	359	244	116	51	22	8	13	0.25
8-752-1006	9.53 x 152	0.54	413	260	445	292	155	54	22	10	14	0.39
8-752-1306	12.7 x 152	1	474	321	512	359	153	82	27	13	16	0.83
8-752-1309	12.7 x 229	1	633	405	671	443	238	81	27	13	16	1.04
8-752-1312	12.7 x 305	1	786	481	824	519	314	81	27	13	16	1.23
8-752-1606	15.9 x 152	1.59	501	349	554	402	153	99	34	16	20	1.46
8-752-1609	15.9 x 229	1.59	662	434	715	487	239	99	34	16	20	1.79
8-752-1612	15.9 x 305	1.59	815	510	868	563	315	99	34	16	20	2.08
8-752-1618	15.9 x 457	1.59	1101	679	1147	725	468	99	39	16	20	3.3
8-752-1906	19.1 x 152	2.36	536	383	601	449	156	120	39	19	25	2.18
8-752-1909	19.1 x 229	2.36	698	470	764	535	244	119	39	19	25	2.65
8-752-1912	19.1 x 305	2.36	851	546	916	612	320	119	39	19	25	3.05
8-752-1918	19.1 x 457	2.36	1155	698	1221	764	471	120	39	19	25	3.83
8-752-2212	22.2 x 305	3.27	880	575	956	651	309	140	45	22	30	4.25
8-752-2218	22.2 x 457	3.27	1197	740	1272	815	473	140	45	22	30	5.34
8-752-2606	25.4 x 152	4.54	605	453	690	538	157	155	52	25	34	4.74
8-752-2612	25.4 x 305	4.54	910	605	995	690	309	155	52	25	34	6.25
8-752-2618	25.4 x 457	4.54	1215	757	1300	843	462	155	52	25	34	7.77
8-752-2624	25.4 x 610	4.54	1535	925	1620	1010	631	154	52	25	34	9.51
8-752-3212	31.8 x 305	6.9	1000	695	1107	802	306	205	72	32	47	9.94
8-752-3218	31.8 x 457	6.9	1305	848	1412	955	459	205	72	32	47	11.7
8-752-3224	31.8 x 610	6.9	1624	1014	1731	1121	625	205	72	32	47	13.5
8-752-3812	38.1 x 305	9.71	1035	731	1160	855	313	227	71	38	47	14.8
8-752-3818	38.1 x 457	9.71	1340	883	1465	1008	465	227	71	38	52	17.2
8-752-3824	38.1 x 610	9.71	1661	1051	1786	1176	633	227	71	38	52	19.7
8-752-4518	44.5 x 457	12.7	1355	898	1503	1045	467	238	85	45	66	24.3
8-752-4524	44.5 x 610	12.7	1660	1050	1807	1198	619	238	85	45	66	27.7
8-752-5024	51.0 x 610	16.8	1769	1159	1949	1339	622	300	95	51	67	43.7
8-752-6424	63.5 x 610	27.2	1853	1244	2087	1478	625	337	113	76	78	75.9
8-752-7024	70.0 x 610	34	1899	1289	2172	1562	626	379	106	90	94	90.1

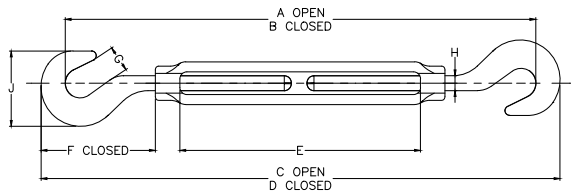

In accordance with Federal Specification FF-T-791b, TYPE1, Form 1, CLASS 5, and ASTM F-1145

Turnbuckles

- Forged steel with hot dipped galvanized finish.
- YOKE turnbuckles are manufactured in accordance with all requirements of ASME B30.26 and designed to fulfill other safety requirements that are not addressed by ASME B30.26.
- YOKE turnbuckles are fitted with locknuts as standard.
- Maximum Proof Load is 2.5 times WLL.
- Ultimate load is 5 times the WLL.
- Fatigue Rated to 20,000 cycles at 1.5 times the WLL.
- Turnbuckles are recommended for straight or in-line pull only.
- End fittings are Quenched and Tempered at 400°C; bodies are heat treated by normalizing.
- The cross sectional area of hooks is designed to be larger for better strength and fatigue properties.

Hook and Hook Turnbuckle by Imperial

Item No.	Thread Dia. & Take up	Working Load Limit	Dimension(inch)									N.W lbs
			A Open	B Closed	C Open	D Closed	E	F Closed	G	H	J	
8-753-0604	1/4 x 4	0.18	9.80	7.36	12.20	8.19	4.06	1.65	0.43	0.24	1.26	0.33
8-753-0804	5/16 x 4-1/2	0.32	11.57	8.58	14.09	9.57	4.57	2.01	0.51	0.31	1.50	0.53
8-753-1006	3/8 x 6	0.45	15.24	10.63	17.83	11.85	6.10	2.28	0.55	0.39	1.77	0.84
8-753-1306	1/2 x 6	0.68	17.99	13.19	20.75	14.76	6.02	3.54	0.67	0.51	2.28	1.87
8-753-1309	1/2 x 9	0.68	24.13	16.34	26.89	17.91	9.37	3.54	0.67	0.51	2.28	2.31
8-753-1312	1/2 x 12	0.68	30.28	19.49	33.03	21.06	12.36	3.50	0.67	0.51	2.28	2.77
8-753-1606	5/8 x 6	1.02	19.49	14.49	22.52	16.50	6.02	4.25	0.91	0.63	2.80	3.21
8-753-1609	5/8 x 9	1.02	25.67	17.64	28.70	19.69	9.41	4.21	0.91	0.63	2.80	3.74
8-753-1612	5/8 x 12	1.02	31.85	20.83	34.84	22.83	12.40	4.21	0.91	0.63	2.80	4.58
8-753-1618	5/8 x 18	1.02	44.21	27.17	47.17	29.17	18.43	4.17	0.91	0.63	2.80	5.50
8-753-1906	3/4 x 6	1.36	21.18	15.98	24.41	18.39	6.14	5.08	0.98	0.75	3.35	4.20
8-753-1909	3/4 x 9	1.36	27.40	19.17	30.63	21.61	9.61	5.04	0.98	0.75	3.35	5.28
8-753-1912	3/4 x 12	1.36	33.58	22.36	36.81	24.80	12.60	5.04	0.98	0.75	3.35	6.91
8-753-1918	3/4 x 18	1.36	45.59	28.39	48.82	30.79	18.54	5.08	0.98	0.75	3.35	8.62
8-753-2212	7/8 x 12	1.81	34.88	23.50	38.27	26.26	12.17	5.83	1.14	0.87	3.78	9.83
8-753-2218	7/8 x 18	1.81	47.64	29.92	51.38	32.68	18.31	5.79	1.14	0.87	3.78	11.66
8-753-2606	1 x 6	2.27	24.80	19.13	27.56	21.89	6.02	6.57	1.26	0.98	4.25	9.90
8-753-2612	1 x 12	2.27	36.57	25.08	40.12	28.11	12.17	6.57	1.26	0.98	4.25	14.74
8-753-2618	1 x 18	2.27	50.16	32.68	52.56	34.65	18.35	6.54	1.26	0.98	4.25	19.80
8-753-2624	1 x 24	2.27	63.78	40.16	64.96	40.94	24.41	6.57	1.26	0.98	4.25	25.30

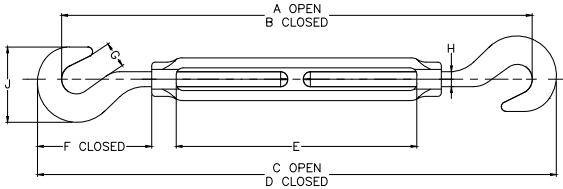

In accordance with Federal Specification FF-T-791b, TYPE1, Form 1, CLASS 5, and ASTM F-1145

Turnbuckles

- Forged steel with hot dipped galvanized finish.
- YOKE turnbuckles are manufactured in accordance with all requirements of ASME B30.26 and designed to fulfill other safety requirements that are not addressed by ASME B30.26.
- YOKE turnbuckles are fitted with locknuts as standard.
- Maximum Proof Load is 2.5 times WLL.
- Ultimate load is 5 times the WLL.
- Fatigue Rated to 20,000 cycles at 1.5 times the WLL.
- Turnbuckles are recommended for straight or in-line pull only.
- End fittings are Quenched and Tempered at 400°C; bodies are heat treated by normalizing.
- The cross sectional area of hooks is designed to be larger for better strength and fatigue properties.

Hook and Hook Turnbuckle by Metric

Item No.	Thread Dia. & Take up	Working Load Limit	Dimension(mm)									N.W kg
			A	B	C	D	E	F	G	H	J	
	mm	tonnes*	Open	Closed	Open	Closed		Closed				
8-753-0604	6.35 x 102	0.18	249	187	310	208	103	42	11	6	32	0.15
8-753-0804	7.94 x 114	0.32	294	218	358	243	116	51	13	8	38	0.24
8-753-1006	9.53 x 152	0.45	387	270	453	301	155	58	14	10	45	0.38
8-753-1306	12.7 x 152	0.68	457	335	527	375	153	90	17	13	58	0.85
8-753-1309	12.7 x 229	0.68	613	415	683	455	238	90	17	13	58	1.05
8-753-1312	12.7 x 305	0.68	769	495	839	535	314	89	17	13	58	1.26
8-753-1606	15.9 x 152	1.02	495	368	572	419	153	108	23	16	71	1.46
8-753-1609	15.9 x 229	1.02	652	448	729	500	239	107	23	16	71	1.7
8-753-1612	15.9 x 305	1.02	809	529	885	580	315	107	23	16	71	2.08
8-753-1618	15.9 x 457	1.02	1123	690	1198	741	468	106	23	16	71	2.5
8-753-1906	19.1 x 152	1.36	538	406	620	467	156	129	25	19	85	1.91
8-753-1909	19.1 x 229	1.36	696	487	778	549	244	128	25	19	85	2.4
8-753-1912	19.1 x 305	1.36	853	568	935	630	320	128	25	19	85	3.14
8-753-1918	19.1 x 457	1.36	1158	721	1240	782	471	129	25	19	85	3.92
8-753-2212	22.2 x 305	1.81	886	597	972	667	309	148	29	22	96	4.47
8-753-2218	22.2 x 457	1.81	1210	760	1305	830	465	147	29	22	96	5.3
8-753-2606	25.4 x 152	2.27	630	486	700	556	153	167	32	25	108	4.5
8-753-2612	25.4 x 305	2.27	929	637	1019	714	309	167	32	25	108	6.7
8-753-2618	25.4 x 457	2.27	1274	830	1335	880	466	166	32	25	108	9
8-753-2624	25.4 x 610	2.27	1620	1020	1650	1040	620	167	32	25	108	11.5

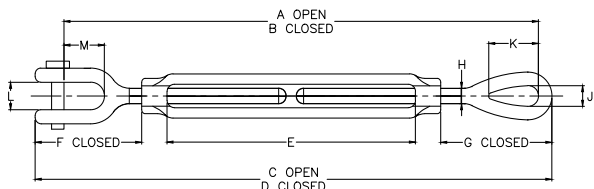

In accordance with Federal Specification FF-T-791b, TYPE1, Form 1, CLASS 8, and ASTM F-1145

Turnbuckle

- Forged steel with hot dipped galvanized finish.
- YOKE turnbuckles are manufactured in accordance with all requirements of ASME B30.26 and designed to fulfill other safety requirements that are not addressed by ASME B30.26.
- YOKE turnbuckles are fitted with locknuts as standard.
- All YOKE jaw end turnbuckles are fitted with bolt and nut for additional safety as standard.
- Maximum Proof Load is 2.5 times WLL.
- Ultimate load is 5 times the WLL.
- Fatigue Rated to 20,000 cycles at 1.5 times the WLL.
- Turnbuckles are recommended for straight or in-line pull only.
- End fittings are Quenched and Tempered at 400°C; bodies are heat treated by normalizing.
- Turnbuckle eyes are enlarged to ease the operation and to minimize stress in the eye.
- Turnbuckle jaws are supplied with bolt and nut for the best security of fittings.

Jaw and Eye Turnbuckle by Imperial

Item No.	Thread Dia. & Take up inch	Working Load Limit tonnes*	Dimension(inch)												N.W lbs
			A Open	B Closed	C Open	D Closed	E	F Closed	G Closed	H	J	K	L	M	
8-754-0604	1/4 x 4	0.23	11.57	7.56	12.28	8.27	4.06	1.65	1.77	0.24	0.35	0.83	0.43	0.63	0.33
8-754-0804	5/16 x 4-1/2	0.36	13.50	8.98	14.29	9.80	4.57	2.01	2.20	0.31	0.43	0.94	0.51	0.87	0.53
8-754-1006	3/8 x 6	0.54	16.89	10.91	17.87	11.85	6.10	2.13	2.48	0.39	0.55	1.14	0.55	0.87	0.79
8-754-1306	1/2 x 6	1	19.29	13.31	20.47	14.49	6.02	3.23	3.54	0.51	0.71	1.42	0.63	1.06	1.76
8-754-1309	1/2 x 9	1	25.59	16.57	26.77	17.76	9.37	3.19	3.54	0.51	0.71	1.42	0.63	1.06	2.24
8-754-1312	1/2 x 12	1	31.57	19.57	32.76	20.79	12.36	3.19	3.54	0.51	0.71	1.42	0.63	1.06	2.66
8-754-1606	5/8 x 6	1.59	20.75	14.72	22.28	16.26	6.02	3.90	4.33	0.63	0.87	1.81	0.79	1.34	2.97
8-754-1609	5/8 x 9	1.59	27.09	18.07	28.62	19.61	9.41	3.90	4.33	0.63	0.87	1.81	0.79	1.34	3.72
8-754-1612	5/8 x 12	1.59	33.07	21.06	34.61	22.60	12.40	3.90	4.33	0.63	0.87	1.81	0.79	1.34	4.33
8-754-1618	5/8 x 18	1.59	42.60	27.05	44.02	28.58	18.43	3.90	4.33	0.63	0.87	1.81	0.79	1.34	5.61
8-754-1906	3/4 x 6	2.36	22.17	16.18	24.09	18.07	6.14	4.72	5.12	0.75	0.98	2.09	0.98	1.54	4.51
8-754-1909	3/4 x 9	2.36	28.58	19.57	30.47	21.50	9.61	4.69	5.08	0.75	0.98	2.09	0.98	1.54	5.54
8-754-1912	3/4 x 12	2.36	34.57	22.56	36.50	24.49	12.60	4.69	5.08	0.75	0.98	2.09	0.98	1.54	6.40
8-754-1918	3/4 x 18	2.36	46.57	28.58	48.50	30.47	18.54	4.72	5.12	0.75	0.98	2.09	0.98	1.54	8.12
8-754-2212	7/8 x 12	3.27	33.66	23.66	37.91	25.91	12.17	5.51	5.79	0.87	1.26	2.40	1.18	1.77	9.09
8-754-2218	7/8 x 18	3.27	45.63	30.16	50.39	32.36	18.62	5.51	5.79	0.87	1.26	2.40	1.18	1.77	11.62
8-754-2606	1 x 6	4.54	25.04	19.02	27.60	21.57	6.18	6.10	6.50	0.98	1.42	2.99	1.34	2.05	10.01
8-754-2612	1 x 12	4.54	35.35	25.04	39.61	27.60	12.17	6.10	6.50	0.98	1.42	2.99	1.34	2.05	13.33
8-754-2618	1 x 18	4.54	47.32	31.02	51.57	33.58	18.19	6.10	6.50	0.98	1.42	2.99	1.34	2.05	16.68
8-754-2624	1 x 24	4.54	59.41	37.64	64.17	40.20	24.84	6.06	6.46	0.98	1.42	2.99	1.34	2.05	20.53
8-754-3212	1-1/4 x 12	6.9	37.64	28.74	43.98	31.97	12.05	8.07	8.50	1.26	1.81	3.58	1.85	2.83	20.86
8-754-3218	1-1/4 x 18	6.9	49.76	34.76	55.98	37.99	18.07	8.07	8.50	1.26	1.81	3.58	1.85	2.83	24.86
8-754-3224	1-1/4 x 24	6.9	61.61	41.34	68.54	44.53	24.61	8.07	8.50	1.26	1.81	3.58	1.85	2.83	28.82
8-754-3812	1-1/2 x 12	9.71	39.06	30.51	46.22	34.21	12.32	8.94	9.45	1.50	2.13	4.09	2.05	2.80	30.58
8-754-3818	1-1/2 x 18	9.71	51.02	36.50	58.23	40.20	18.31	8.94	9.45	1.50	2.13	4.09	2.05	2.80	35.86
8-754-3824	1-1/2 x 24	9.71	63.03	43.11	70.83	46.81	24.92	8.94	9.45	1.50	2.13	4.09	2.05	2.80	41.36
8-754-4518	1-3/4 x 18	12.7	54.02	37.36	59.76	41.77	18.39	9.37	9.96	1.77	2.40	4.65	2.60	3.35	51.92
8-754-4524	1-3/4 x 24	12.7	65.98	43.35	71.77	47.76	24.37	9.37	9.96	1.77	2.40	4.65	2.60	3.35	59.62
8-754-5024	2 x 24	16.8	69.92	48.66	77.95	53.94	24.49	11.81	13.03	2.01	2.68	5.83	2.64	3.74	89.76
8-754-6424	2-1/2 x 24	27.2	73.46	52.09	82.68	58.66	24.61	13.27	13.78	2.52	3.11	6.50	3.07	4.45	157.74
8-754-7024	2-3/4 x 24	34	75.47	54.06	85.67	61.65	24.65	14.92	15.08	2.76	3.27	7.01	3.70	4.17	186.12

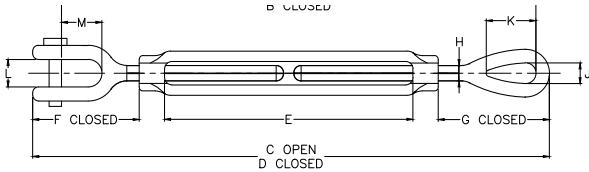

In accordance with Federal Specification FF-T-791b, TYPE1, Form 1, CLASS 8, and ASTM F-1145

Turnbuckle

- Forged steel with hot dipped galvanized finish.
- YOKE turnbuckles are manufactured in accordance with all requirements of ASME B30.26 and designed to fulfill other safety requirements that are not addressed by ASME B30.26.
- YOKE turnbuckles are fitted with locknuts as standard.
- All YOKE jaw end turnbuckles are fitted with bolt and nut for additional safety as standard.
- Maximum Proof Load is 2.5 times WLL.
- Ultimate load is 5 times the WLL.
- Fatigue Rated to 20,000 cycles at 1.5 times the WLL.
- Turnbuckles are recommended for straight or in-line pull only.
- End fittings are Quenched and Tempered at 400°C; bodies are heat treated by normalizing.
- Turnbuckle eyes are enlarged to ease the operation and to minimize stress in the eye.
- Turnbuckle jaws are supplied with bolt and nut for the best security of fittings.

Jaw and Eye Turnbuckle by Metric

Item No.	Thread Dia. & Take up mm	Working Load Limit tonnes*	Dimension(mm)											N.W kg	
			A Open	B Closed	C Open	D Closed	E	F Closed	G Closed	H	J	K	L		M
8-754-0604	6.35 x 102	0.23	294	192	312	210	103	42	45	6	9	21	11	16	0.15
8-754-0804	7.94 x 114	0.36	343	228	363	249	116	51	56	8	11	24	13	22	0.24
8-754-1006	9.53 x 152	0.54	429	277	454	301	155	54	63	10	14	29	14	22	0.36
8-754-1306	12.7 x 152	1	490	338	520	368	153	82	90	13	18	36	16	27	0.8
8-754-1309	12.7 x 229	1	650	421	680	451	238	81	90	13	18	36	16	27	1.02
8-754-1312	12.7 x 305	1	802	497	832	528	314	81	90	13	18	36	16	27	1.21
8-754-1606	15.9 x 152	1.59	527	374	566	413	153	99	110	16	22	46	20	34	1.35
8-754-1609	15.9 x 229	1.59	688	459	727	498	239	99	110	16	22	46	20	34	1.69
8-754-1612	15.9 x 305	1.59	840	535	879	574	315	99	110	16	22	46	20	34	1.97
8-754-1618	15.9 x 457	1.59	1082	687	1118	726	468	99	110	16	22	46	20	34	2.55
8-754-1906	19.1 x 152	2.36	563	411	612	459	156	120	130	19	25	53	25	39	2.05
8-754-1909	19.1 x 229	2.36	726	497	774	546	244	119	129	19	25	53	25	39	2.52
8-754-1912	19.1 x 305	2.36	878	573	927	622	320	119	129	19	25	53	25	39	2.91
8-754-1918	19.1 x 457	2.36	1183	726	1232	774	471	120	130	19	25	53	25	39	3.69
8-754-2212	22.2 x 305	3.27	855	601	963	658	309	140	147	22	32	61	30	45	4.13
8-754-2218	22.2 x 457	3.27	1159	766	1280	822	473	140	147	22	32	61	30	45	5.28
8-754-2606	25.4 x 152	4.54	636	483	701	548	157	155	165	25	36	76	34	52	4.55
8-754-2612	25.4 x 305	4.54	898	636	1006	701	309	155	165	25	36	76	34	52	6.06
8-754-2618	25.4 x 457	4.54	1202	788	1310	853	462	155	165	25	36	76	34	52	7.58
8-754-2624	25.4 x 610	4.54	1509	956	1630	1021	631	154	164	25	36	76	34	52	9.33
8-754-3212	31.8 x 305	6.9	956	730	1117	812	306	205	216	32	46	91	47	72	9.48
8-754-3218	31.8 x 457	6.9	1264	883	1422	965	459	205	216	32	46	91	47	72	11.3
8-754-3224	31.8 x 610	6.9	1565	1050	1741	1131	625	205	216	32	46	91	47	72	13.1
8-754-3812	38.1 x 305	9.71	992	775	1174	869	313	227	240	38	54	104	52	71	13.9
8-754-3818	38.1 x 457	9.71	1296	927	1479	1021	465	227	240	38	54	104	52	71	16.3
8-754-3824	38.1 x 610	9.71	1601	1095	1799	1189	633	227	240	38	54	104	52	71	18.8
8-754-4518	44.5 x 457	12.7	1372	949	1518	1061	467	238	253	45	61	118	66	85	23.6
8-754-4524	44.5 x 610	12.7	1676	1101	1823	1213	619	238	253	45	61	118	66	85	27.1
8-754-5024	51.0 x 610	16.8	1776	1236	1980	1370	622	300	331	51	68	148	67	95	40.8
8-754-6424	63.5 x 610	27.2	1866	1323	2100	1490	625	337	350	64	79	165	78	113	71.7
8-754-7024	70.0 x 610	34	1917	1373	2176	1566	626	379	383	70	83	178	94	106	84.6

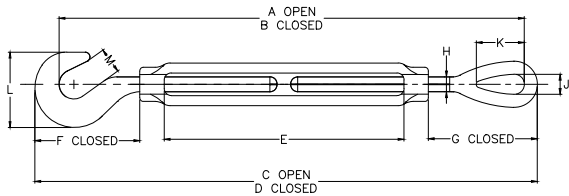

In accordance with Federal Specification FF-T-791b, TYPE1, Form 1, CLASS 6, and ASTM F-1145

Turnbuckles

- Forged steel with hot dipped galvanized finish.
- YOKE turnbuckles are manufactured in accordance with all requirements of ASME B30.26 and designed to fulfill other safety requirements that are not addressed by ASME B30.26.
- YOKE turnbuckles are fitted with locknuts as standard.
- Maximum Proof Load is 2.5 times WLL.
- Ultimate load is 5 times the WLL.
- Fatigue Rated to 20,000 cycles at 1.5 times the WLL.
- Turnbuckles are recommended for straight or in-line pull only.
- End fittings are Quenched and Tempered at 400°C; bodies are heat treated by normalizing.
- The cross sectional area of hooks is designed to be larger for better strength and fatigue properties.
- Turnbuckle eyes are enlarged to ease the operation and to minimize stress in the eye.

Hook and Eye Turnbuckle by Imperial

Item No.	Thread Dia. & Take up	Working Load Limit	Dimension(Inch)											N.W lbs	
			A Open	B Closed	C Open	D Closed	E	F Closed	G Closed	H	J	K	L		M
8-755-0604	1/4 x 4	0.18	11.65	7.68	12.28	8.31	4.06	1.65	1.77	0.24	0.35	0.83	1.26	0.43	0.31
8-755-0804	5/16 x 4-1/2	0.32	13.50	9.02	14.29	9.76	4.57	2.01	2.20	0.31	0.43	0.94	1.50	0.51	0.51
8-755-1006	3/8 x 6	0.45	17.09	11.10	18.03	12.05	6.10	2.28	2.48	0.39	0.55	1.14	1.77	0.55	0.79
8-755-1306	1/2 x 6	0.68	19.57	13.58	20.79	14.80	6.02	3.54	3.54	0.51	0.71	1.42	2.28	0.67	1.80
8-755-1309	1/2 x 9	0.68	25.71	16.73	26.93	17.95	9.37	3.54	3.54	0.51	0.71	1.42	2.28	0.67	2.24
8-755-1312	1/2 x 12	0.68	31.85	19.84	33.07	21.06	12.36	3.50	3.54	0.51	0.71	1.42	2.28	0.67	2.68
8-755-1606	5/8 x 6	1.02	21.10	15.12	22.60	16.61	6.02	4.25	4.33	0.63	0.87	1.81	2.80	0.91	2.97
8-755-1609	5/8 x 9	1.02	27.40	18.31	28.78	19.80	9.41	4.21	4.33	0.63	0.87	1.81	2.80	0.91	3.61
8-755-1612	5/8 x 12	1.02	33.46	21.46	34.96	22.95	12.40	4.25	4.33	0.63	0.87	1.81	2.80	0.91	4.33
8-755-1618	5/8 x 18	1.02	45.83	27.95	47.32	29.29	18.43	4.21	4.33	0.63	0.87	1.81	2.80	0.91	6.05
8-755-1906	3/4 x 6	1.36	22.60	16.61	24.45	18.46	6.10	5.08	5.12	0.75	0.98	2.09	3.35	0.98	4.20
8-755-1909	3/4 x 9	1.36	28.82	19.84	30.71	21.65	9.61	5.04	5.08	0.75	0.98	2.09	3.35	0.98	5.39
8-755-1912	3/4 x 12	1.36	35.00	22.99	36.85	24.84	12.60	5.04	5.08	0.75	0.98	2.09	3.35	0.98	6.51
8-755-1918	3/4 x 18	1.36	47.01	29.02	48.86	30.87	18.54	5.08	5.12	0.75	0.98	2.09	3.35	0.98	8.23
8-755-2212	7/8 x 12	1.81	36.10	24.09	38.23	26.22	12.17	5.83	5.79	0.87	1.26	2.40	3.78	1.14	9.33
8-755-2218	7/8 x 18	1.81	47.64	29.72	50.59	32.48	18.31	5.83	5.75	0.87	1.26	2.40	3.78	1.14	11.33
8-755-2606	1 x 6	2.27	24.80	19.13	27.56	27.95	6.02	6.57	6.50	0.98	1.42	2.99	4.25	1.26	10.34
8-755-2612	1 x 12	2.27	37.64	25.67	40.08	28.07	12.17	6.50	6.50	0.98	1.42	2.99	4.25	1.26	13.84
8-755-2618	1 x 18	2.27	50.16	32.68	52.56	34.65	18.23	6.57	6.50	0.98	1.42	2.99	4.25	1.26	20.90
8-755-2624	1 x 24	2.27	63.78	40.16	64.96	40.94	24.84	6.50	6.50	0.98	1.42	2.99	4.25	1.26	25.96

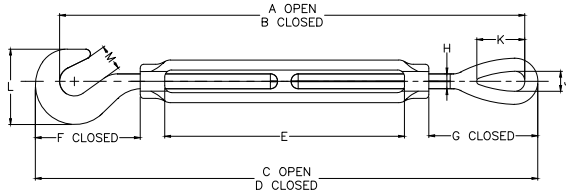

In accordance with Federal Specification FF-T-791b, TYPE1, Form 1, CLASS 6, and ASTM F-1145

Turnbuckles

- Forged steel with hot dipped galvanized finish.
- YOKE turnbuckles are manufactured in accordance with all requirements of ASME B30.26 and designed to fulfill other safety requirements that are not addressed by ASME B30.26.
- YOKE turnbuckles are fitted with locknuts as standard.
- Maximum Proof Load is 2.5 times WLL.
- Ultimate load is 5 times the WLL.
- Fatigue Rated to 20,000 cycles at 1.5 times the WLL.
- Turnbuckles are recommended for straight or in-line pull only.
- End fittings are Quenched and Tempered at 400°C; bodies are heat treated by normalizing.
- The cross sectional area of hooks is designed to be larger for better strength and fatigue properties.
- Turnbuckle eyes are enlarged to ease the operation and to minimize stress in the eye.

Hook and Eye Turnbuckle by Metric

Item No.	Thread Dia. & Take up mm	Working Load Limit tonnes*	Dimension(mm)											N.W kg	
			A Open	B Closed	C Open	D Closed	E	F Closed	G Closed	H	J	K	L		M
8-755-0604	6.35 x 102	0.18	296	195	312	211	103	42	45	6	9	21	32	11	0.14
8-755-0804	7.94 x 114	0.32	343	229	363	248	116	51	56	8	11	24	38	13	0.23
8-755-1006	9.53 x 152	0.45	434	282	458	306	155	58	63	10	14	29	45	14	0.36
8-755-1306	12.7 x 152	0.68	497	345	528	376	153	90	90	13	18	36	58	17	0.82
8-755-1309	12.7 x 229	0.68	653	425	684	456	238	90	90	13	18	36	58	17	1.02
8-755-1312	12.7 x 305	0.68	809	504	840	535	314	89	90	13	18	36	58	17	1.22
8-755-1606	15.9 x 152	1.02	536	384	574	422	153	108	110	16	22	46	71	23	1.35
8-755-1609	15.9 x 229	1.02	696	465	731	503	239	107	110	16	22	46	71	23	1.64
8-755-1612	15.9 x 305	1.02	850	545	888	583	315	108	110	16	22	46	71	23	1.97
8-755-1618	15.9 x 457	1.02	1164	710	1202	744	468	107	110	16	22	46	71	23	2.75
8-755-1906	19.1 x 152	1.36	574	422	621	469	155	129	130	19	25	53	85	25	1.91
8-755-1909	19.1 x 229	1.36	732	504	780	550	244	128	129	19	25	53	85	25	2.45
8-755-1912	19.1 x 305	1.36	889	584	936	631	320	128	129	19	25	53	85	25	2.96
8-755-1918	19.1 x 457	1.36	1194	737	1241	784	471	129	130	19	25	53	85	25	3.74
8-755-2212	22.2 x 305	1.81	917	612	971	666	309	148	147	22	32	61	96	29	4.24
8-755-2218	22.2 x 457	1.81	1210	755	1285	825	465	148	146	22	32	61	96	29	5.15
8-755-2606	25.4 x 152	2.27	630	486	700	710	153	167	165	25	36	76	108	32	4.7
8-755-2612	25.4 x 305	2.27	956	652	1018	713	309	165	165	25	36	76	108	32	6.29
8-755-2618	25.4 x 457	2.27	1274	830	1335	880	463	167	165	25	36	76	108	32	9.5
8-755-2624	25.4 x 610	2.27	1620	1020	1650	1040	631	165	165	25	36	76	108	32	11.8



Wire Rope Clip

- Galvanized finish.
- Forged base for full range of sizes.
- According to the breaking load of the wire rope, YOKE wire rope clips have an efficiency rating of 80% for 1/8" - 7/8" sizes, and 90% for sizes 1" up to 3".
- Manufactured with or exceeds all requirements of ASME B30.26 and EN13411 -2003.

Yoke Wire Rope Clip in accordance with FF-C-450 TYPE 1 CLASS 1 and EN13411-2003.

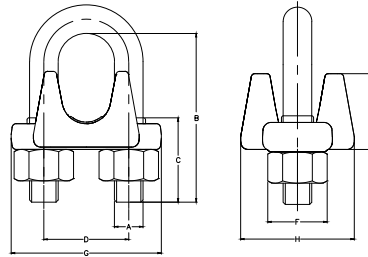

Wire Rope Clip by Imperial

Item No.	Size		Dimension(inch)								N.W lbs
	mm	inch	A	B	C	D	E	F	G	H	
8-762-03	3-4	1/8	0.20	0.98	0.47	0.47	0.39	0.35	0.47	1.02	0.06
8-762-05	5	3/16	0.20	1.18	0.55	0.59	0.51	0.51	0.59	1.22	0.09
8-762-06	6-7	1/4	0.28	1.30	0.59	0.75	0.67	0.55	0.75	1.46	0.19
8-762-08	8	5/16	0.31	1.38	0.75	0.87	0.75	0.67	0.91	1.69	0.31
8-762-10	9-10	3/8	0.35	1.50	0.75	0.98	0.94	0.75	1.18	2.01	0.51
8-762-11	11	7/16	0.43	1.89	0.98	1.18	1.14	0.87	1.46	2.32	0.81
8-762-13	12-13	1/2	0.43	1.89	0.98	1.18	1.14	0.87	1.46	2.28	0.81
8-762-14	14-15	9/16	0.51	2.40	1.26	1.30	1.22	0.94	1.61	2.52	1.06
8-762-16	16	5/8	0.51	2.40	1.26	1.30	1.38	0.94	1.61	2.52	1.06
8-762-19	18-20	3/4	0.55	2.76	1.46	1.50	1.38	1.06	2.24	2.83	1.50
8-762-22	22	7/8	0.67	3.11	1.61	1.77	1.50	1.26	2.09	3.19	2.20
8-762-26	24-26	1	0.67	3.50	1.81	1.89	1.69	1.26	2.36	3.50	2.66
8-762-28	28-30	1-1/8	0.67	3.90	2.01	2.01	1.97	1.26	2.52	3.62	2.99
8-762-32	32-34	1-1/4	0.79	4.25	2.13	2.32	2.17	1.46	2.91	4.13	4.58
8-762-36	36	1-3/8	0.79	4.25	2.13	2.32	2.28	1.46	3.07	4.17	4.91
8-762-38	38	1-1/2	0.79	4.92	2.40	2.64	2.40	1.46	3.35	4.45	5.46
8-762-42	41-42	1-5/8	0.87	5.31	2.64	2.76	2.68	1.61	3.54	4.80	7.22
8-762-45	44-46	1-3/4	0.94	5.75	2.76	3.07	2.99	1.81	3.82	5.28	9.42
8-762-50	48-52	2	1.26	6.46	2.99	3.39	3.07	2.01	4.33	5.91	13.75
8-762-57	56-58	2-1/4	1.26	7.05	3.66	3.90	3.23	2.01	4.49	6.54	15.62
8-762-64	62-65	2-1/2	1.26	7.60	3.74	4.13	3.66	2.01	5.04	6.69	17.34
8-762-70	68-72	2-3/4	1.26	8.19	3.82	4.37	4.13	2.01	5.39	7.01	21.03
8-762-75	75-78	3	1.50	9.13	4.09	4.72	4.53	2.40	5.91	7.64	32.56

Wire Rope Clip



- Galvanized finish.
- Forged base for full range of sizes.
- According to the breaking load of the wire rope, YOKE wire rope clips have an efficiency rating of 80% for 1/8" - 7/8" sizes, and 90% for sizes 1" up to 3".
- Manufactured with or exceeds all requirements of ASME B30.26 and EN13411 -2003.

YOKE Wire Rope Clip in accordance with FF-C-450 TYPE 1 CLASS 1 and EN13411-2003.

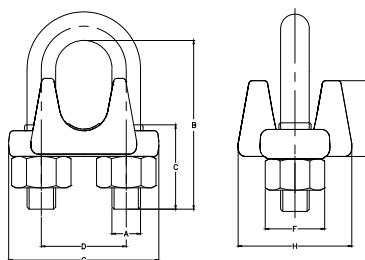

Wire Rope Clip by Metric

Item No.	Size		Dimension(mm)								N.W kg
	mm	inch	A	B	C	D	E	F	G	H	
8-762-03	3-4	1/8	5	25	12	12	10	9	12	26	0.03
8-762-05	5	3/16	5	30	14	15	13	13	15	31	0.04
8-762-06	6-7	1/4	7	33	15	19	17	14	19	37	0.09
8-762-08	8	5/16	8	35	19	22	19	17	23	43	0.14
8-762-10	9-10	3/8	9	38	19	25	24	19	30	51	0.23
8-762-11	11	7/16	11	48	25	30	29	22	37	59	0.37
8-762-13	12-13	1/2	11	48	25	30	29	22	37	58	0.37
8-762-14	14-15	9/16	13	61	32	33	31	24	41	64	0.48
8-762-16	16	5/8	13	61	32	33	35	24	41	64	0.48
8-762-19	18-20	3/4	14	70	37	38	35	27	57	72	0.68
8-762-22	22	7/8	17	79	41	45	38	32	53	81	1.0
8-762-26	24-26	1	17	89	46	48	43	32	60	89	1.21
8-762-28	28-30	1-1/8	17	99	51	51	50	32	64	92	1.36
8-762-32	32-34	1-1/4	20	108	54	59	55	37	74	105	2.08
8-762-36	36	1-3/8	20	108	54	59	58	37	78	106	2.23
8-762-38	38	1-1/2	20	125	61	67	61	37	85	113	2.48
8-762-42	41-42	1-5/8	22	135	67	70	68	41	90	122	3.28
8-762-45	44-46	1-3/4	24	146	70	78	76	46	97	134	4.28
8-762-50	48-52	2	32	164	76	86	78	51	110	150	6.25
8-762-57	56-58	2-1/4	32	179	93	99	82	51	114	166	7.1
8-762-64	62-65	2-1/2	32	193	95	105	93	51	128	170	7.88
8-762-70	68-72	2-3/4	32	208	97	111	105	51	137	178	9.56
8-762-75	75-78	3	38	232	104	120	115	61	150	194	14.8



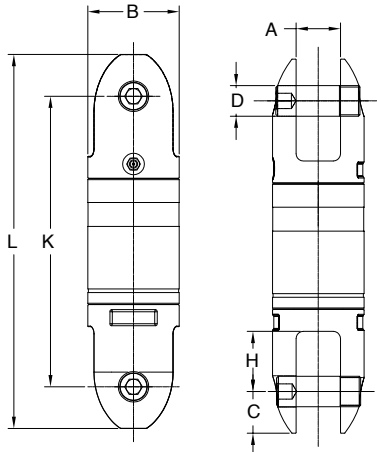

- YOKE Swivels are manufactured using the highest grade of material available.
- YOKE Swivels are designed with a safety factor of 5:1.
- YOKE Swivels are available in sizes from 3/4 Tons to 35 Tons.
- YOKE Swivels are available for wire lines 1/4" to 1-1/2".
- YOKE Swivels are zinc plated for corrosion resistance and longer life.
- YOKE Swivels are manufactured with grease fittings for superior performance.
- YOKE Swivels are designed for low starting torque and high rotation speed.
- All Swivels parts are 100% magnaflux crack detected.
- 20,000 cycle fatigue rate to 1.5 times working load limit.
- All parts with batch number for quality certified and traceability.

Angular Contact Bearing Swivels - Bullet Style

Item No.	Wire Line Size	Working Load Limit Tons*	Dimensions (inch)							N.W. lbs
	inch		B	K	L	C	A	D	H	
8-301-0075	1/4	0.75	1.30	4.00	5.00	0.50	0.60	0.40	0.90	1.1
8-301-015	3/8	1.5	1.60	4.40	5.70	0.60	0.70	0.50	1.00	1.7
8-301-03	1/2	3	2.00	6.30	8.00	0.90	0.90	0.60	1.20	4.4
8-301-05	5/8	5	2.50	8.00	10.30	1.20	1.30	0.90	1.50	8.7
8-301-085	3/4	8.5	3.00	9.50	12.30	1.40	1.50	1.00	2.00	14.8
8-301-10	7/8	10	4.00	12.50	16.00	1.80	1.70	1.50	2.10	40.0
8-301-15	1	15	4.30	12.50	16.00	1.80	2.00	1.50	2.20	46.2
8-301-25	1 1/4	25	5.20	14.70	19.50	2.40	2.50	2.00	2.70	80.5
8-301-35	1 1/2	35	5.20	14.70	19.50	2.40	2.50	2.00	2.70	94.4

★ Minimum Ultimate Load is 5 times the Working Load Limit.
 Maximum Proof Load is 2 times the Working Load Limit.

Item No.	Wire Line Size	Working Load Limit Tons*	Dimensions (mm)							N.W. kg
	mm		B	K	L	C	A	D	H	
8-301-0075	6	0.75	32	103	126	12	15	10	22	0.5
8-301-015	10	1.5	40	112	144	16	18	11	26	0.8
8-301-03	13	3	51	159	203	23	23	16	31	2.0
8-301-05	16	5	64	200	262	31	32	22	37	4.0
8-301-085	19	8.5	76	242	312	35	37	25	50	6.7
8-301-10	22	10	102	317	408	46	42	38	53	18.2
8-301-15	25	15	108	317	408	46	48	38	56	21.0
8-301-25	32	25	132	374	495	61	62	51	69	36.5
8-301-35	38	35	132	374	495	61	62	51	69	42.9

★ Minimum Ultimate Load is 5 times the Working Load Limit.
 Maximum Proof Load is 2 times the Working Load Limit.

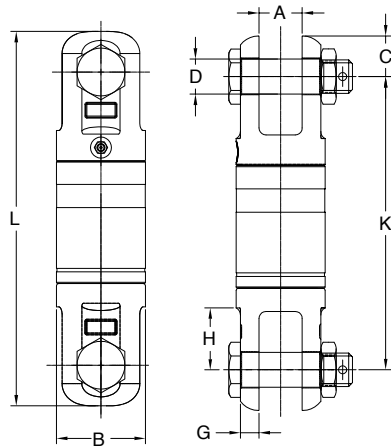

- YOKE Swivels are manufactured using the highest grade of material available.
- YOKE Swivels are designed with a safety factor of 5:1.
- YOKE Swivels are available in sizes from 3/4 Tons to 35 Tons.
- YOKE Swivels are available for wire lines 1/4" to 1-1/2".
- YOKE Swivels are zinc plated for corrosion resistance and longer life.
- YOKE Swivels are manufactured with grease fittings for superior performance.
- YOKE Swivels are designed for low starting torque and high rotation speed.
- All Swivels parts are 100% magnaflux crack detected.
- 20,000 cycle fatigue rate to 1.5 times working load limit.
- All parts with batch number for quality certified and traceability.

Angular Contact Bearing Swivels - Jaw + Jaw

Item No.	Wire Line Size	Working Load Limit	Dimensions (inch)								N.W.
	inch		Tons*	A	B	C	D	G	H	K	
8-303-0075	1/4	0.75	0.60	1.30	0.50	0.40	0.20	0.90	4.10	5.00	1.1
8-303-015	3/8	1.5	0.70	1.60	0.80	0.50	0.30	1.00	4.40	6.00	2.0
8-303-03	1/2	3	0.90	2.00	1.00	0.80	0.40	1.30	6.20	8.20	5.1
8-303-05	5/8	5	1.30	2.50	1.20	0.90	0.60	1.50	8.00	10.30	9.7
8-303-085	3/4	8.5	1.60	3.00	1.30	1.20	0.60	2.10	10.00	12.60	16.8
8-303-10	7/8	10	1.70	4.00	1.90	1.50	1.00	2.10	12.40	16.20	43.0
8-303-15	1	15	1.90	4.30	2.00	1.50	1.00	2.20	12.40	16.50	47.8
8-303-25	1 1/4	25	2.40	5.20	2.60	2.00	1.20	2.80	14.70	20.00	87.0
8-303-35	1 1/2	35	2.40	5.20	2.60	2.00	1.20	2.80	14.70	20.00	102.0

★ Minimum Ultimate Load is 5 times the Working Load Limit.
 Maximum Proof Load is 2 times the Working Load Limit.

Item No.	Wire Line Size	Working Load Limit	Dimensions (mm)								N.W.
	mm		Tons*	A	B	C	D	G	H	K	
8-303-0075	6	0.75	15	32	13	10	6	22	103	128	0.5
8-303-015	10	1.5	18	40	20	13	8	26	112	152	0.9
8-303-03	13	3	23	51	25	19	10	32	158	208	2.3
8-303-05	16	5	32	64	31	22	14	37	200	261	4.4
8-303-085	19	8.5	40	76	34	30	14	54	252	320	7.6
8-303-10	22	10	42	102	48	38	25	54	316	412	19.5
8-303-15	25	15	48	108	52	38	25	57	316	420	21.7
8-303-25	32	25	62	132	65	51	30	70	374	503	39.5
8-303-35	38	35	62	132	65	51	30	70	374	503	46.2

★ Minimum Ultimate Load is 5 times the Working Load Limit.
 Maximum Proof Load is 2 times the Working Load Limit.

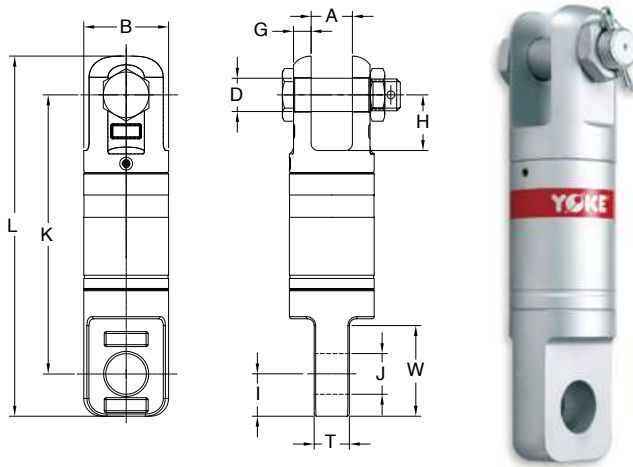

- YOKE Swivels are manufactured using the highest grade of material available.
- YOKE Swivels are designed with a safety factor of 5:1.
- YOKE Swivels are available in sizes from 3/4 Tons to 35 Tons.
- YOKE Swivels are available for wire lines 1/4" to 1-1/2".
- YOKE Swivels are zinc plated for corrosion resistance and longer life.
- YOKE Swivels are manufactured with grease fittings for superior performance.
- YOKE Swivels are designed for low starting torque and high rotation speed.
- All Swivels parts are 100% magnaflux crack detected.
- 20,000 cycle fatigue rate to 1.5 times working load limit.
- All parts with batch number for quality certified and traceability.

Angular Contact Bearing Swivels - Jaw + Eye

Item No.	Wire Line Size	Working Load Limit	Dimensions (inch)											N.W. lbs
	inch		Tons*	A	B	D	G	H	I	J	K	L	T	
8-304-0075	1/4	0.75	0.60	1.30	0.40	0.20	0.90	0.70	0.80	4.10	5.30	0.50	1.50	1.1
8-304-015	3/8	1.5	0.70	1.60	0.50	0.30	1.00	0.90	0.90	4.50	6.10	0.60	1.70	2.0
8-304-03	1/2	3	0.90	2.00	0.80	0.40	1.30	1.10	1.10	6.20	8.30	0.80	2.00	4.8
8-304-05	5/8	5	1.30	2.50	0.90	0.60	1.50	1.30	1.30	8.10	10.60	1.00	2.30	9.7
8-304-085	3/4	8.5	1.60	3.00	1.20	0.60	2.10	1.50	1.50	9.80	12.70	1.30	3.20	16.3
8-304-10	7/8	10	1.70	4.00	1.50	1.00	2.10	2.00	1.70	12.30	16.20	1.70	3.50	39.0
8-304-15	1	15	1.90	4.30	1.50	1.00	2.20	2.50	2.10	12.50	17.10	1.90	4.30	47.6
8-304-25	1 1/4	25	2.40	5.20	2.00	1.20	2.80	2.80	2.60	15.40	20.60	2.40	5.10	87.3
8-304-35	1 1/2	35	2.40	5.20	2.00	1.20	2.80	2.80	2.60	15.40	20.60	2.40	5.10	102.3

★ Minimum Ultimate Load is 5 times the Working Load Limit.

Maximun Proof Load is 2 times the Working Load Limit.

Item No.	Wire Line Size	Working Load Limit	Dimensions (mm)											N.W. kg
	mm		Tons*	A	B	D	G	H	I	J	K	L	T	
8-304-0075	6	0.75	15	32	10	6	22	18	19	103	134	12	37	0.5
8-304-015	10	1.5	18	40	13	7	26	22	23	115	156	15	43	0.9
8-304-03	13	3	23	51	19	10	32	28	27	158	211	20	51	2.2
8-304-05	16	5	32	64	22	14	37	33	33	205	269	26	59	4.4
8-304-085	19	8.5	40	76	30	14	54	38	37	250	322	32	82	7.4
8-304-10	22	10	42	102	38	25	54	52	44	312	412	42	90	17.5
8-304-15	25	15	48	108	38	25	57	64	54	317	434	49	110	21.6
8-304-25	32	25	62	132	51	30	70	70	66	390	524	60	130	39.7
8-304-35	32	35	62	132	51	30	70	70	66	390	524	60	130	46.4

★ Minimum Ultimate Load is 5 times the Working Load Limit.

Maximun Proof Load is 2 times the Working Load Limit.

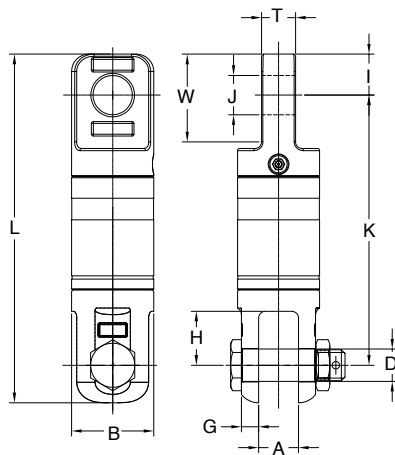

- YOKE Swivels are manufactured using the highest grade of material available.
- YOKE Swivels are designed with a safety factor of 5:1.
- YOKE Swivels are available in sizes from 3/4 Tons to 35 Tons.
- YOKE Swivels are available for wire lines 1/4" to 1-1/2".
- YOKE Swivels are zinc plated for corrosion resistance and longer life.
- YOKE Swivels are manufactured with grease fittings for superior performance.
- YOKE Swivels are designed for low starting torque and high rotation speed.
- All Swivels parts are 100% magnaflux crack detected.
- 20,000 cycle fatigue rate to 1.5 times working load limit.
- All parts with batch number for quality certified and traceability.

Angular Contact Bearing Swivels - Eye + Jaw

Item No.	Wire Line Size	Working Load Limit Tons*	Dimensions (inch)										N.W.	
	inch		A	B	D	G	H	I	J	K	L	T	W	lbs
8-305-0075	1/4	0.75	0.60	1.30	0.40	0.20	0.90	0.70	0.80	4.06	5.28	0.50	1.50	1.1
8-305-015	3/8	1.5	0.70	1.60	0.50	0.30	1.00	0.90	0.90	4.53	6.14	0.60	1.70	2.0
8-305-03	1/2	3	0.90	2.00	0.80	0.40	1.30	1.10	1.10	6.22	8.31	0.80	2.00	4.8
8-305-05	5/8	5	1.30	2.50	0.90	0.60	1.50	1.30	1.30	8.07	10.60	1.00	2.30	9.7
8-305-085	3/4	8.5	1.60	3.00	1.20	0.60	2.10	1.50	1.50	9.84	12.68	1.30	3.20	16.4
8-305-10	7/8	10	1.70	4.00	1.50	1.00	2.10	2.00	1.70	12.28	16.22	1.70	3.50	39.6
8-305-15	1	15	1.90	4.30	1.50	1.00	2.20	2.50	2.10	12.50	17.10	1.90	4.30	46.7
8-305-25	1 1/4	25	2.40	5.20	2.00	1.20	2.80	2.80	2.60	15.35	20.63	2.40	5.10	88.0
8-305-35	1 1/2	35	2.40	5.20	2.00	1.20	2.80	2.80	2.60	15.35	20.63	2.40	5.10	103.0

★ Minimum Ultimate Load is 5 times the Working Load Limit.

Maximun Proof Load is 2 times the Working Load Limit.

Item No.	Wire Line Size	Working Load Limit Tons*	Dimensions (mm)										N.W.	
	mm		A	B	D	G	H	I	J	K	L	T	W	kg
8-305-0075	6	0.75	15	32	10	6	22	18	19	103	134	12	37	0.5
8-305-015	10	1.5	18	40	13	7	26	22	23	115	156	15	43	0.9
8-305-03	13	3	23	51	19	10	32	28	27	158	211	20	51	2.2
8-305-05	16	5	32	64	22	14	37	33	33	204	268	26	59	4.4
8-305-085	19	8.5	40	76	30	14	54	38	37	250	322	32	82	7.4
8-305-10	22	10	42	102	38	25	54	52	44	313	413	42	90	18.0
8-305-15	25	15	48	108	38	25	57	64	54	314	430	49	110	21.2
8-305-25	32	25	62	132	51	30	70	70	66	391	526	60	130	40.0
8-305-35	38	35	62	132	51	30	70	70	66	391	526	60	130	46.7

★ Minimum Ultimate Load is 5 times the Working Load Limit.

Maximun Proof Load is 2 times the Working Load Limit.

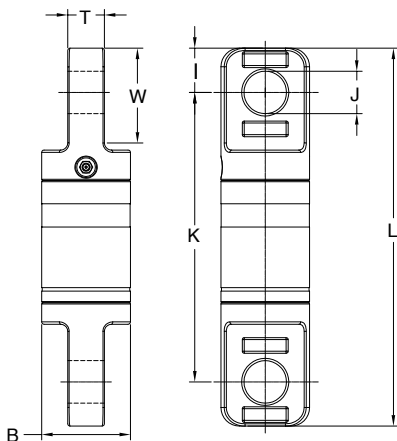

- YOKE Swivels are manufactured using the highest grade of material available.
- YOKE Swivels are designed with a safety factor of 5:1.
- YOKE Swivels are available in sizes from 3/4 Tons to 35 Tons.
- YOKE Swivels are available for wire lines 1/4" to 1-1/2".
- YOKE Swivels are zinc plated for corrosion resistance and longer life.
- YOKE Swivels are manufactured with grease fittings for superior performance.
- YOKE Swivels are designed for low starting torque and high rotation speed.
- All Swivels parts are 100% magnaflux crack detected.
- 20,000 cycle fatigue rate to 1.5 times working load limit.
- All parts with batch number for quality certified and traceability.

Angular Contact Bearing Swivels - Eye + Eye

Item No.	Wire Line Size	Working Load Limit Tons*	Dimensions (inch)							N.W. lbs
	inch		B	I	J	K	L	T	W	
8-306-0075	1/4	0.75	1.30	0.70	0.70	4.10	5.50	0.50	1.50	1.1
8-306-015	3/8	1.50	1.60	0.90	0.90	4.60	6.30	0.60	1.70	2.0
8-306-03	1/2	3	2.00	1.10	1.10	6.20	8.40	0.80	2.00	4.6
8-306-05	5/8	5	2.50	1.30	1.30	8.30	10.90	1.00	2.30	9.7
8-306-085	3/4	8.50	3.00	1.50	1.50	9.80	12.80	1.30	3.20	16.1
8-306-10	7/8	10	4.00	2.10	2.00	12.20	16.30	1.70	3.50	37.4
8-306-15	1	15	4.30	2.50	2.50	12.40	17.40	1.90	4.30	46.3
8-306-25	1 1/4	25	5.20	2.80	2.80	16.00	21.50	2.40	5.10	86.0
8-306-35	1 1/2	35	5.20	2.80	2.80	16.00	21.50	2.40	5.10	101.0

★ Minimum Ultimate Load is 5 times the Working Load Limit.

Maximum Proof Load is 2 times the Working Load Limit.

Item No.	Wire Line Size	Working Load Limit Tons*	Dimensions (mm)							N.W. kg
	mm		B	I	J	K	L	T	W	
8-306-0075	6	0.75	32	18	19	103	139	12	37	0.5
8-306-015	10	1.50	40	22	23	117	160	15	43	0.9
8-306-03	13	3	51	28	27	158	214	20	51	2.1
8-306-05	16	5	64	33	33	210	276	26	59	4.4
8-306-085	19	8.50	76	38	37	249	325	32	82	7.3
8-306-10	22	10	102	52	44	310	413	42	90	17.0
8-306-15	25	15	108	64	54	316	443	49	110	21.0
8-306-25	32	25	132	70	66	407	547	60	130	39.0
8-306-35	38	35	132	70	66	407	547	60	130	45.8

★ Minimum Ultimate Load is 5 times the Working Load Limit.

Maximum Proof Load is 2 times the Working Load Limit.

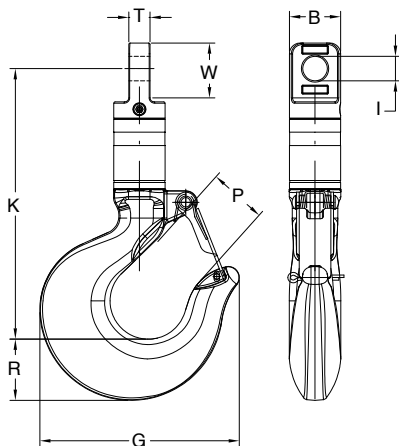

- YOKE Swivels are manufactured using the highest grade of material available.
- YOKE Swivels are designed with a safety factor of 5:1.
- YOKE Swivels are available in sizes from 3/4 Tons to 35 Tons.
- YOKE Swivels are available for wire lines 1/4" to 1-1/4".
- YOKE Swivels are zinc plated for corrosion resistance and longer life.
- YOKE Swivels are manufactured with grease fittings for superior performance.
- YOKE Swivels are designed for low starting torque and high rotation speed.
- All Swivels parts are 100% magnaflux crack detected.
- 20,000 cycle fatigue rate to 1.5 times working load limit.
- All parts with batch number for quality certified and traceability.

Angular Contact Bearing Swivels - Eye + Hook

Item No.	Wire Line Size	Working Load Limit Tons*	Dimensions (inch)								N.W. lbs
	inch		B	G	I	K	P	R	T	W	
8-307-0075	1/4	0.75	1.30	3.15	0.71	6.20	1.00	0.83	0.39	1.57	1.5
8-307-015	3/8	1.5	1.60	4.02	0.87	7.30	1.20	1.14	0.59	1.92	3.1
8-307-03	1/2	3	2.00	5.13	1.06	9.60	1.40	1.42	0.87	2.09	7.0
8-307-05	5/8	5	2.50	6.54	1.29	12.44	1.70	1.85	1.02	2.76	14.3
8-307-085	3/4	8.5	3.00	8.69	1.46	15.00	2.40	2.60	1.26	3.43	29.3
8-307-10	7/8	10	4.00	10.91	3.19	18.38	3.20	3.00	1.65	4.17	57.0
8-307-15	1	15	4.30	10.91	3.19	19.10	3.20	3.00	1.93	4.88	63.6
8-307-25	1 1/4	25	5.20	13.89	3.27	22.95	3.30	3.62	2.32	5.71	119.9

★ Minimum Ultimate Load is 5 times the Working Load Limit.
 Maximun Proof Load is 2 times the Working Load Limit.

Item No.	Wire Line Size	Working Load Limit Tons*	Dimensions (mm)								N.W. kg
	mm		B	G	I	K	P	R	T	W	
8-307-0075	6	0.75	32	80	18	157	25	21	10	40	0.7
8-307-015	10	1.5	40	102	22	185	30	29	15	48	1.4
8-307-03	13	3	51	130	27	243	36	36	22	53	3.2
8-307-05	16	5	64	166	33	316	43	47	26	70	6.5
8-307-085	19	8.5	76	221	37	381	62	66	32	87	13.3
8-307-10	22	10	102	277	44	467	81	76	42	106	25.9
8-307-15	25	15	108	277	54	485	81	76	49	124	28.9
8-307-25	32	25	132	353	66	583	83	92	59	145	54.5

★ Minimum Ultimate Load is 5 times the Working Load Limit.
 Maximun Proof Load is 2 times the Working Load Limit.

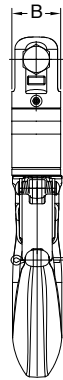
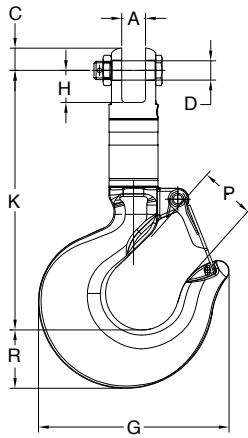

- YOKE Swivels are manufactured using the highest grade of material available.
- YOKE Swivels are designed with a safety factor of 5:1.
- YOKE Swivels are available in sizes from 3/4 Tons to 35 Tons.
- YOKE Swivels are available for wire lines 1/4" to 1-1/4".
- YOKE Swivels are zinc plated for corrosion resistance and longer life.
- YOKE Swivels are manufactured with grease fittings for superior performance.
- YOKE Swivels are designed for low starting torque and high rotation speed.
- All Swivels parts are 100% magnaflux crack detected.
- 20,000 cycle fatigue rate to 1.5 times working load limit.
- All parts with batch number for quality certified and traceability.

Angular Contact Bearing Swivels - Jaw + Hook

Item No.	Wire Line Size	Working Load Limit	Dimensions (inch)									N.W.
	inch		Tons*	A	B	C	D	G	H	K	P	
8-308-0075	1/4	0.75	0.40	1.30	0.50	0.40	3.15	0.90	5.48	1.00	0.83	1.5
8-308-015	3/8	1.5	0.50	1.60	0.80	0.50	4.02	1.00	6.33	1.20	1.14	3.3
8-308-03	1/2	3	0.75	2.00	0.91	0.75	5.13	1.30	8.66	1.40	1.42	7.3
8-308-05	5/8	5	0.87	2.50	1.20	0.87	6.54	1.50	10.99	1.70	1.85	14.1
8-308-085	3/4	8.5	1.18	3.00	1.37	1.18	8.69	1.97	13.58	2.40	2.60	29.5
8-308-10	7/8	10	1.50	4.00	1.89	1.50	10.91	2.10	16.49	3.20	3.00	60.0
8-308-15	1	15	1.50	4.30	2.02	1.50	10.91	2.20	16.57	3.20	3.00	63.7
8-308-25	1 1/4	25	2.00	5.20	2.56	2.00	13.89	2.74	19.53	3.30	3.62	124.5

★ Minimum Ultimate Load is 5 times the Working Load Limit.
 Maximun Proof Load is 2 times the Working Load Limit.

Item No.	Wire Line Size	Working Load Limit	Dimensions (mm)									N.W.
	mm		Tons*	A	B	C	D	G	H	K	P	
8-308-0075	6	0.75	15	32	13	10	80	22	139	25	21	0.7
8-308-015	10	1.5	18	40	20	13	102	26	161	30	29	1.5
8-308-03	13	3	23	51	23	19	130	32	220	36	36	3.3
8-308-05	16	5	32	64	31	22	166	37	279	43	47	6.4
8-308-085	19	8.5	37	76	35	30	221	50	335	62	66	13.4
8-308-10	22	10	42	102	48	38	277	54	419	81	76	27.2
8-308-15	25	15	48	108	52	38	277	56	421	81	76	28.9
8-308-25	32	25	62	132	65	51	353	69	496	83	92	56.6

★ Minimum Ultimate Load is 5 times the Working Load Limit.
 Maximun Proof Load is 2 times the Working Load Limit.



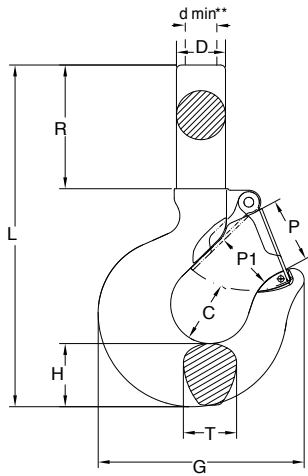

- YOKE alloy shank hoist hook are manufactured from the finest quality alloy steel.
- YOKE shank hoist hook are quenched and tempered.
- 20,000 cycle fatigue rate to 1.5 times working load limit.
- All shank hoist hooks are 100% magnaflux crack detected.
- All parts with batch number for quality certified and traceability.
- YOKE Shank Hoist Hooks are proof tested to 2 times the working load limit..
- YOKE Shank Hoist Hooks are supplied without threads
- YOKE Shank Hoist Hooks are Predrilled to accept a YOKE latch kits.
- YOKE Shank Hoist Hooks are supplied with certification for each hook.

Alloy Shank Hoist Hook

Self Colored

Item No.		Working Load Limit tonnes*	Hook Feature Code	Dimensions (inch)										N.W. lbs
with latch	without latch			C	D	d min**	G	H	L	P	P1	R	T	
8-171.SC-01	8-171.SC/0-01	1	AA	0.97	0.79	0.53	3.07	0.75	5.39	1.02	0.87	2.00	0.63	0.9
8-171.SC-015	8-171.SC/0-015	1.5	BB	0.97	0.66	0.62	3.15	0.87	5.98	0.95	0.75	2.45	0.71	1.3
8-171.SC-02	8-171.SC/0-02	2	CC	1.03	0.72	0.66	3.58	1.00	6.38	1.06	0.79	2.56	0.88	1.8
8-171.SC-03	8-171.SC/0-03	3	DD	1.16	0.88	0.81	4.02	1.18	7.72	1.22	0.98	2.91	0.94	2.6
8-171.SC-05	8-171.SC/0-05	5	EE	1.53	1.26	1.03	5.12	1.46	9.45	1.42	1.22	3.50	1.31	5.1
8-171.SC-07	8-171.SC/0-07	7	FF	1.94	1.41	1.27	6.54	1.82	11.18	1.77	1.54	3.89	1.66	9.2
8-171.SC-11	8-171.SC/0-11	11	GG	2.46	1.81	1.52	7.72	2.28	12.91	2.40	2.24	4.41	1.88	15.4
8-171.SC-15	8-171.SC/0-15	15	HH	2.59	2.00	1.75	8.70	2.60	13.54	2.83	2.44	4.53	2.19	20.9
8-171.SC-22	8-171.SC/0-22	22	JJ	2.81	2.56	2.00	10.91	3.01	16.97	3.39	3.19	5.91	2.69	41.8
8-171.SC-30	8-171.SC/0-30	30	KK	3.44	3.12	2.50	13.90	3.62	23.07	3.50	3.27	10.00	3.00	74.8

★ Minimum Ultimate Load is 5 times the Working Load Limit. Maximun Proof Load is 2 times the Working Load Limit.

**d min.:After machining the shank, proof loading must be carried out.

*S.C.=Self Colored

Item No.		Working Load Limit tonnes*	Hook Feature Code	Dimensions (mm)										N.W. kg
with latch	without latch			C	D	d min**	G	H	L	P	P1	R	T	
8-171.SC-01	8-171.SC/0-01	1	AA	25	20	13	78	19	137	25	26	51	16	0.4
8-171.SC-015	8-171.SC/0-015	1.5	BB	25	23	15	80	22	152	24	27	62	18	0.6
8-171.SC-02	8-171.SC/0-02	2	CC	26	26	16	91	25	162	24	27	65	22	0.8
8-171.SC-03	8-171.SC/0-03	3	DD	29	29	20	102	30	196	28	31	74	24	1.2
8-171.SC-05	8-171.SC/0-05	5	EE	38	32	26	130	37	240	35	37	89	33	2.3
8-171.SC-07	8-171.SC/0-07	7	FF	49	39	32	166	46	284	43	46	99	42	4.2
8-171.SC-11	8-171.SC/0-11	11	GG	62	45	38	196	58	328	61	64	112	48	7.0
8-171.SC-15	8-171.SC/0-15	15	HH	65	51	44	221	66	344	72	75	115	56	9.5
8-171.SC-22	8-171.SC/0-22	22	JJ	71	67	50	277	77	431	92	95	150	68	19.0
8-171.SC-30	8-171.SC/0-30	30	KK	87	70	63	353	92	586	89	93	254	76	34.0

★ Minimum Ultimate Load is 5 times the Working Load Limit. Maximun Proof Load is 2 times the Working Load Limit.

**d min.:After machining the shank, proof loading must be carried out.

*S.C.=Self Colored

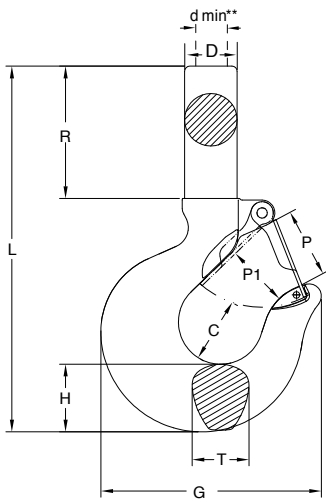

- YOKE carbon shank hoist hook are manufactured from the finest quality carbon steel.
- YOKE shank hoist hook are quenched and tempered.
- 20,000 cycle fatigue rate to 1.5 times working load limit.
- All shank hoist hooks are 100% magnaflux crack detected.
- All parts with batch number for quality certified and traceability.
- YOKE Shank Hoist Hooks are proof tested to 2 times the working load limit.
- YOKE Shank Hoist Hooks are supplied without threads.
- YOKE Shank Hoist Hooks are Pre-drilled to accept a YOKE latch kits.
- YOKE Shank Hoist Hooks are supplied with certification for each hook.

Carbon Shank Hoist Hook

Self Colored

Item No.		Working Load Limit tonnes*	Hook Feature Code	Dimensions (inch)										N.W. lbs
with latch	without latch			C	D	d min**	G	H	L	P	P1	R	T	
8-191.SC-0075	8-191.SC/0-0075	0.75	AA	0.97	0.79	0.53	3.07	0.75	5.39	0.98	1.02	2.00	0.63	0.9
8-191.SC-01	8-191.SC/0-01	1	BB	0.97	0.66	0.62	3.15	0.87	5.98	0.94	1.06	2.45	0.71	1.3
8-191.SC-015	8-191.SC/0-015	1.5	CC	1.03	0.72	0.66	3.58	1.00	6.38	0.94	1.06	2.56	0.88	1.8
8-191.SC-02	8-191.SC/0-02	2	DD	1.16	0.88	0.81	4.02	1.18	7.72	1.16	1.22	2.91	0.94	2.6
8-191.SC-03	8-191.SC/0-03	3	EE	1.53	1.26	1.03	5.12	1.46	9.45	1.38	1.46	3.50	1.31	5.1
8-191.SC-05	8-191.SC/0-05	5	FF	1.94	1.41	1.27	6.54	1.82	11.18	1.69	1.81	3.89	1.66	9.5
8-191.SC-075	8-191.SC/0-075	7.5	GG	2.46	1.81	1.52	7.72	2.28	12.91	2.40	2.51	4.41	1.88	15.4
8-191.SC-10	8-191.SC/0-10	10	HH	2.59	2.00	1.75	8.70	2.60	13.54	2.83	2.95	4.53	2.19	20.9
8-191.SC-15	8-191.SC/0-15	15	JJ	2.81	2.56	2.00	10.91	3.01	16.97	3.63	3.74	5.91	2.69	40.7
8-191.SC-20	8-191.SC/0-20	20	KK	3.44	3.12	2.50	13.90	3.62	23.07	3.50	3.66	10.00	3.00	75.2

★ Minimum Ultimate Load is 5 times the Working Load Limit. Maximum Proof Load is 2 times the Working Load Limit.

**d min.:After machining the shank, proof loading must be carried out.

*S.C.=Self Colored

Item No.		Working Load Limit tonnes*	Hook Feature Code	Dimensions (mm)										N.W. kg
with latch	without latch			C	D	d min**	G	H	L	P	P1	R	T	
8-191.SC-0075	8-191.SC/0-0075	0.75	AA	25	20	13	78	19	137	25	26	51	16	0.4
8-191.SC-01	8-191.SC/0-01	1	BB	25	23	15	80	22	152	24	27	62	18	0.6
8-191.SC-015	8-191.SC/0-015	1.5	CC	26	26	16	91	25	162	24	27	65	22	0.8
8-191.SC-02	8-191.SC/0-02	2	DD	29	29	20	102	30	196	28	31	74	24	1.2
8-191.SC-03	8-191.SC/0-03	3	EE	38	32	26	130	37	240	35	37	89	33	2.3
8-191.SC-05	8-191.SC/0-05	5	FF	49	38	32	166	46	284	43	46	99	42	4.3
8-191.SC-075	8-191.SC/0-075	7.5	GG	62	45	38	196	58	328	61	64	112	48	7.0
8-191.SC-10	8-191.SC/0-10	10	HH	65	51	44	221	66	344	72	75	115	56	9.5
8-191.SC-15	8-191.SC/0-15	15	JJ	71	67	50	277	77	431	92	95	150	68	18.5
8-191.SC-20	8-191.SC/0-20	20	KK	87	70	63	353	92	586	89	93	254	76	34.2

★ Minimum Ultimate Load is 5 times the Working Load Limit. Maximum Proof Load is 2 times the Working Load Limit.

**d min.:After machining the shank, proof loading must be carried out.

*S.C.=Self Colored

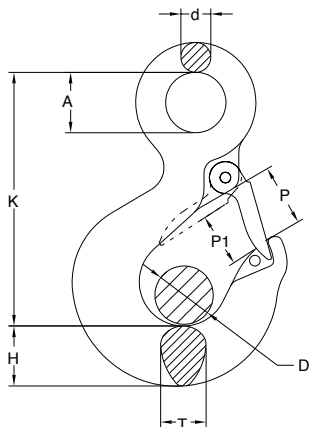

- YOKE alloy eye hoist hook are manufactured from the finest quality alloy steel.
- YOKE eye hoist hook are quenched and tempered.
- 20,000 cycle fatigue rated to 1.5 times of 4:1 WLL, Hook Code AA and KK to 1.5 times of 5:1 WLL.
- All eye hoist hooks are 100% magnaflux crack detected.
- All parts with batch number for quality certified and traceability.
- YOKE Eye Hoist Hooks are proof tested to 2.5 times of 4:1 WLL, Hook Code AA and KK to 2 times of 5:1 WLL.
- YOKE Eye Hoist Hooks are Predrilled to accept a YOKE latch kits.
- YOKE Eye Hoist Hooks are supplied with certification.

Alloy Eye Hoist Hook

Item No.		Working Load Limit tonnes*	G100 Working Load Limit 4 : 1	Hook Feature Code	Dimensions (inch)								N.W. lbs
with latch	without latch				A	D	d	H	K	P	P1	T	
					5 : 1								
8-173-01	8-173/0-01	1	-	AA	0.91	0.87	0.39	0.75	3.27	1.02	0.87	0.59	0.7
8-173-015	8-173/0-015	1.5	1.4	BB	0.91	0.75	0.43	0.83	3.74	1.02	0.75	0.67	0.9
8-173-02	8-173/0-02	2	2.5	CC	1.14	0.79	0.51	1.02	4.17	1.10	0.79	0.83	1.5
8-173-03	8-173/0-03	3	4	DD	1.26	0.98	0.59	1.14	4.80	1.22	0.98	0.95	2.0
8-173-05	8-173/0-05	5	6.7	EE	1.57	1.22	0.71	1.46	5.87	1.45	1.22	1.22	4.4
8-173-07	8-173/0-07	7	10	FF	2.00	1.54	0.95	1.85	7.56	1.81	1.54	1.46	8.8
8-173-11	8-173/0-11	11	16	GG	2.44	2.24	1.10	2.28	9.13	2.40	2.24	1.89	15.4
8-173-15	8-173/0-15	15	19	HH	2.84	2.44	1.26	2.60	10.10	2.68	2.44	2.20	20.7
8-173-22	8-173/0-22	22	26.5	JJ	3.54	3.19	1.57	3.00	12.50	3.62	3.19	2.68	41.1
8-173-30	8-173/0-30	30	-	KK	3.54	3.27	1.77	3.66	14.10	3.50	3.27	2.99	68.9

- ★ Hook Code BB to JJ also categorized as G100 components.
- ★ Hook Code BB to JJ proof tested to 2.5 times of 4:1 WLL as G100 components.
- ★ Hook Code AA and KK proof tested to 2 times of 5:1 WLL.

Item No.		Working Load Limit tonnes*	G100 Working Load Limit 4 : 1	Hook Feature Code	Dimensions (mm)								N.W. kg
with latch	without latch				A	D	d	H	K	P	P1	T	
					5 : 1								
8-173-01	8-173/0-01	1	-	AA	23	22	10	19	83	26	22	15	0.3
8-173-015	8-173/0-015	1.5	1.4	BB	23	19	11	21	95	26	19	17	0.4
8-173-02	8-173/0-02	2	2.5	CC	29	20	13	26	106	28	20	21	0.7
8-173-03	8-173/0-03	3	4	DD	32	25	15	29	122	31	25	24	0.9
8-173-05	8-173/0-05	5	6.7	EE	40	31	18	37	149	37	31	31	2.0
8-173-07	8-173/0-07	7	10	FF	51	39	24	47	192	46	39	37	4.0
8-173-11	8-173/0-11	11	16	GG	62	57	28	58	232	61	57	48	7.0
8-173-15	8-173/0-15	15	19	HH	72	62	32	66	256	68	62	56	9.4
8-173-22	8-173/0-22	22	26.5	JJ	90	81	40	76	318	92	81	68	18.7
8-173-30	8-173/0-30	30	-	KK	90	83	45	93	357	89	83	76	31.3

- ★ Hook Code BB to JJ also categorized as G100 components.
- ★ Hook Code BB to JJ proof tested to 2.5 times of 4:1 WLL as G100 components.
- ★ Hook Code AA and KK proof tested to 2 times of 5:1 WLL.

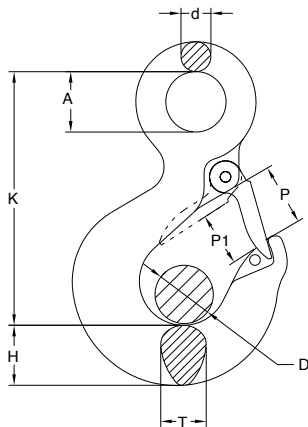

- YOKE carbon eye hoist hook are manufactured from the finest quality carbon steel.
- YOKE eye hoist hook are quenched and tempered.
- 20,000 cycle fatigue rate to 1.5 times working load limit.
- All eye hoist hooks are 100% magnaflux crack detected.
- All parts with batch number for quality certified and traceability.
- YOKE Eye Hoist Hooks are proof tested to 2 times the working load limit.
- YOKE Eye Hoist Hooks are Predrilled to accept a YOKE latch kits.
- YOKE Eye Hoist Hooks are supplied with certification.

Carbon Eye Hoist Hook

Item No.		Working Load Limit tonnes*	Hook Feature Code	Dimensions (inch)								N.W. lbs
with latch	without latch			A	D	d	H	K	P	P1	T	
8-193-0075	8-193/0-0075	0.75	AA	0.91	0.87	0.39	0.75	3.27	1.02	0.87	0.59	0.7
8-193-01	8-193/0-01	1	BB	0.91	0.75	0.43	0.83	3.74	1.02	0.75	0.67	0.9
8-193-015	8-193/0-015	1.5	CC	1.14	0.79	0.51	1.02	4.17	1.10	0.79	0.83	1.5
8-193-02	8-193/0-02	2	DD	1.26	0.98	0.59	1.14	4.80	1.22	0.98	0.95	2.0
8-193-03	8-193/0-03	3	EE	1.57	1.22	0.71	1.46	5.87	1.45	1.22	1.22	4.4
8-193-05	8-193/0-05	5	FF	2.00	1.54	0.95	1.85	7.56	1.81	1.54	1.46	8.8
8-193-075	8-193/0-075	7.5	GG	2.44	2.24	1.10	2.28	9.13	2.40	2.24	1.89	15.4
8-193-10	8-193/0-10	10	HH	2.84	2.44	1.26	2.60	10.10	2.68	2.44	2.20	19.8
8-193-15	8-193/0-15	15	JJ	3.54	3.19	1.57	3.00	12.50	3.62	3.19	2.68	40.7
8-193-20	8-193/0-20	20	KK	3.54	3.27	1.77	3.66	14.10	3.50	3.27	2.99	68.0

★ Minimum Ultimate Load is 5 times the Working Load Limit.
 Maximun Proof Load is 2 times the Working Load Limit.

Item No.		Working Load Limit tonnes*	Hook Feature Code	Dimensions (mm)								N.W. kg
with latch	without latch			A	D	d	H	K	P	P1	T	
8-193-0075	8-193/0-0075	0.75	AA	23	22	10	19	83	26	22	15	0.3
8-193-01	8-193/0-01	1	BB	23	19	11	21	95	26	19	17	0.4
8-193-015	8-193/0-015	1.5	CC	29	20	13	26	106	28	20	21	0.7
8-193-02	8-193/0-02	2	DD	32	25	15	29	122	31	25	24	0.9
8-193-03	8-193/0-03	3	EE	40	31	18	37	149	37	31	31	2.0
8-193-05	8-193/0-05	5	FF	51	39	24	47	192	46	39	37	4.0
8-193-075	8-193/0-075	7.5	GG	62	57	28	58	232	61	57	48	7.0
8-193-10	8-193/0-10	10	HH	72	62	32	66	256	68	62	56	9.0
8-193-15	8-193/0-15	15	JJ	90	81	40	76	318	92	81	68	18.5
8-193-20	8-193/0-20	20	KK	90	83	45	93	357	89	83	76	30.9

★ Minimum Ultimate Load is 5 times the Working Load Limit.
 Maximun Proof Load is 2 times the Working Load Limit.

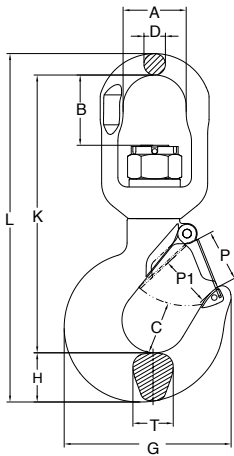

- YOKE alloy swivel hoist hook are manufactured from the finest quality alloy steel.
- YOKE swivel hoist hook are quenched and tempered.
- 20,000 cycle fatigue rated to 1.5 times of 4:1 WLL, Hook Code AA and KK to 1.5 times of 5:1 WLL.
- All swivel hoist hooks are 100% magnaflux crack detected.
- All parts with batch number for quality certified and traceability.
- YOKE Swivel Hoist Hooks are proof tested to 2.5 times of 4:1 WLL. Hook Code AA and KK to 2 times of 5:1 WLL.
- YOKE Swivel Hoist Hooks are Predrilled to accept a YOKE latch kits.

Alloy Swivel Hoist Hook

with Brass Washer

Item No.		Working Load Limit tonnes*	G100 Working Load Limit 4 : 1	Hook Feature Code	Dimensions (inch)										N.W. lbs	
with latch	without latch				A	B	C	D	G	H	K	L	P	P1		T
		5 : 1														
8-175-01	8-175/0-01	1	-	AA	1.26	0.91	0.97	0.45	3.06	0.75	4.86	6.06	1.02	0.87	0.63	1.3
8-175-015	8-175/0-015	1.5	1.4	BB	1.26	0.91	0.97	0.45	3.15	0.84	4.96	6.23	0.95	0.75	0.71	1.5
8-175-02	8-175/0-02	2	2.5	CC	1.42	1.14	1.03	0.49	3.66	1.00	5.63	7.15	1.06	0.79	0.88	2.2
8-175-03	8-175/0-03	3	4	DD	1.62	1.38	1.16	0.63	4.02	1.13	7.73	8.36	1.22	0.98	0.95	3.3
8-175-05	8-175/0-05	5	6.7	EE	1.83	1.73	1.53	0.83	5.14	1.41	8.32	10.58	1.42	1.22	1.22	7.0
8-175-07	8-175/0-07	7	10	FF	2.40	1.99	1.94	0.89	6.60	1.82	10.18	12.92	1.77	1.54	1.42	12.5
8-175-11	8-175/0-11	11	16	GG	2.92	3.25	2.46	0.99	7.72	2.28	12.84	16.11	2.40	2.24	1.89	20.9
8-175-15	8-175/0-15	15	19	HH	3.83	3.78	2.59	1.30	8.70	2.53	14.64	18.55	2.83	2.44	2.20	36.3
8-175-22	8-175/0-22	22	26.5	JJ	4.83	4.55	2.81	1.64	10.91	3.00	18.42	23.58	3.39	3.19	2.69	73.5
8-175-30	8-175/0-30	30	-	KK	4.83	4.24	3.44	1.64	13.90	3.60	19.67	25.63	3.50	3.27	3.00	101.0

★ Hook Code BB to JJ also categorized as G100 components.

★ Hook Code BB to JJ proof tested to 2.5 times of 4:1 WLL as G100 components.

★ Hook Code AA and KK proof tested to 2 times of 5:1 WLL.

Item No.		Working Load Limit tonnes*	G100 Working Load Limit 4 : 1	Hook Feature Code	Dimensions (mm)										N.W. kg	
with latch	without latch				A	B	C	D	G	H	K	L	P	P1		T
		5 : 1														
8-175-01	8-175/0-01	1	-	AA	32	23	25	12	78	19	123	154	26	22	16	0.6
8-175-015	8-175/0-015	1.5	1.4	BB	32	23	25	12	80	21	126	158	24	19	18	0.7
8-175-02	8-175/0-02	2	2.5	CC	36	29	26	13	91	25	143	181	27	20	22	1.0
8-175-03	8-175/0-03	3	4	DD	41	35	29	16	102	29	172	217	28	25	24	1.5
8-175-05	8-175/0-05	5	6.7	EE	46	44	38	21	130	36	211	269	36	31	31	3.2
8-175-07	8-175/0-07	7	10	FF	61	51	49	23	166	46	258	328	45	39	42	5.7
8-175-11	8-175/0-11	11	16	GG	74	82	62	25	196	58	326	409	61	57	48	9.5
8-175-15	8-175/0-15	15	19	HH	97	96	65	33	221	64	372	471	72	62	56	16.5
8-175-22	8-175/0-22	22	26.5	JJ	123	116	71	51	277	76	469	599	86	81	68	33.4
8-175-30	8-175/0-30	30	-	KK	123	116	87	51	353	93	503	651	89	83	76	45.9

★ Hook Code BB to JJ also categorized as G100 components.

★ Hook Code BB to JJ proof tested to 2.5 times of 4:1 WLL as G100 components.

★ Hook Code AA and KK proof tested to 2 times of 5:1 WLL.

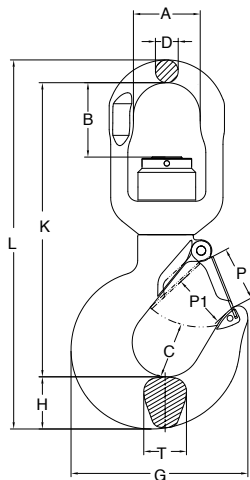

- YOKE alloy swivel hoist hook are manufactured from the finest quality alloy steel.
- YOKE swivel hoist hook are quenched and tempered.
- 20,000 cycle fatigue rated to 1.5 times of 4:1 WLL, Hook Code AA and KK to 1.5 times of 5:1 WLL.
- All swivel hoist hooks are 100% magnaflux crack detected.
- All parts with batch number for quality certified and traceability.
- YOKE Swivel Hoist Hooks are proof tested to 2.5 times of 4:1 WLL. Hook Code AA and KK to 2 times of 5:1 WLL.
- YOKE Swivel Hoist Hooks are Pre-drilled to accept a YOKE latch kits.

Alloy Swivel Bearing Hoist Hook

with Ball Bearing, which performs full swivel under load

Item No.		Working Load Limit	G100 Working Load Limit	Hook Feature Code	Dimensions (inch)										N.W. lbs		
with latch	without latch				tonnes*		A	B	C	D	G	H	K	L		P	P1
					5 : 1	4 : 1											
8-175N-01	8-175N/0-01	1	-	AA	1.26	0.91	0.97	0.45	3.06	0.75	4.86	6.06	1.02	0.87	0.63	1.3	
8-175N-015	8-175N/0-015	1.5	1.4	BB	1.26	0.91	0.97	0.45	3.15	0.84	4.96	6.23	0.95	0.75	0.71	1.5	
8-175N-02	8-175N/0-02	2	2.5	CC	1.42	1.14	1.03	0.49	3.66	1.00	5.63	7.15	1.06	0.79	0.88	2.2	
8-175N-03	8-175N/0-03	3	4	DD	1.62	1.38	1.16	0.63	4.02	1.13	7.73	8.36	1.22	0.98	0.95	3.5	
8-175N-05	8-175N/0-05	5	6.7	EE	1.83	1.73	1.53	0.83	5.14	1.41	8.32	10.58	1.42	1.22	1.22	7.3	
8-175N-07	8-175N/0-07	7	10	FF	2.40	1.99	1.94	0.89	6.60	1.82	10.18	12.92	1.77	1.54	1.42	12.3	
8-175N-11	8-175N/0-11	11	16	GG	2.92	3.25	2.46	0.99	7.72	2.28	12.84	16.11	2.40	2.24	1.89	20.9	
8-175N-15	8-175N/0-15	15	19	HH	3.83	3.78	2.59	1.30	8.70	2.53	14.64	18.55	2.83	2.44	2.20	35.2	
8-175N-22	8-175N/0-22	22	26.5	JJ	4.83	4.55	2.81	2.01	10.91	3.00	18.42	23.58	3.39	3.19	2.69	73.7	
8-175N-30	8-175N/0-30	30	-	KK	4.83	4.24	3.44	2.01	13.90	3.60	19.67	25.63	3.50	3.27	3.00	99.0	

- ★ Hook Code BB to JJ also categorized as G100 components.
- ★ Hook Code BB to JJ proof tested to 2.5 times of 4:1 WLL as G100 components.
- ★ Hook Code AA and KK proof tested to 2 times of 5:1 WLL.

Item No.		Working Load Limit	G100 Working Load Limit	Hook Feature Code	Dimensions (mm)										N.W. kg		
with latch	without latch				tonnes*		A	B	C	D	G	H	K	L		P	P1
					5 : 1	4 : 1											
8-175N-01	8-175N/0-01	1	-	AA	32	23	25	12	78	19	123	154	26	22	16	0.6	
8-175N-015	8-175N/0-015	1.5	1.4	BB	32	23	25	12	80	21	126	158	24	19	18	0.7	
8-175N-02	8-175N/0-02	2	2.5	CC	36	29	26	13	91	25	143	181	27	20	22	1.0	
8-175N-03	8-175N/0-03	3	4	DD	41	35	29	16	102	29	172	217	28	25	24	1.6	
8-175N-05	8-175N/0-05	5	6.7	EE	46	44	38	21	130	36	211	269	36	31	31	3.3	
8-175N-07	8-175N/0-07	7	10	FF	61	51	49	23	166	46	258	328	45	39	42	5.6	
8-175N-11	8-175N/0-11	11	16	GG	74	82	62	25	196	58	326	409	61	57	48	9.5	
8-175N-15	8-175N/0-15	15	19	HH	97	96	65	33	221	64	372	471	72	62	56	16.0	
8-175N-22	8-175N/0-22	22	26.5	JJ	123	116	71	51	277	76	469	599	86	81	68	33.5	
8-175N-30	8-175N/0-30	30	-	KK	123	116	87	51	353	93	503	651	89	83	76	45.0	

- ★ Hook Code BB to JJ also categorized as G100 components.
- ★ Hook Code BB to JJ proof tested to 2.5 times of 4:1 WLL as G100 components.
- ★ Hook Code AA and KK proof tested to 2 times of 5:1 WLL.

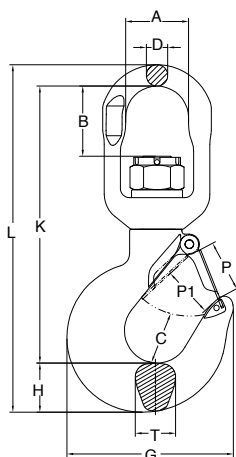

- YOKE carbon swivel hoist hook are manufactured from the finest quality carbon steel.
- YOKE swivel hoist hook are quenched and tempered.
- 20,000 cycle fatigue rate to 1.5 times working load limit.
- All swivel hoist hooks are 100% magnaflux crack detected.
- All parts with batch number for quality certified and traceability.
- YOKE Swivel Hoist Hooks are proof tested to 2 times the working load limit.
- YOKE Swivel Hoist Hooks are Pre-drilled to accept a YOKE latch kits.

Carbon Swivel Hoist Hook

with Brass Washer

Item No.		Working Load Limit tonnes*	Hook Feature Code	Dimensions (inch)											N.W. lbs
with latch	without latch			A	B	C	D	G	H	K	L	P	P1	T	
8-195-0075	8-195/0-0075	0.75	AA	1.26	0.91	0.97	0.45	3.06	0.75	4.86	6.06	1.02	0.87	0.63	1.3
8-195-01	8-195/0-01	1	BB	1.26	0.91	0.97	0.45	3.15	0.84	4.96	6.23	0.95	0.75	0.71	1.5
8-195-015	8-195/0-015	1.5	CC	1.42	1.14	1.03	0.49	3.66	1.00	5.63	7.15	1.06	0.79	0.88	2.2
8-195-02	8-195/0-02	2	DD	1.62	1.38	1.16	0.63	4.02	1.13	7.73	8.36	1.22	0.98	0.95	3.3
8-195-03	8-195/0-03	3	EE	1.83	1.73	1.53	0.83	5.14	1.41	8.32	10.58	1.42	1.22	1.22	7.0
8-195-05	8-195/0-05	5	FF	2.40	1.99	1.94	0.89	6.60	1.82	10.18	12.92	1.77	1.54	1.42	12.3
8-195-075	8-195/0-075	7.5	GG	2.92	3.25	2.46	0.99	7.72	2.28	12.84	16.11	2.40	2.24	1.89	20.9
8-195-10	8-195/0-10	10	HH	3.83	3.78	2.59	1.30	8.70	2.53	14.64	18.55	2.83	2.44	2.20	35.2
8-195-15	8-195/0-15	15	JJ	4.83	4.55	2.81	2.01	10.91	3.00	18.42	23.05	3.39	3.39	2.69	73.3

★ Minimum Ultimate Load is 5 times the Working Load Limit.
Maximum Proof Load is 2 times the Working Load Limit.

⚠ **WARNING INFORMATION:** This hook is a positioning device and is not intended to rotate under load. For swivel hooks designed to rotate under load, see pages 76 8-195N.

Item No.		Working Load Limit tonnes*	Hook Feature Code	Dimensions (mm)											N.W. kg
with latch	without latch			A	B	C	D	G	H	K	L	P	P1	T	
8-195-0075	8-195/0-0075	0.75	AA	32	23	25	12	78	19	123	154	22	26	16	0.6
8-195-01	8-195/0-01	1	BB	32	23	25	12	80	21	126	158	19	24	18	0.7
8-195-015	8-195/0-015	1.5	CC	36	29	26	13	91	25	143	181	20	27	22	1.0
8-195-02	8-195/0-02	2	DD	41	35	29	16	102	29	196	212	25	31	24	1.5
8-195-03	8-195/0-03	3	EE	46	44	38	21	130	36	211	269	31	36	31	3.2
8-195-05	8-195/0-05	5	FF	61	51	49	23	166	46	258	328	39	45	42	5.6
8-195-075	8-195/0-075	7.5	GG	74	82	62	25	196	58	326	409	57	61	48	9.5
8-195-10	8-195/0-10	10	HH	97	96	65	33	221	64	372	471	62	72	56	16.0
8-195-15	8-195/0-15	15	JJ	123	116	71	51	277	76	469	599	81	86	68	33.3

★ Minimum Ultimate Load is 5 times the Working Load Limit.
Maximum Proof Load is 2 times the Working Load Limit.

⚠ **WARNING INFORMATION:** This hook is a positioning device and is not intended to rotate under load. For swivel hooks designed to rotate under load, see pages 76 8-195N.

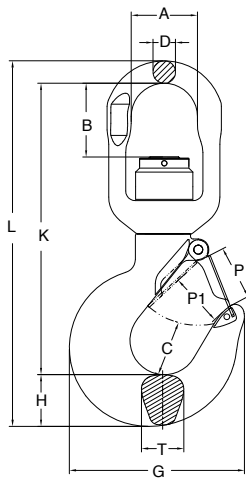

- YOKE carbon swivel hoist hook are manufactured from the finest quality carbon steel.
- YOKE swivel hoist hook are quenched and tempered.
- 20,000 cycle fatigue rate to 1.5 times working load limit.
- All swivel hoist hooks are 100% magnaflux crack detected.
- All parts with batch number for quality certified and traceability.
- YOKE Swivel Hoist Hooks are proof tested to 2 times the working load limit.
- YOKE Swivel Hoist Hooks are Pre-drilled to accept a YOKE latch kits.

Carbon Swivel Bearing Hoist Hook

with Ball Bearing, which performs full swivel under load

Item No.		Working Load Limit tonnes*	Hook Feature Code	Dimensions (inch)											N.W. lbs
with latch	without latch			A	B	C	D	G	H	K	L	P	P1	T	
8-195N-0075	8-195N/0-0075	0.75	AA	1.26	0.91	0.97	0.45	3.06	0.75	4.86	6.06	1.02	0.87	0.63	1.3
8-195N-01	8-195N/0-01	1	BB	1.26	0.91	0.97	0.45	3.15	0.84	4.96	6.23	0.95	0.75	0.71	1.5
8-195N-015	8-195N/0-015	1.5	CC	1.42	1.14	1.03	0.49	3.66	1.00	5.63	7.15	1.06	0.79	0.88	2.2
8-195N-02	8-195N/0-02	2	DD	1.62	1.38	1.16	0.63	4.02	1.13	7.73	8.36	1.22	0.98	0.95	3.5
8-195N-03	8-195N/0-03	3	EE	1.83	1.73	1.53	0.83	5.14	1.41	8.32	10.58	1.42	1.22	1.22	7.3
8-195N-05	8-195N/0-05	5	FF	2.40	1.99	1.94	0.89	6.60	1.82	10.18	12.92	1.77	1.54	1.42	12.3
8-195N-075	8-195N/0-075	7.5	GG	2.92	3.25	2.46	0.99	7.72	2.28	12.84	16.11	2.40	2.24	1.89	20.9
8-195N-10	8-195N/0-10	10	HH	3.83	3.78	2.59	1.30	8.70	2.53	14.64	18.55	2.83	2.44	2.20	35.2
8-195N-15	8-195N/0-15	15	JJ	4.83	4.55	2.81	2.01	10.91	3.00	18.42	23.58	3.39	3.39	2.69	73.0

★ Minimum Ultimate Load is 5 times the Working Load Limit.
 Maximum Proof Load is 2 times the Working Load Limit.

Item No.		Working Load Limit tonnes*	Hook Feature Code	Dimensions (mm)											N.W. kg
with latch	without latch			A	B	C	D	G	H	K	L	P	P1	T	
8-195N-0075	8-195N/0-0075	0.75	AA	32	23	25	12	78	19	123	154	26	22	16	0.6
8-195N-01	8-195N/0-01	1	BB	32	23	25	12	80	21	126	158	24	19	18	0.7
8-195N-015	8-195N/0-015	1.5	CC	36	29	26	13	91	25	143	181	27	20	22	1.0
8-195N-02	8-195N/0-02	2	DD	41	35	29	16	102	29	196	212	31	25	24	1.6
8-195N-03	8-195N/0-03	3	EE	46	44	38	21	130	36	211	269	36	31	31	3.3
8-195N-05	8-195N/0-05	5	FF	61	51	49	23	166	46	258	328	45	39	42	5.6
8-195N-075	8-195N/0-075	7.5	GG	74	82	62	25	196	58	326	409	61	57	48	9.5
8-195N-10	8-195N/0-10	10	HH	97	96	65	33	221	64	372	471	72	62	56	16.0
8-195N-15	8-195N/0-15	15	JJ	123	116	51	42	277	76	468	599	86	81	68	33.2

★ Minimum Ultimate Load is 5 times the Working Load Limit.
 Maximum Proof Load is 2 times the Working Load Limit.



- | | | | | | | | |
|---|---|---|---|---|---|---|---|
|  |  |  |  |  |  |  |  |
| 8-173 | 8-193 | 8-175 | 8-175N | 8-195 | 8-195N | 8-171 | 8-191 |
| Alloy
Eye Hoist Hook | Carbon
Eye Hoist Hook | Alloy
Swivel Hoist
Hook
brass washer | Alloy
Swivel Hoist
Hook
ball bearing | Carbon
Swivel Hoist
Hook
brass washer | Carbon
Swivel Hoist
Hook
ball bearing | Alloy
Shank Hoist Hook | Carbon
Shank Hoist Hook |

Hook Feature	Working Load Limit		Replacement
	tonnes*		
Code	Alloy	Carbon	Latch kits
AA	1	0.75	8-P801-AA
BB	1.5	1	8-P801-BB
CC	2	1.5	8-P801-CC
DD	3	2	8-P801-DD
EE	5	3	8-P801-EE
FF	7	5	8-P801-FF
GG	11	7.5	8-P801-GG
HH	15	10	8-P801-HH
JJ	22	15	8-P801-JJ
KK	30	20	8-P801-KK



Latch kits

YOKE[®]

Safety is our first priority[™]



8C-0283



*RFF[™] RingForged-Fabricated[™]
Heavy Duty Oilfield Sheave*

Designed and Manufactured
according to
API Spec 8C

A Grand Announcement of RFF™ RingForged-Fabricated™ Sheave by YOKE



YOKE Industrial Corporation of Taiwan are pleased to announce that following significant capital investment in Taichung manufacturing facility, that we have been awarded API 8C certification for the manufacture of large diameter heavy duty oilfield sheave. Steven Hong, Chairman of YOKE said " I am very proud of all our employees who have all worked extremely hard to achieve API 8C certification, whilst continuing to maintain our API Q1 facility, particularly the design, engineering and manufacturing people, On our 30 year anniversary this year in 2015, it is a significant milestone, being one of only a few global sheave manufacturers who have the technical and manufacturing capabilities to manufacture RFF™ RingForged-Fabricated™ Heavy Duty Oilfield Sheaves for the ever increasing demands of the energy industry."

YOKE continues to invest in advanced manufacturing techniques in order to meet our partners demands for high performance sheaves used in Drilling Blocks, Travelling Blocks, Tubing Blocks, Crown Blocks, Draw Works, Diverters and Motion Compensation sheaves both on Drill Ships, Land and Offshore Drilling Rigs and other energy related applications. YOKE's investment in capital equipment in 2014, a project to manufacture and supply large diameter RFF™ RingForged-Fabricated™ Heavy Duty Oilfield Sheaves by early 2015 came to its pinnacle this month, with the award of the API 8C certification.

YOKE's geographic manufacturing location close to many of the major drill ship and oil rig fabrication yards greatly reduces the lead time faced by many of its competitors. YOKE will work closely with its WDC and OEM partners to ensure that its range of API 8C sheaves are available in all the major energy related hubs around the globe.

This capital investment in larger diameter API 8C sheaves enhances YOKE's current range of YSB Snatch blocks and forged sheaves which already form a major section of their product offering of chain and wire rope fittings. YOKE continues to expand its range of material handling and lifting products in order to become the partner of choice in the energy industry.

YOKE also offers third party type approval on the range of YOKE RFF™ RingForged-Fabricated™ Heavy Duty Oilfield Sheaves, such as DNV, ABS, LRS and other major organizations.

The Features of YOKE

RFF™ RingForged-Fabricated™ Heavy Duty Oilfield Sheave

YOKE RFF™ RingForged-Fabricated™ sheave offers maximum strength with minimum weight, utilizing the advanced manufacturing techniques, it has developed for YOKE RFF™ RingForged-Fabricated™ sheave program for ultimate performance in the field.

Full penetration robot welding, stress relieving, groove profiling and hardening, balancing and final coating means that YOKE can offer a short lead time, for both of the shelf sheaves and customer designed, equipped with or without high performance bearings.

YOKE's design of RFF™ RingForged-Fabricated™ sheaves enables them to offer other benefits, such as increased rim wall thickness for large fleet angles, different levels of groove depth and hardness without having to sacrifice an increase in total sheave weight. YOKE Engineering can use modeling to develop the best mix of rim, web and hub to suit the application minimizing the weight but maintaining the strength, integrity and performance expected of a YOKE RFF™ RingForged-Fabricated™ sheave. This unique design offers a very competitive sheave and can enhance the lifetime performance.

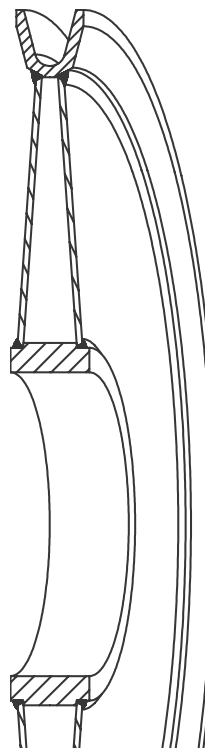

Domed Type



8C-0283

Groove angle Profile

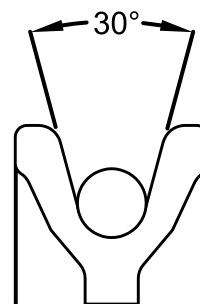

API STYLE

The Specification of YOKE RFF™ RingForged-Fabricated™ Sheave (Under Development)

Nominal Outside Diameter (inch)	Wire Line Size (inch)		
42	1-1/8	1-1/4	
48	1-1/8	1-1/4	
52	1-3/4		
60	1-3/8	1-1/2	1-5/8
72	1-3/4	2	2-1/4
78	1-3/4	2	2-1/4
90	2-1/2	2-3/4	

* YOKE RFF™ RingForged-Fabricated™ Sheave Production on Demand.

* For further detail in engineering services, please contact

YOKE RFF™ Engineered Product Group at rff_sheave@mail.yoke.net



**RFF™ RingForged-Fabricated™
Heavy Duty Domed Crown Oilfield Sheave**



Coupling Pin & Sleeve Set.



Item No.	Size		Working Load Limit tonnes*
	inch	mm	
8-P015-06	7/32	6	1.12
8-P015-07	1/4 - 5/16	7	2.0
8-P015-10	3/8	10	3.15
8-P015-13	1/2	13	5.3
8-P015-16	5/8	16	8.0
8-P015-20	3/4	18, 20	12.5
8-P015-22	7/8	22	15.0
8-P015-26	1	26	21.2
8-P015-32	1 1/4	32	31.5

G-100 Coupling Pin & Sleeve Set.

for X-015



Item No.	Size		Working Load Limit tonnes*
	inch	mm	
X-P015-06	7/32	6	1.4
X-P015-07	1/4 - 5/16	7	2.5
X-P015-10	3/8	10	4.0
X-P015-13	1/2	13	6.7
X-P015-16	5/8	16	10.0
X-P015-20	3/4	18,20	16.0
X-P015-22	7/8	22	19.0
X-P015-26	1	26	26.5
X-P015-32	1 1/4	32	40.0

Coupling Pin & C-Sleeve Set.

for 8-M015



Item No.	Size		Working Load Limit tonnes*
	inch	mm	
8-PM015-06	7/32	6	1.12
8-PM015-07	1/4 - 5/16	7	2.0
8-PM015-10	3/8	10	3.15
8-PM015-13	1/2	13	5.3
8-PM015-16	5/8	16	8.0
8-PM015-20	3/4	18, 20	12.5
8-PM015-22	7/8	22	15.0
8-PM015-26	1	26	21.2
8-PM015-32	1 1/4	32	31.5

G-100 Coupling Pin & C-Sleeve Set.

for X-M015



Item No.	Size		Working Load Limit tonnes*
	inch	mm	
X-PM015-06	7/32	6	1.4
X-PM015-07	1/4 - 5/16	7	2.5
X-PM015-10	3/8	10	4.0
X-PM015-13	1/2	13	6.7
X-PM015-16	5/8	16	10.0
X-PM015-20	3/4	18, 20	16.0
X-PM015-22	7/8	22	19.0
X-PM015-26	1	26	26.5
X-PM015-32	1-1/4	32	40.0

Load Pin Kits.

8-026, 8-018, 8-022, 8-042,
8-043, 8-059, 8-060, 8-061,
8-064, 8-066, 8-068, 8-069,
8-075, 8-091, 8-097

★ 8-P026-20 could not be used with 8-042-20 and 8-060-20



Item No.	Size		Working Load Limit tonnes*
	inch	mm	
8-P026-06	7/32	6	1.12
8-P026-07	1/4 - 5/16	7	2.0
8-P026-10	3/8	10	3.15
8-P026-13	1/2	13	5.3
8-P026-16	5/8	16	8.0
8-P026-20	3/4	18, 20	12.5
8-P026-22	7/8	22	15.0

G-100 Load Pin Kits

for X-026, X-042, X-043, X-046



Item No.	Size		Working Load Limit tonnes*
	inch	mm	
X-P026-06	7/32	6	1.4
X-P026-07	1/4 - 5/16	7	1.5
X-P026-10	3/8	10	4.0
X-P026-13	1/2	13	6.7
X-P026-16	5/8	16	10.0
X-P026-20	3/4	18, 20	16.0
X-P026-22	7/8	22	19.0

Latch Kits.

for 8-044, 8-043, X-044,
X-043



Item No.	Size	
	inch	mm
8-P044-06	7/32	6
8-P044-07	1/4 - 5/16	7
8-P044-10	3/8	10
8-P044-13	1/2	13
8-P044-16	5/8	16.0
8-P044-20	3/4	18, 20
8-P044-22	7/8	22
8-P044-26	1	26
8-P044-32	1 1/4	32

Latch Kits.

for 8-049



Item No.	Size	
	inch	mm
8-P049-06	7/32	6
8-P049-07	1/4 - 5/16	7
8-P049-10	3/8	10
8-P049-13	1/2	13
8-P049-16	5/8	16.0
8-P049-20	3/4	18, 20

Latch Kits.

for 8-074



Item No.	Size	
	inch	mm
8-P074-09/13	3/8	9, 13
	9/16	14, 16

Latch Kits.

for 8-921, 8-931



Item No.	Size
	tonnes*
8-P921-03	3
8-P921-05	5
8-P921-07	7
8-P921-11	11
8-P921-15	15
8-P921-22	22
8-P921-30	30

Load Pin Kits.

for 8-072



Item No.	Size		Working Load Limit tonnes*
	inch	mm	
8-P072-07	1/4 - 5/16	7	2.0
8-P072-10	3/8	10	3.15
8-P072-13	1/2	13	5.3
8-P072-16	5/8	16	8.0

Latch Kits.

for 8-081



Item No.	Size
	tonnes*
8-P081-01	1
8-P081-02	2
8-P081-03	3
8-P081-04	4
8-P081-05	5
8-P081-08	8
8-P081-10	10
8-P081-15	15

Trigger Kits For Grip Self Locking Hooks

For X-950, X-951, X-952N



Item No.	Size		Working Load Limit tonnes*
	inch	mm	
8-P950-10	3/8	10	4.0
8-P950-13	1/2	13	6.7
8-P950-16	5/8	16	10.0
8-P950-20	3/4	20,22	16.0

Trigger Kits for G80 and G100 Self Locking Hooks



Item No.	Size	
	inch	mm
8-P025-06	7/32	6
8-P025-07	1/4-5/16	7
8-P025-10	3/8	10
8-P025-13	1/2	13
8-P025-16	5/8	16
8-P025-20	3/4	18,20
8-P025-22	7/8	22
8-P025-26	1	26
8-P025-28	1-1/8	28

**For G100 size 20mm: X-P025-20

New Trigger Kits for Self Locking Hooks size 20mm, 26mm, and 28mm after design change



G80 size 20mm		
Item No.	Size	
	inch	mm
8-P025T-20	3/4	18,20
G80 and G100 size 26mm		
Item No.	Size	
	inch	mm
8-P025T-26	1	26
G80 size 28mm		
Item No.	Size	
	inch	mm
8-P025T-28	1-1/8	28

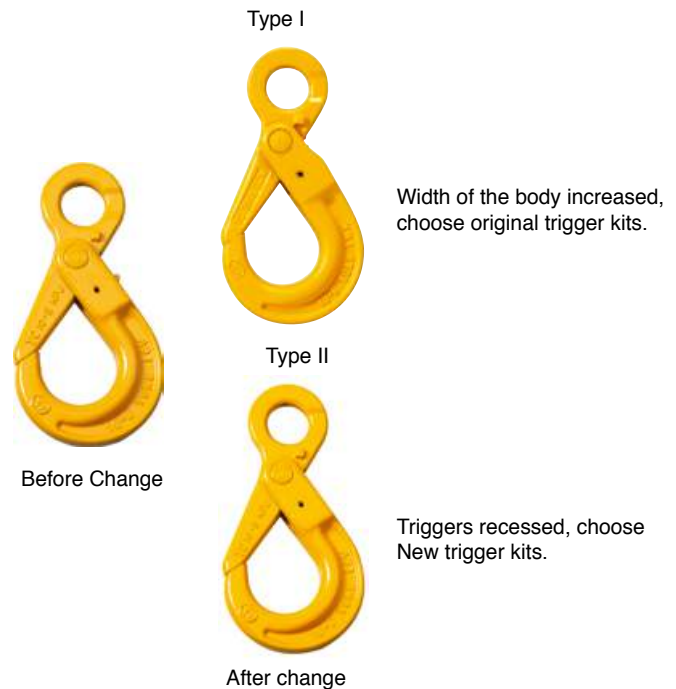

INDEX

By Item. Number

Item No.	Page	Item No.	Page	Item No.	Page	Item No.	Page
8-003	124	8-078	136	8-307	250	8-9400	156
8-003F	124	8-078	139	8-308	251	8-941FT	176
8-015	126	8-080	141	8-306	249	8-951	177
8-016	143	8-088	149	8-307	250	8-951DH	178
8-018	126	8-089	141	8-308	251	8-M015	126
8-019	140	8-091	132	8-500	203	8-S291	30
8-020	146	8-092	140	8-501	187	8-S292	32
8-020N	146	8-093	141	8-502	188	903Y	222
8-021	146	8-097	131	8-503	189	8-029	143
8-021N	146	8-121	152	8-504	204	DA-003F	165
8-022	129	8-122	152	8-512	205	DA-007F	166
8-023	148	8-123	153	8-514	206	DA-025	170
8-024	128	8-124	153	8-515	207	DA-027N	169
8-025	127	8-125	153	8-521	209	DA-271	48
8-026	127	8-126	154	8-522	210	DA-271	171
8-027	128	8-127	155	8-523	209	DA-272	50
8-027N	128	8-128	154	8-531	211	DA-272	173
8-028	145	8-129	155	8-532	211	DA-808	168
8-030	144	8-130	154	8-541	190	DA-838	167
8-031	144	8-131	155	8-542	191	X-001	83
8-036	144	8-132	152	8-543	192	X-002F	88
8-039	130	8-171.SC	253	8-551	193	X-003	90
8-041	133	8-173	104	8-552	194	X-006F	89
8-042	133	8-173	255	8-553	195	X-007	85
8-043/S	131	8-175	105	8-561	196	X-015	94
8-044/S	130	8-175	257	8-562	197	X-016	117
8-045	140	8-175N	258	8-563	198	X-019	101
8-047	130	8-191.SC	254	8-571	199	X-025	97
8-048	138	8-193	256	8-572	200	X-026	98
8-049	130	8-194	175	8-573	201	X-027	99
8-049N	129	8-195	259	8-591	202	X-027N	100
8-050	150	8-195N	260	8-730	213	X-028	119
8-051	149	8-203	56	8-731	214	X-032	118
8-052	149	8-204	58	8-732	215	X-041	109
8-053	150	8-211	14	8-733	216	X-042	110
8-054	151	8-211	18	8-734	217	X-043	103
8-055	150	8-212	16	8-735	218	X-044	102
8-056	125	8-231	20	8-739	219	X-046	108
8-0573	68	8-231	24	8-751	232	X-047	107
8-058	64	8-232	22	8-752	234	X-059	120
8-059	125	8-241	56	8-753	236	X-061	111
8-060	134	8-242	58	8-754	238	X-066	121
8-061	133	8-251	40	8-755	240	X-078	112
8-062	134	8-252	42	8-762	242	X-950	114
8-063	139	8-271	34	8-804	230	X-951	115
8-064	134	8-272	36	8-805	230	X-952N	116
8-065	135	8-082	71	8-807	226	X-A04	91
8-066	131	8-082	70	8-807	226	X-A05	92
8-067	137	8-291K	26	8-808	225	X-A06	93
8-068	137	8-292K	28	8-809	229	X-M015	95
8-069	137	8-301	245	8-834	231	901	223
8-071	139	8-303	246	8-835	231	902	221
8-072	136	8-304	247	8-837	228	903	221
8-073	138	8-305	248	8-838	227	9041	222
8-074	138	8-306	249	8-911	180	9042	222
8-075	132			8-921	181	8-2511	44
8-077	135			8-931	182	8-2521	46

Code & Number

Code	Page	Code	Item No.	Code	Item No.	Code	Item No.
BSI	158	BSI	8-088	BSI	8-088	YE	8-027
BST	160	YEN	137	BST	8-054	YEA	8-024
DA	134	YF	141	DA	8-056	YEN	8-027N
DAA	66	YG	134	DAA	8-057	YF	8-091
DAB	59	YH	142	DAB	8-058	YG	8-059
DC	153	YK	142	DC	8-036	YH	8-041
EA	159	YL	157	EA	8-050	YK	8-042
EB	159	YM	139	EB	8-055	YL	8-023
EC	158	YN	139	EC	8-051	YM	8-043/S
ECO	158	YO	135	ECO	8-052	YN	8-047
EF	144	YP	139	EF	8-077	YO	8-018
EH	155	YR	140	EH	8-020	YP	8-044/S
EHN	155	YSW	138	EHN	8-020N	YR	8-066
EHY	155	YSWN	138	EHY	8-021	YSW	8-049
EHYN	155	YSWX	147	EHYN	8-021N	YSWN	8-049N
EL	139	YT	141	EL	8-039	YSWX	8-048
EM	150	YW	159	EM	8-089	YT	8-075
EX	145	YX	64	EX	8-072	YW	8-053
FA	150			FA	8-093	YX	8-081
FE	140			FE	8-097		
FG	149			FG	8-092		
FH	149			FH	8-045		
FM	153			FM	8-031		
FN	153			FN	8-030		
FT	152			FT	8-029		
KA	146			KA	8-067		
KB	146			KB	8-068		
KC	143			KC	8-060		
KCK	142			KCK	8-061		
KD	143			KD	8-062		
KE	148			KE	8-063		
KF	147			KF	8-074		
KK	148			KK	8-071		
KL	147			KL	8-073		
KP	138			KP	8-022		
KR	143			KR	8-064		
KS	148			KS	8-076		
KT	144			KT	8-065		
KU	146			KU	8-069		
MF	133			MF	8-003		
MFF	133			MFF	8-003F		
YA	135			YA	8-015		
YC	136			YC	8-025		
YD	136			YD	8-026		
YE	137			YE	8-027		
YEA	137			YEA	8-024		



Safety is our first priority™

An ISO 9001 Registered Company

YOKE products distributed by:

YOKE INDUSTRIAL CORP.

#39, 33rd Road,
Taichung Industrial Park,
Taichung 407,
TAIWAN

Tel:+886-4-2350-8088

Fax:+886-4-2350-1001

E-mail: info@mail.yoke.net



www.yoke.net